

EN **Assembly instructions**

DE **Montageanleitung**

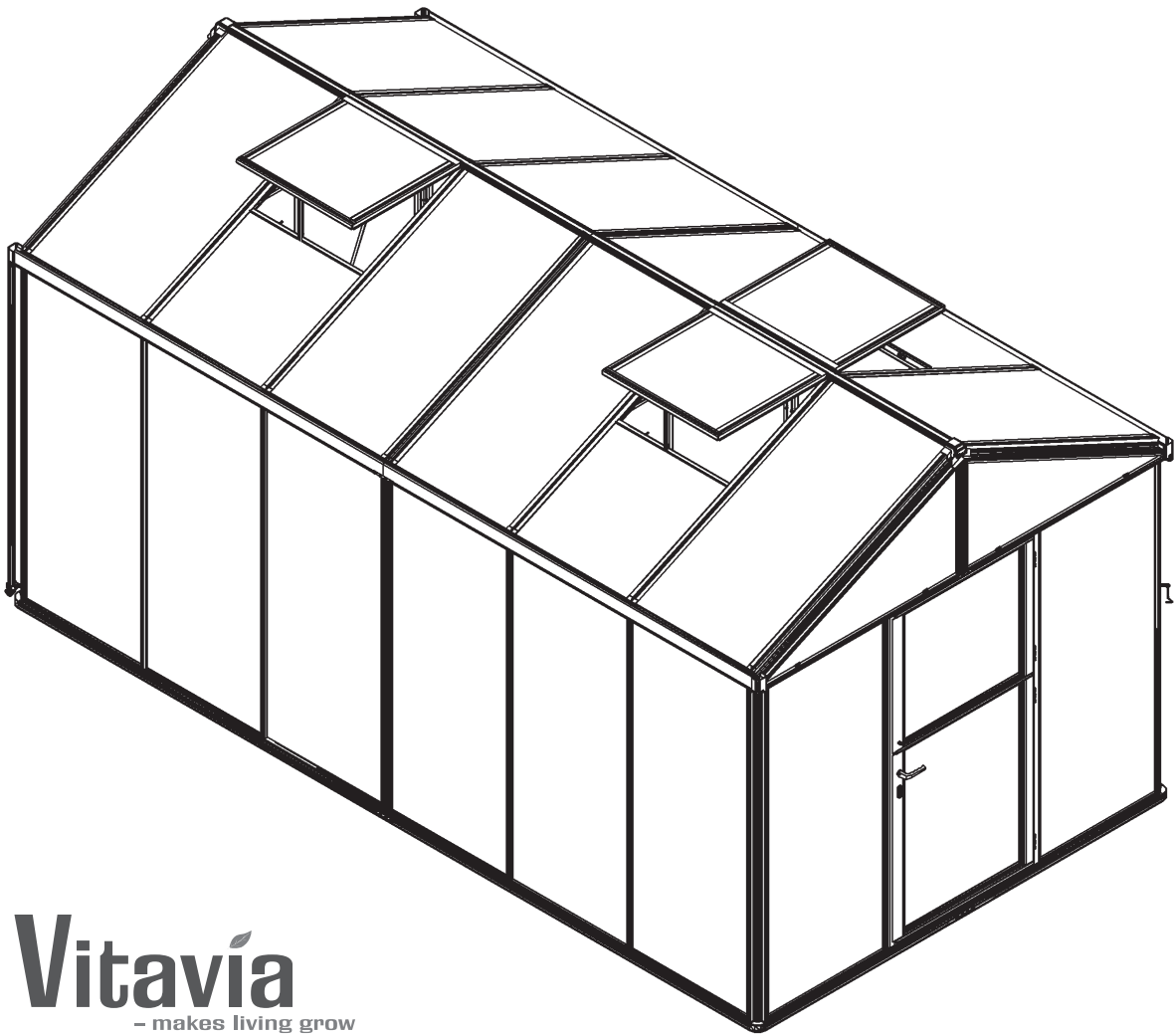

Vitavia
- makes living grow

ZEUS 2
8100, 10000, 11900, 13800, 15700

Dear Customer,

Thank you for choosing our quality product.
We feel confident that it will bring you a lot of pleasure.



Please read these instructions carefully and completely before assembling your greenhouse.

• Contents / Symbols	S.2
• Recommendations	S.3
• Safety Notice	S.4
• Maintenance	S.5
• Part List Summary	S.6
• Part list Pack 1-1	S. 7-9
• Part list Pack 1-2	S. 10-18
• Part list Pack 2	S. 19-23
• Part list Pack 3	S. 24-28
• Part list Pack 4	S. 29-33
• Part list Pack 5 - Roof Vent	S. 34-35
• Foundation	S. 36-37
Assembly	
• Step 1 Sill Bars / Corner Posts	S. 38-39
• Step 2 Middle Bars / Eave Angles	S. 40-41
• Step 3 Middle Bars	S. 42-43
• Step 4 Roof	S. 44-47
• Step 5 Roof Vents	S. 48-49
• Step 6 Doors	S. 50-53
• Step 7 Glazing	S. 54-63
• Step 8 Finishing	S. 64-65
• Step 9 Down pipes	S. 66-67



Diagrams in a single frame show the view from inside the greenhouse.

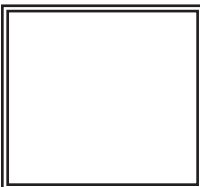

Diagrams in a double frame show the view from outside the greenhouse.



Important Tip, please take note:



Sharp edges and corners can cause injury. Always wear protective glasses, gloves, shoes and headgear when handling the aluminium profiles, glass and polycarbonate sheets. Broken glass is a safety hazard – always clear up immediately and dispose of with care.

Note:

The product you have purchased is intended **only** for the growing of plants and should **only** be used for this purpose. When used for other purposes we will take no responsibility.

Site Selection

Always try to select a sunny location, sheltered from the wind as much as possible. The site selection is important to ensure best results when cultivating your plants and for the safety of your house.

Before you begin:

Before assembling your new greenhouse, please check that all parts in the provided lists are included. Please take each bundle out of the packaging in order to identify the parts better.

The part lists are sorted according to the carton in which they are delivered.

It is important that the opened bundles do not get mixed with one another.

If something is missing please contact your retailer.

If you find that a part does not fit as shown **do not** make any changes to the part. Please contact your retailer, who will guide you to the relevant customer service partner.

Our policy is one of continuous improvement and we reserve the right to change the specifications without prior notice. This can lead to small differences between your product and that shown in this manual.

The following tools are required:

- **Screw drivers (Normal and Crosshead PH2)**
- **Rubber hammer**
- **2 x 1.8m ladders**
- **10mm combination spanner**
- **Spirit level**
- **Craft knife**
- **Accu-drill with adjustable torque**
- **Ø 20 drill**

Safety Notice

- **Sharp edges and corners can cause injury. Always wear protective glasses, gloves, shoes and headgear when handling the aluminium profiles, glass and polycarbonate sheets. Broken glass is a safety hazard – always clear up immediately and dispose of with care.**
- **It is recommended that this greenhouse is assembled by two to three people.**
- **Important! Danger of crushing during assembly.**
- **The greenhouse should not be assembled during strong wind or storm conditions.**
- **The greenhouse must always be anchored.**
- **Please check the tightness of all nuts and bolts 2 weeks after completing the assembly.**
- **In the event of high wind conditions, close the doors and all vents.**
- **In the event of heavy snowfall, clear the roof of the building or take suitable measures to support the roof. Heat the building in winter.**



Please read these instructions carefully and completely before assembling your greenhouse.

The greenhouse should be thoroughly washed with a gentle detergent occasionally. The glass can be cleaned with glass cleaner. Please check that the cleaning agents used do not react aggressively with aluminium or plastic.

If you are unsure if the cleaning agent is appropriate please test it on a small area out of direct sunlight.



Note:

For the complete protection of your new greenhouse, we advise you to include it in your house insurance. Please take note of possible building rules relating to the positioning of greenhouses.

Please stick the included greenhouse model label onto the door bar after successfully assembling this product. This information is important in the event that replacement parts are later required.

Please keep these Assembly Instructions in a safe place, for future reference!



Note:

Please follow exactly the instructions and tips provided in this instruction manual to avoid any difficulties. Should you find a potential failure in this manual, or find a point not clearly explained, please contact your retailer.

We appreciate your suggestions and support.

A full range of greenhouse accessories, to help you make the most of this product, is available from your stockist. Please make yourself aware of these.

Part List



Before beginning the assembly of your new greenhouse, please check that all parts in the following part lists are included. Please take each bundle out of the packaging to identify the parts more easily.

It is important that the opened bundles do not get mixed with one another.

If something is missing please contact your retailer.



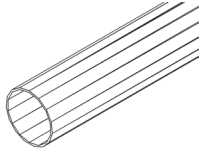
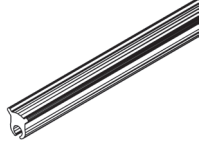

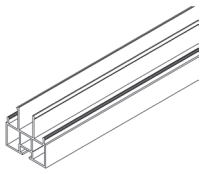
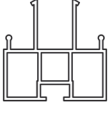
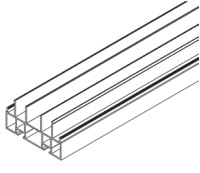
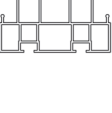
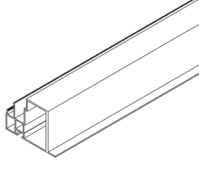
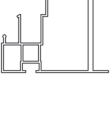
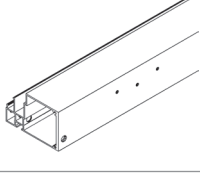
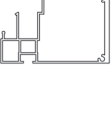
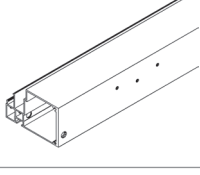
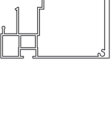
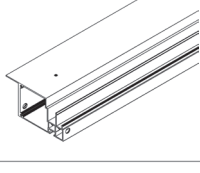
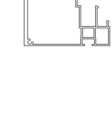
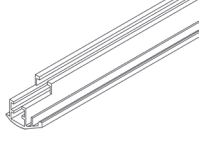
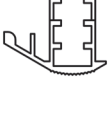





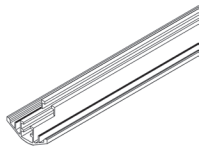

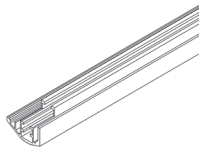
Model	Pack 1-1	Pack 1-2	Pack 2	Pack 3	Pack 4	Pack 5
8100	1	1	2			
10000	1	1	1	1		
11900	1	1		2		1
13800	1	1		1	1	1
15700	1	1			2	1

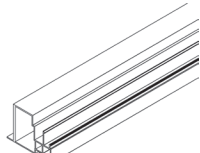

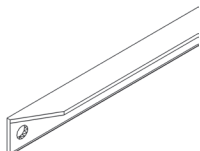
Part List

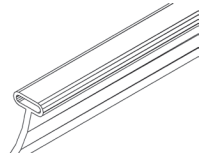
Pack 1-1					Required Quantity / Model					Profile
Item No.	Part	Section Ref.	Size mm	Quantity in Carton	8100	10000	11900	13800	15700	
1415		9	1750	2	2	2	2	2	2	
6090		7b 7c	56000	1	77000	85500	94000	103000	112000	
7005		3	1775	2	6	8	10	12	14	
7006		2	1775	3	3	3	3	3	3	
7014		2	1775	1	1	1	1	1	1	
7015		6b	1000	1	1	1	1	1	1	
7017		6a	717	1	1	1	1	1	1	
7018		6a	717	1	1	1	1	1	1	
7030		7b	1793	2	2	2	2	2	2	

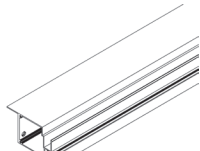
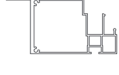
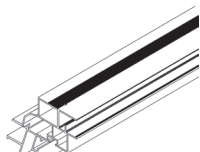
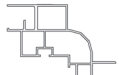
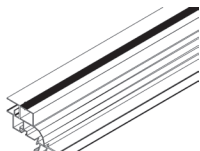
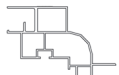
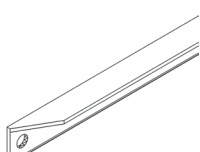
ZEUS 2

Part List

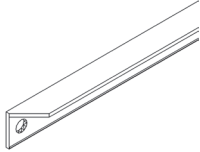
Pack 1-1					Required Quantity / Model					
Item No.	Part	Section Ref.	Size mm	Quantity in Carton	8100	10000	11900	13800	15700	Profile
7032		7b	1793	2	6	8	10	12	14	
7033		7b	1793	14	14	14	14	14	14	
7045		2	1775	1	1	1	1	1	1	
7069		3	1924	4	4	4	4	4	4	
7083		6a 6b	900	2	2	2	2	2	2	
7216		6b	1000	1	1	1	1	1	1	
7237		4a	1362	2	2	2	2	2	2	
7238		4a	1362	2	2	2	2	2	2	
7269		3	1926	4	4	4	4	4	4	



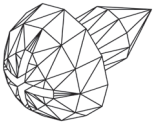

Pack 1-1					Required Quantity / Model					
Item No.	Part	Section Ref.	Size mm	Quantity in Carton	8100	10000	11900	13800	15700	Profile
7295		4a	1531.5	4	4	4	4	4	4	

Part List

Part List

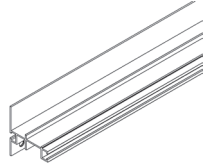
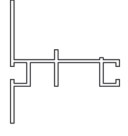
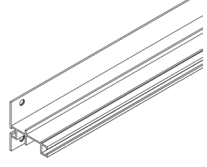
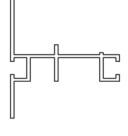
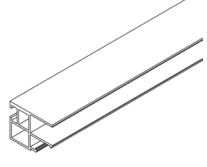
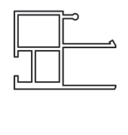
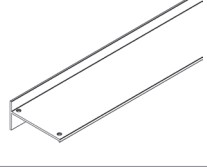

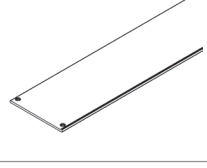
Pack 1-2					Required Quantity / Model					Profile
Item No.	Part	Section Ref.	Size mm	Quantity in Carton	8100	10000	11900	13800	15700	
1002		9	M6	2	2	2	2	2	2	
1006		4b 5 6a 6b 9	3.5x6	22	32	32	38	38	38	
1402		9	36	2	2	2	2	2	2	
1403		9	20	2	2	2	2	2	2	
1405		9	15	2	2	2	2	2	2	
1409		9	20	2	2	2	2	2	2	
1412		9	M6x22	2	2	2	2	2	2	
7003	1	1230	2	2	2	2	2	2		
7004		1	1230	2	2	2	2	2	2	

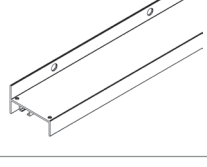
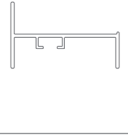
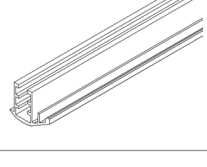
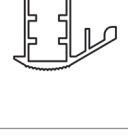
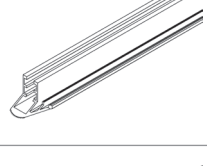
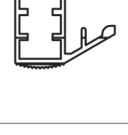
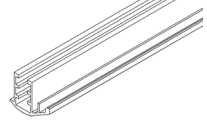
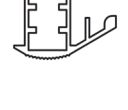
Part List

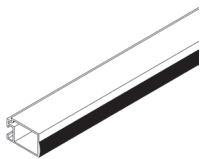
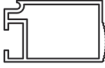
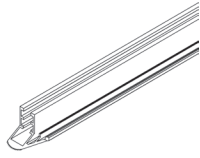
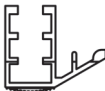
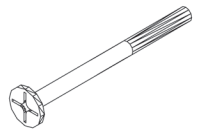
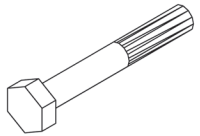
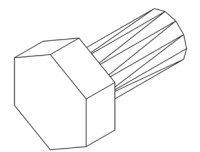
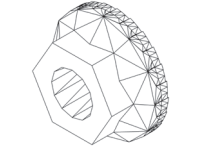

Pack 1-2					Required Quantity / Model					Profile
Item No.	Part	Section Ref.	Size mm	Quantity in Carton	8100	10000	11900	13800	15700	
7010		2	1229.5	2	2	2	2	2	2	
7011		2	1229.5	2	2	2	2	2	2	
7022		6a 6b	708	4	4	4	4	4	4	
7023		6b	850	1	1	1	1	1	1	
7024		6a	850	1	1	1	1	1	1	
7025		6a 6b	850	2	2	2	2	2	2	
7031		7c	996	2	2	2	2	2	2	
7034		7b 7c	733	8	16	18	20	22	24	
7035		7c	713	2	2	2	2	2	2	

ZEUS 2

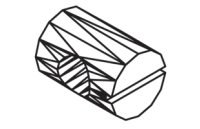
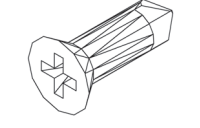
Part List

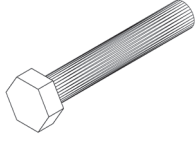
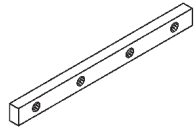
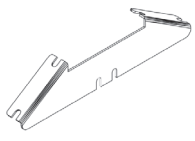
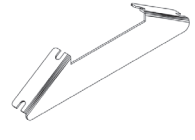
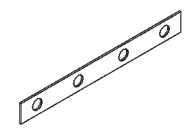
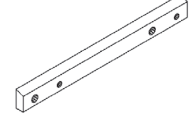
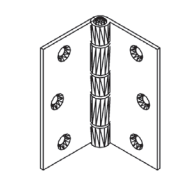
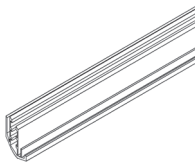
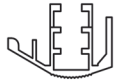
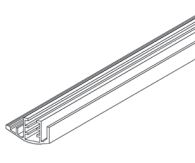

Pack 1-2					Required Quantity / Model					
Item No.	Part	Section Ref.	Size mm	Quantity in Carton	8100	10000	11900	13800	15700	Profile
7036		7b	922	1	1	1	1	1	1	
7044		7b	443	2	2	2	2	2	2	
7048		4b	M6x80	2	0	1	2	2	2	
7050		7b	M6x42	92	126	138	150	162	174	
7052		1, 2 3, 4 5, 6 7a	M6x12	104	154	176	202	224	246	
7053		1, 2 3, 4 5, 6 7, 8	M6x4	223	307	341	379	413	447	
7054		4b 6	M6x100	8	12	12	14	14	14	
7055		4b 6	M6x10 x14	8	12	12	14	14	14	
7056		8	3.9x13	4	4	4	4	4	4	

Part List

Pack 1-2					Required Quantity / Model					Profile
Item No.	Part	Section Ref.	Size mm	Quantity in Carton	8100	10000	11900	13800	15700	
7058		7c	M6x38	22	22	22	22	22	22	
7061		1 2 4a 7a	117	9	15	15	15	15	15	
7062		4	235	4	6	7	8	9	10	
7063		3	255	4	8	10	12	14	16	
7064		1 2 4a 7a	117	5	11	11	11	11	11	
7065		4a	140	2	2	2	2	2	2	
7066		6	75	4	4	4	4	4	4	
7074		7b	1369	2	2	2	2	2	2	
7075		7b	1369	2	2	2	2	2	2	

ZEUS 2

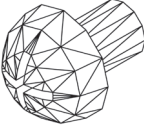
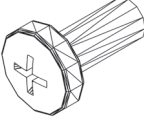
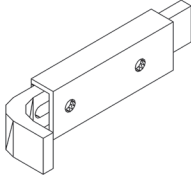
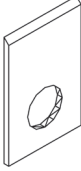
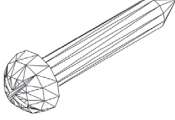
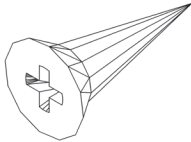
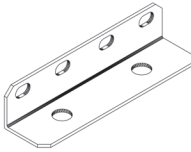
Part List

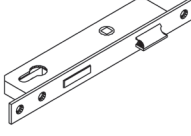
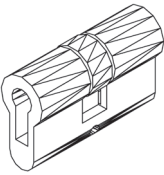





Pack 1-2					Required Quantity / Model					Profile
Item No.	Part	Section Ref.	Size mm	Quantity in Carton	8100	10000	11900	13800	15700	
7080		1 2 4a 7a	M6x8	36	60	60	60	60	60	
7081		4a	M5x13	4	4	4	4	4	4	
7085		6a	95	1	1	1	1	1	1	
7086		6b	23	1	1	1	1	1	1	
7087		6a	5x30	2	2	2	2	2	2	
7088		6 8	3.9x13	32	30	30	30	30	30	
7095		1	117	4	4	4	4	4	4	
7100		6b	244	1	1	1	1	1	1	
7101		6b	62	1	1	1	1	1	1	

Part List

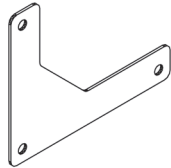
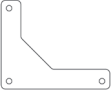
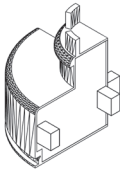
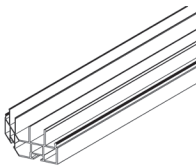
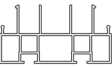
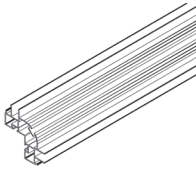
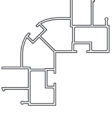
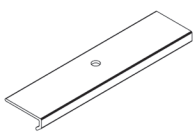

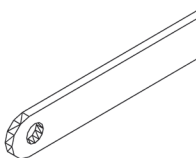

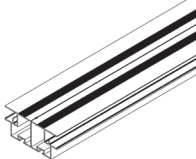

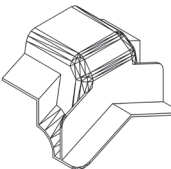
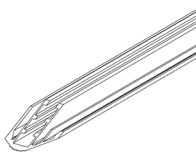
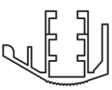
Pack 1-2					Required Quantity / Model					
Item No.	Part	Section Ref.	Size mm	Quantity in Carton	8100	10000	11900	13800	15700	Profile
7102		6b	M5x35	1	1	1	1	1	1	
7103		6b	65	2	2	2	2	2	2	
7104		6b	125	2	2	2	2	2	2	
7106		6b	Ø 27	2	2	2	2	2	2	
7107		6b	100	1	1	1	1	1	1	
7108		6b	4.7x8	2	2	2	2	2	2	
7111		8	35	1	1	1	1	1	1	
7112		8	8	1	1	1	1	1	1	
7113		8	100	1	1	1	1	1	1	

ZEUS 2

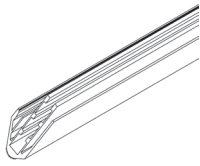
Part List

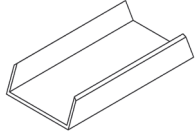

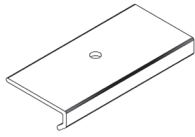

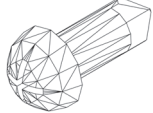
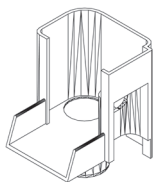
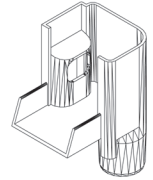
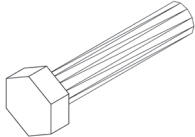
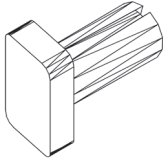
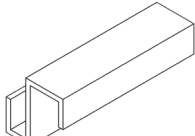
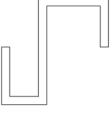

Pack 1-2					Required Quantity / Model					Profile
Item No.	Part	Section Ref.	Size mm	Quantity in Carton	8100	10000	11900	13800	15700	
7114		6	138	4	4	4	4	4	4	
7200		1	62	4	4	4	4	4	4	
7219		3	569.5	2	2	2	2	2	2	
7236		1	1775	4	4	4	4	4	4	
7240		7a	88	2	2	2	2	2	2	
7249		4b	1251	1	3	4	5	6	7	
7256		4a	1356	2	2	2	2	2	2	
7266		8	91	2	2	2	2	2	2	
7276		7b	582	2	2	2	2	2	2	

Part List

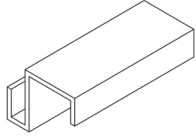

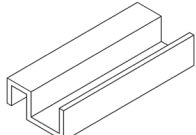
Pack 1-2					Required Quantity / Model					
Item No.	Part	Section Ref.	Size mm	Quantity in Carton	8100	10000	11900	13800	15700	Profile
7277		7b	582	2	2	2	2	2	2	
7292		7a	100	2	2	2	2	2	2	
7342		7a	45	4	4	4	4	4	4	
7349		7a 8	3.9x10	6	38	46	56	64	72	
7370		8	71	2	2	2	2	2	2	
7371		8	71	2	2	2	2	2	2	
7390		7b	M6x30	4	4	4	4	4	4	
7399		8	M6x12	1	1	1	1	1	1	
7406		7b	30	6	14	16	18	20	22	

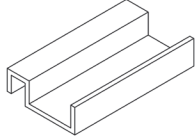
ZEUS 2

Part List



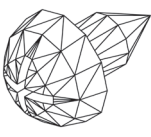
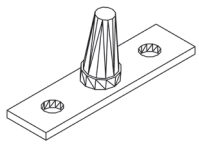
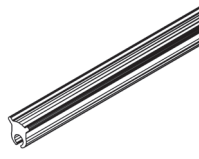

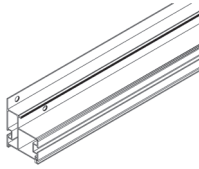
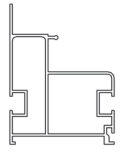
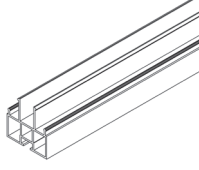
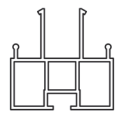
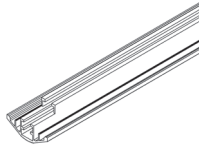
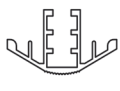
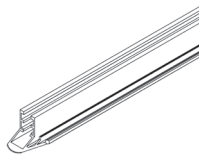
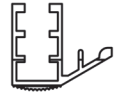
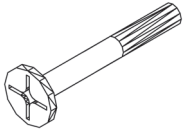
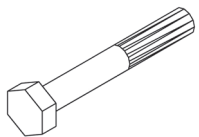
Pack 1-2					Required Quantity / Model					
Item No.	Part	Section Ref.	Size mm	Quantity in Carton	8100	10000	11900	13800	15700	Profile
7407		7b	30	6	14	16	18	20	22	
7408		7b	30	8	8	8	8	8	8	
7409		7b	30	8	8	8	8	8	8	

Part List



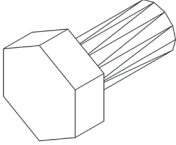

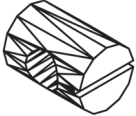
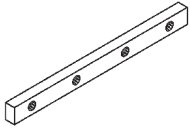
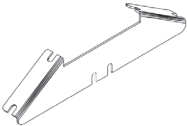

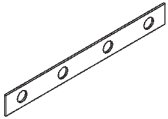
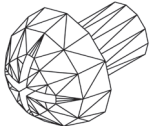

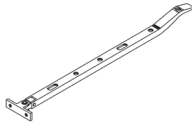
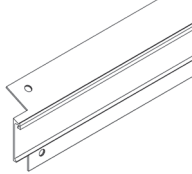
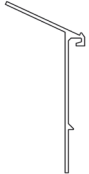
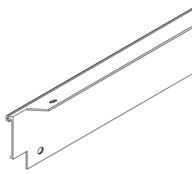
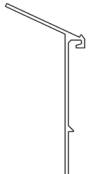
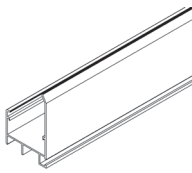
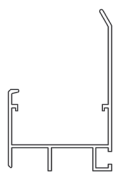
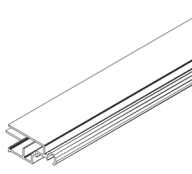

Pack 2					Required Quantity / Model					
Item No.	Part	Section Ref.	Size mm	Quantity in Carton	8100	10000	11900	13800	15700	Profile
1006		4b 5 6a 6b 9	3.5x6	6	32	32	38	38	38	
6056		4b	46	2	4	4	6	6	6	
6090		7b 7c	10500	1	77000	85500	94000	103000	112000	
7001		1	1520	2	4	2	-	-	-	
7005		3	1775	2	6	8	10	12	14	
7032		7b	1793	2	6	8	10	12	14	
7034		7b 7c	733	4	16	18	20	22	24	
7047		4b	M6x48	1	2	4	4	6	8	
7050		7b	M6x42	19	126	138	150	162	174	

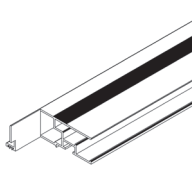
ZEUS 2

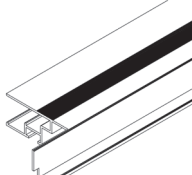
Part List

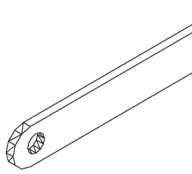

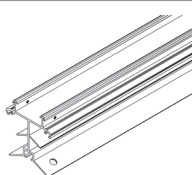



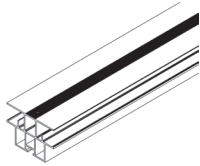

Pack 2					Required Quantity / Model					Profile
Item No.	Part	Section Ref.	Size mm	Quantity in Carton	8100	10000	11900	13800	15700	
7052		1, 2 3, 4 5, 6 7a	M6x12	30	154	176	202	224	246	
7053		1, 2 3, 4 5, 6 7, 8	M6x4	49	307	341	379	413	447	
7054		4b 6	M6x100	2	12	12	14	14	14	
7055		4b 6	M6x10 x14	2	12	12	14	14	14	
7061		1 2 4a 7a	117	3	15	15	15	15	15	
7062		4	235	1	6	7	8	9	10	
7063		3	255	2	8	10	12	14	16	
7064		1 2 4a 7a	117	3	11	11	11	11	11	
7080		1 2 4a 7a	M6x8	12	60	60	60	60	60	

Part List

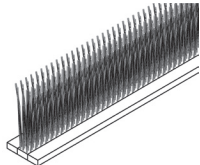

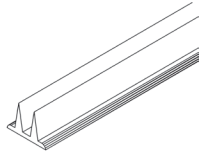

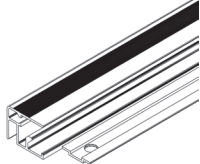

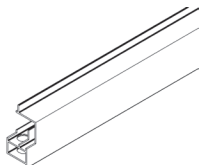
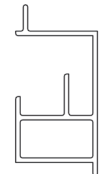
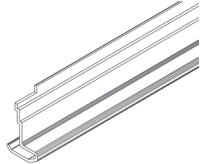
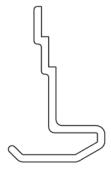
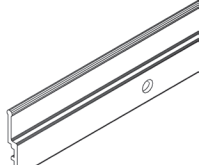
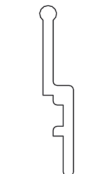
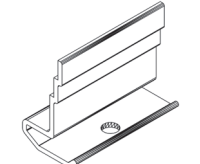
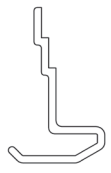
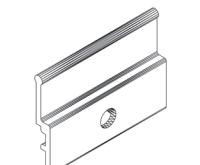
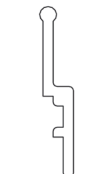
Pack 2					Required Quantity / Model					Profile
Item No.	Part	Section Ref.	Size mm	Quantity in Carton	8100	10000	11900	13800	15700	
7090		5	324	1	2	2	3	3	3	
7201		2	1539	1	2	1	-	-	-	
7202		2	1539	1	2	1	-	-	-	
7213		7a	1539	2	4	2	-	-	-	
7244		5	713	1	2	2	3	3	3	
7247 (7291)		5	674	1	2	2	3	3	3	
7248 (7291)		5	674	1	2	2	3	3	3	
7249		4b	1251	1	3	4	5	6	7	
7250		4a	1520	1	2	1	-	-	-	

ZEUS 2

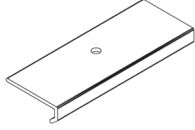

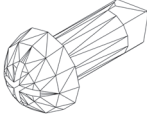
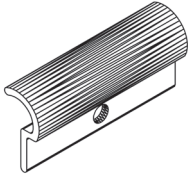

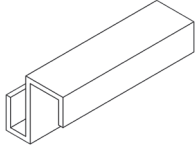
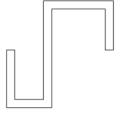
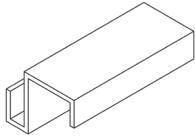
Part List

Pack 2					Required Quantity / Model					Profile
Item No.	Part	Section Ref.	Size mm	Quantity in Carton	8100	10000	11900	13800	15700	
7255		4b	1356	2	4	6	8	10	12	
7257		4a	1520	2	4	2	-	-	-	
7291 (7247 & 7248)		5	674	2	4	4	6	6	6	
7293		5	713	1	2	2	3	3	3	
7294		4b	708	1	2	2	3	3	3	
7296		7a	707	4	8	10	12	14	16	
7297		7a	687	4	8	10	12	14	16	
7298		7a*	30	4	8*	10*	12*	14*	16*	
7299		7a*	30	4	8*	10*	12*	14*	16*	

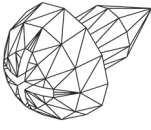
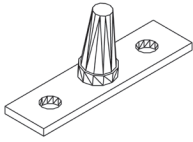
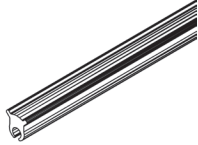

Part List

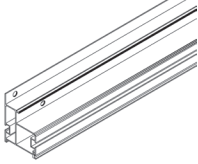
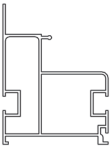
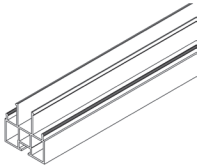
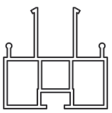
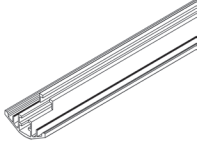
Pack 2					Required Quantity / Model					
Item No.	Part	Section Ref.	Size mm	Quantity in Carton	8100	10000	11900	13800	15700	Profile
7343		7a	56	2	4	6	8	10	12	
7349		7a 8	3.9x10	16	38	46	56	64	72	
7369		8	30	2	4	4	6	6	6	
7406		7b	30	4	14	16	18	20	22	
7407		7b	30	4	14	16	18	20	22	

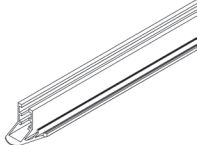
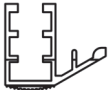
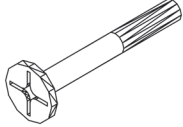
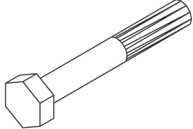
Part List



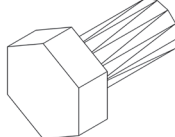

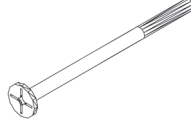
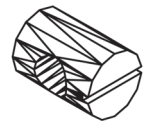
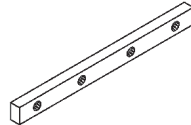
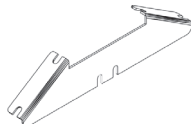
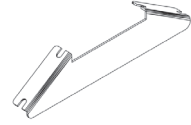
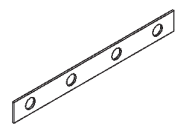
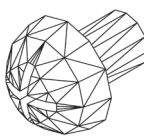

Pack 3					Required Quantity / Model					
Item No.	Part	Section Ref.	Size mm	Quantity in Carton	8100	10000	11900	13800	15700	Profile
1006		4b 5 6a 6b 9	3.5x6	6	32	32	38	38	38	
6056		4b	46	2	4	4	6	6	6	
6090		7b 7c	19000	1	77000	85500	94000	103000	112000	
7002		1	2264	2	-	2	4	2	-	
7005		3	1775	4	6	8	10	12	14	
7032		7b	1793	4	6	8	10	12	14	
7034		7b 7c	733	6	16	18	20	22	24	
7047		4b	M6x48	3	2	4	4	6	8	
7050		7b	M6x42	31	126	138	150	162	174	

Part List

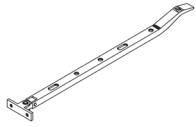
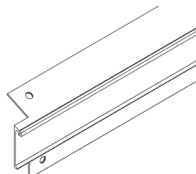
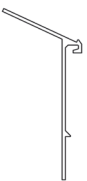
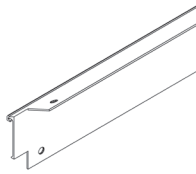
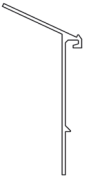
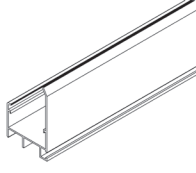
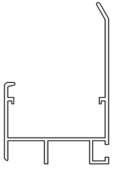
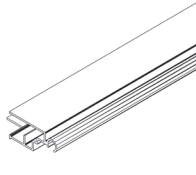

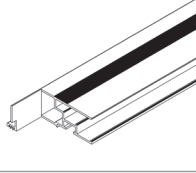
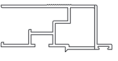
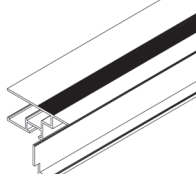

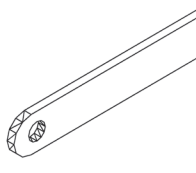

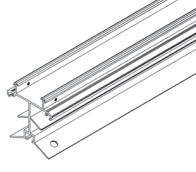
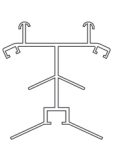
Pack 3					Required Quantity / Model					Profile
Item No.	Part	Section Ref.	Size mm	Quantity in Carton	8100	10000	11900	13800	15700	
7052		1, 2 3, 4 5, 6 7a	M6x12	52	154	176	202	224	246	
7053		1, 2 3, 4 5, 6 7, 8	M6x4	83	307	341	379	413	447	
7054		4b 6	M6x100	2	12	12	14	14	14	
7055		4b 6	M6x10 x14	2	12	12	14	14	14	
7061		1 2 4a 7a	117	3	15	15	15	15	15	
7062		4	235	2	6	7	8	9	10	
7063		3	255	4	8	10	12	14	16	
7064		1 2 4a 7a	117	3	11	11	11	11	11	
7080		1 2 4a 7a	M6x8	12	60	60	60	60	60	

ZEUS 2

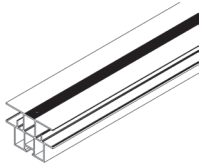
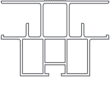
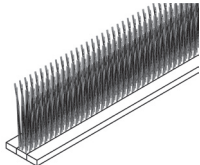
Part List

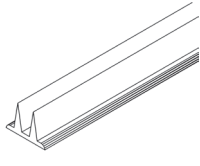

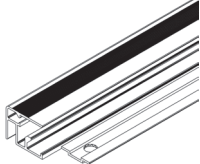

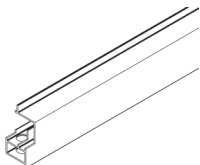
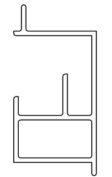
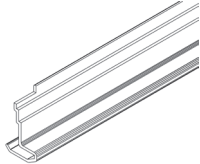
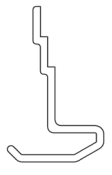
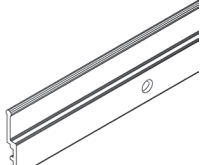
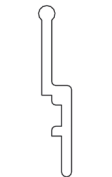
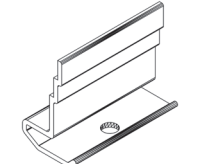
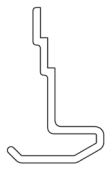
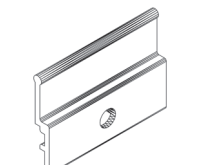
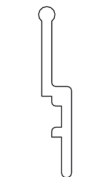

Pack 3					Required Quantity / Model					Profile
Item No.	Part	Section Ref.	Size mm	Quantity in Carton	8100	10000	11900	13800	15700	
7090		5	324	1	2	2	3	3	3	
7203		2	2283	1	-	1	2	1	-	
7204		2	2283	1	-	1	2	1	-	
7214		7a	2283	2	-	2	4	2	-	
7244		5	713	1	2	2	3	3	3	
7247 (7291)		5	674	1	2	2	3	3	3	
7248 (7291)		5	674	1	2	2	3	3	3	
7249		4b	1251	2	3	4	5	6	7	
7251		4a	2264	1	-	1	2	1	-	



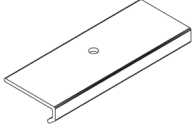

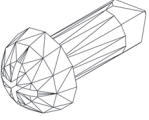
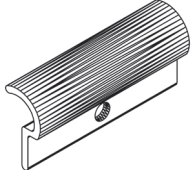
Part List

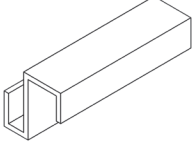
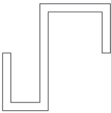
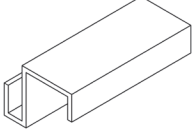
Pack 3					Required Quantity / Model					
Item No.	Part	Section Ref.	Size mm	Quantity in Carton	8100	10000	11900	13800	15700	Profile
7255		4b	1356	4	4	6	8	10	12	
7258		4a	2264	2	-	2	4	2	-	
7291 (7247 & 7248)		5	674	2	4	4	6	6	6	
7293		5	713	1	2	2	3	3	3	
7294		4b	708	1	2	2	3	3	3	
7296		7a	707	6	8	10	12	14	16	
7297		7a	687	6	8	10	12	14	16	
7298		7a*	30	6	8*	10*	12*	14*	16*	
7299		7a*	30	6	8*	10*	12*	14*	16*	



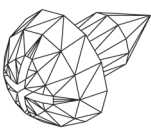
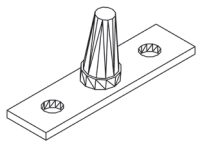
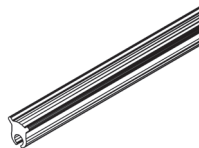

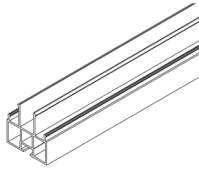
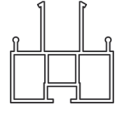
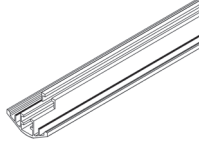
ZEUS 2

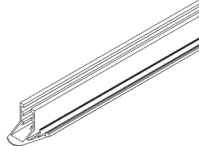
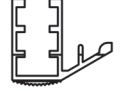
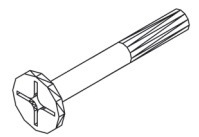
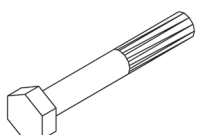
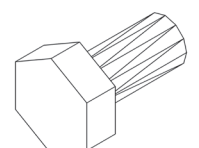
Part List





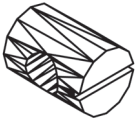
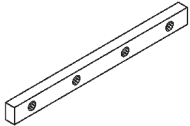
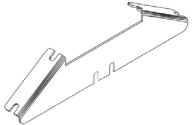

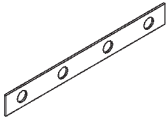
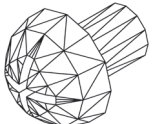
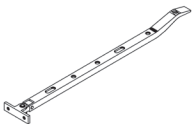

Pack 3					Required Quantity / Model					
Item No.	Part	Section Ref.	Size mm	Quantity in Carton	8100	10000	11900	13800	15700	Profile
7343		7a	56	4	4	6	8	10	12	
7349		7a 8	3.9x10	24	38	46	56	64	72	
7369		8	30	2	4	4	6	6	6	
7406		7b	30	6	14	16	18	20	22	
7407		7b	30	6	14	16	18	20	22	

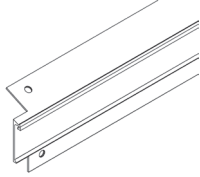
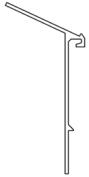
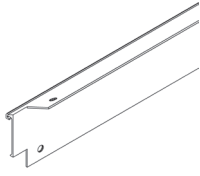
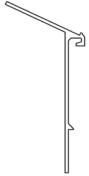
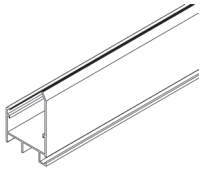
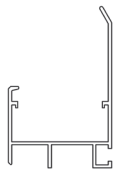
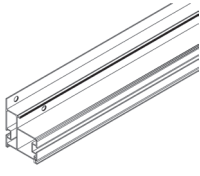
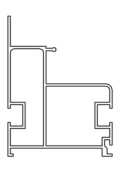
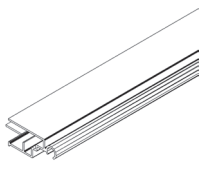
Pack 4					Required Quantity / Model					
Item No.	Part	Section Ref.	Size mm	Quantity in Carton	8100	10000	11900	13800	15700	Profile
1006		4b 5 6a 6b 9	3.5x6	6	32	32	38	38	38	
6056		4b	46	2	4	4	6	6	6	
6090		7b 7c	28000	1	77000	85500	94000	103000	112000	
7005		3	1775	6	6	8	10	12	14	
7032		7b	1793	6	6	8	10	12	14	
7034		7b 7c	733	8	16	18	20	22	24	
7047		4b	M6x48	5	2	4	4	6	8	
7050		7b	M6x42	43	126	138	150	162	174	
7052		1, 2 3, 4 5, 6 7a	M6x12	74	154	176	202	224	246	

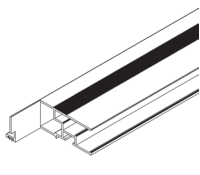
Part List

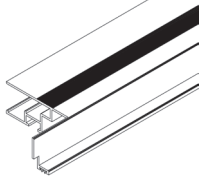

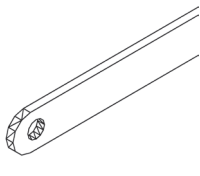

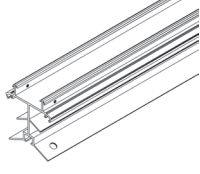
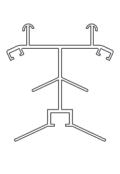





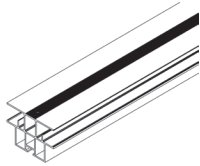

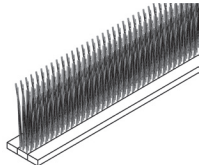
Pack 4					Required Quantity / Model					
Item No.	Part	Section Ref.	Size mm	Quantity in Carton	8100	10000	11900	13800	15700	Profile
7053		1, 2 3, 4 5, 6 7, 8	M6x4	117	307	341	379	413	447	
7054		4b 6	M6x100	2	12	12	14	14	14	
7055		4b 6	M6x10 x14	2	12	12	14	14	14	
7061		1 2 4a 7a	117	3	15	15	15	15	15	
7062		4	235	3	6	7	8	9	10	
7063		3	255	6	8	10	12	14	16	
7064		1 2 4a 7a	117	3	11	11	11	11	11	
7080		1 2 4a 7a	M6x8	12	60	60	60	60	60	
7090		5	324	1	2	2	3	3	3	

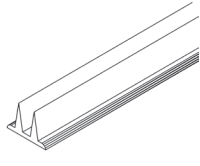
Part List

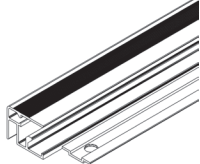

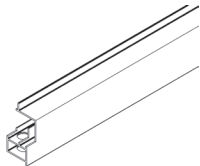
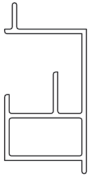
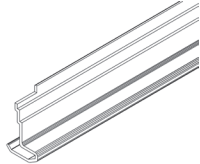
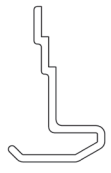
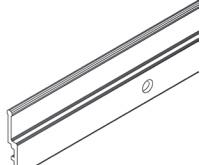

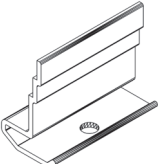
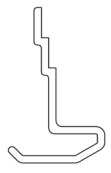
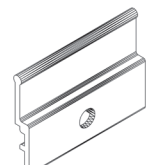

Pack 4					Required Quantity / Model					
Item No.	Part	Section Ref.	Size mm	Quantity in Carton	8100	10000	11900	13800	15700	Profile
7205		2	3027	1	-	-	-	1	2	
7206		2	3027	1	-	-	-	1	2	
7215		7a	3027	2	-	-	-	2	4	
7224		1	3008	2	-	-	-	2	4	
7244		5	713	1	2	2	3	3	3	
7247 (7291)		5	674	1	2	2	3	3	3	
7248 (7291)		5	674	1	2	2	3	3	3	
7249		4b	1251	3	3	4	5	6	7	
7252		4a	3008	1	-	-	-	1	2	

ZEUS 2

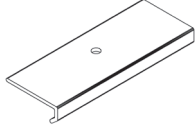

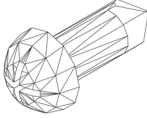
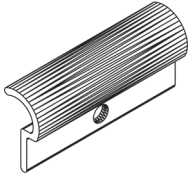

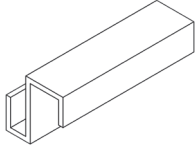
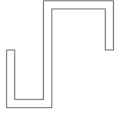
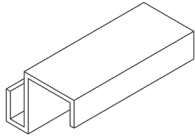
Part List

Pack 4					Required Quantity / Model					Profile
Item No.	Part	Section Ref.	Size mm	Quantity in Carton	8100	10000	11900	13800	15700	
7255		4b	1356	6	4	6	8	10	12	
7259		4a	3008	2	-	-	-	2	4	
7291 (7247 & 7248)		5	674	2	4	4	6	6	6	
7293		5	713	1	2	2	3	3	3	
7294		4b	708	1	2	2	3	3	3	
7296		7a	707	8	8	10	12	14	16	
7297		7a	687	8	8	10	12	14	16	
7298		7a*	30	8	8*	10*	12*	14*	16*	
7299		7a*	30	8	8*	10*	12*	14*	16*	



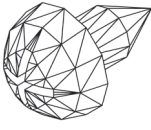
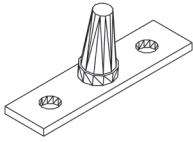
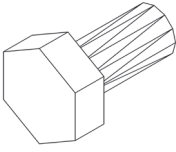

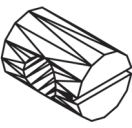
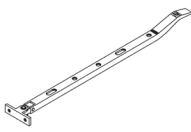
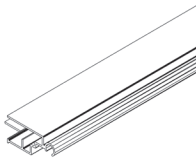

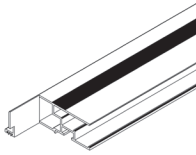
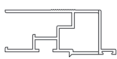
Part List

Pack 4					Required Quantity / Model					
Item No.	Part	Section Ref.	Size mm	Quantity in Carton	8100	10000	11900	13800	15700	Profile
7343		7a	56	6	4	6	8	10	12	
7349		7a 8	3.9x10	32	38	46	56	64	72	
7369		8	30	2	4	4	6	6	6	
7406		7b	30	8	14	16	18	20	22	
7407		7b	30	8	14	16	18	20	22	

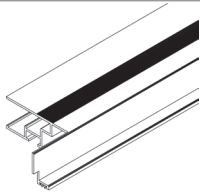
Part List

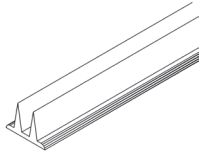
Pack 5 - Roof Vent					Required Quantity / Model					
Item No.	Part	Section Ref.	Size mm	Quantity in Carton	8100	10000	11900	13800	15700	Profile
1006		4b 5 6a 6b 9	3.5x6	6	32	32	38	38	38	
6056		4b	46	2	4	4	6	6	6	
7052		1, 2 3, 4 5, 6 7a	M6x12	4	154	176	202	224	246	
7053		1, 2 3, 4 5, 6 7, 8	M6x4	4	307	341	379	413	447	
7054		4b 6	M6x100	2	12	12	14	14	14	
7055		4b 6	M6x10 x14	2	12	12	14	14	14	
7090		5	324	1	2	2	3	3	3	
7244		5	713	1	2	2	3	3	3	
7247 (7291)		5	674	1	2	2	3	3	3	

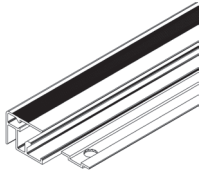
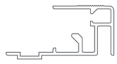
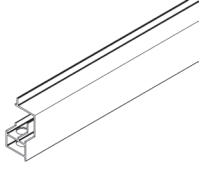
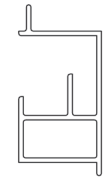
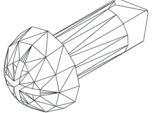
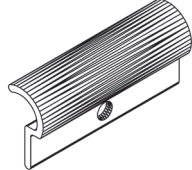
Part List

Pack 5 - Roof Vent					Required Quantity / Model					
Item No.	Part	Section Ref.	Size mm	Quantity in Carton	8100	10000	11900	13800	15700	Profile
7248 (7291)		5	674	1	2	2	3	3	3	
7291 (7247 & 7248)		5	674	2	4	4	6	6	6	
7293		5	713	1	2	2	3	3	3	
7294		4b	708	1	2	2	3	3	3	
7349		7a 8	3.9x10	2	38	46	56	64	72	
7369		8	30	2	4	4	6	6	6	



IMPORTANT:

Materials and tools for the preparation of the suggested foundation are not included in this product.



The following foundation specifications are suggestions only.

For the erection of this greenhouse we suggest a solid foundation. It is possible to prepare this foundation from concrete, brickwork or stonework. If you have no experience with the construction of such a foundation please consult a company specialising in this work.

Important: The foundation must extend down below the frost level. The specified dimensions are to be followed exactly and allow for the connection of the sill bar to the foundation, using the supplied connecting angles 7095, inside or outside the greenhouse. The angle 7095 requires 50mm space.



IMPORTANT:

The foundation must be exactly right angular and level. To achieve this you will require a spirit level and a right angle.

(Tip: If the distance between the two opposite corners is the same then the foundation is right angular.)

Assemble your greenhouse onto your prepared foundation.

Important:

The greenhouse should be connected to the foundation only after the greenhouse is completely assembled and it has been checked to be exactly right angular and level.

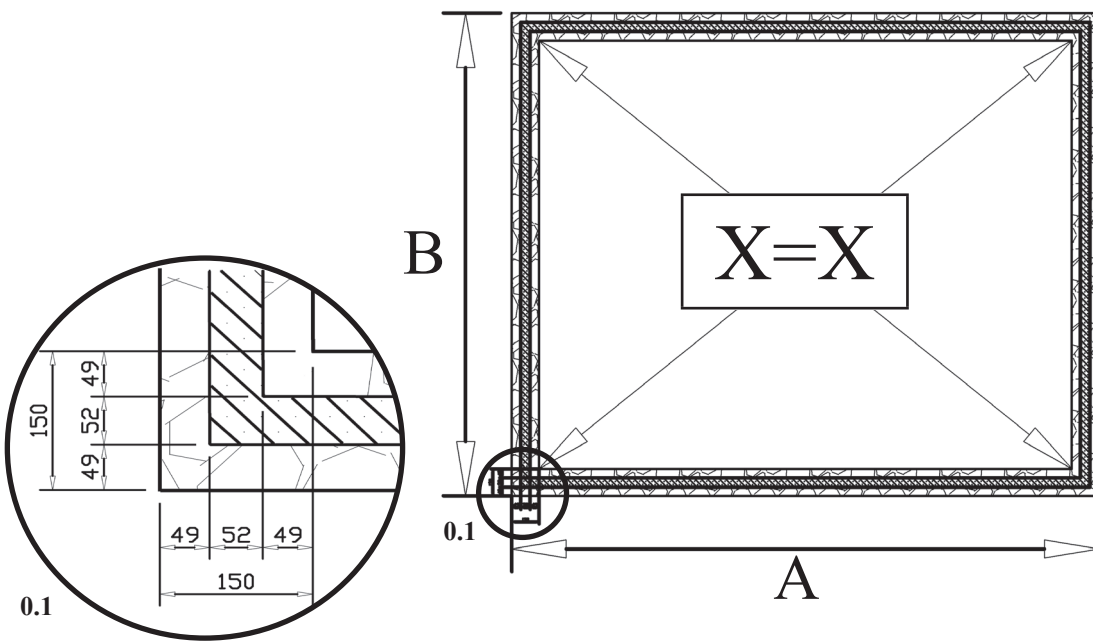
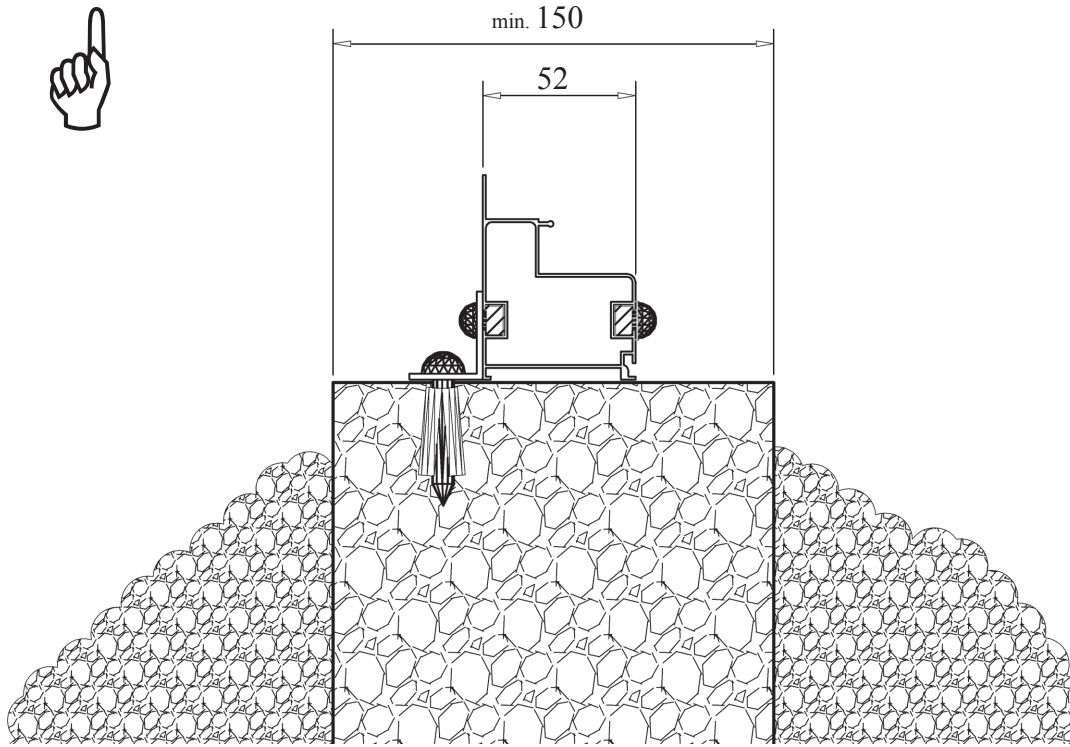

	8100	10000	11900	13800	15700
A	3242 mm	3986 mm	4730 mm	5474 mm	6218 mm
B	2662 mm	2662 mm	2662 mm	2662 mm	2662 mm

1

Model				
8100	10000	11900	13800	15700
7001				
4	2	0	0	0
7002				
0	2	4	2	0
7003				
2	2	2	2	2
7004				
2	2	2	2	2
7052				
8	8	8	8	8
7053				
8	8	8	8	8
7061				
8	8	8	8	8
7064				
4	4	4	4	4
7080				
32	32	32	32	32
7095				
4	4	4	4	4
7200				
4	4	4	4	4
7224				
0	0	0	2	4
7236				
4	4	4	4	4

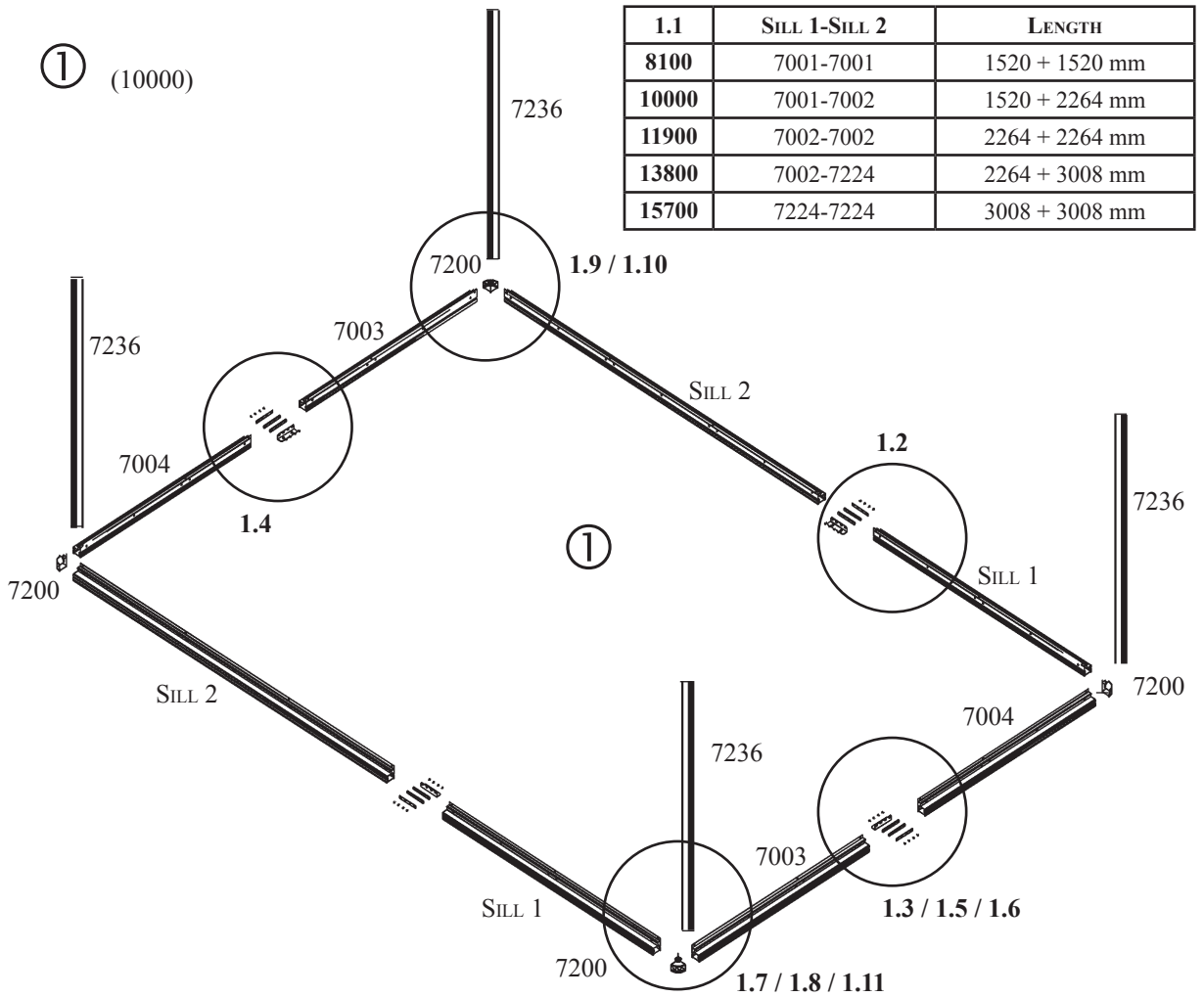

1.1	SILL 1-SILL 2	LENGTH
8100	7001-7001	1520 + 1520 mm
10000	7001-7002	1520 + 2264 mm
11900	7002-7002	2264 + 2264 mm
13800	7002-7224	2264 + 3008 mm
15700	7224-7224	3008 + 3008 mm

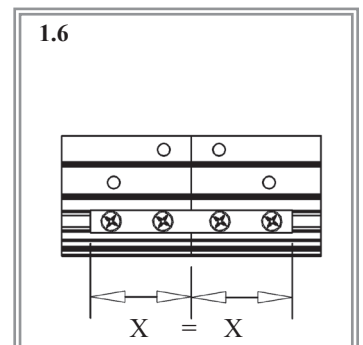
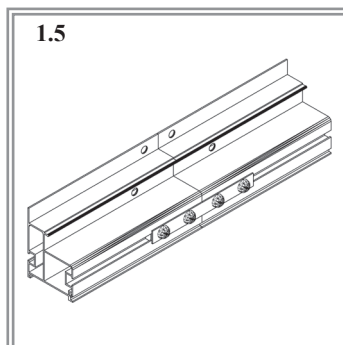
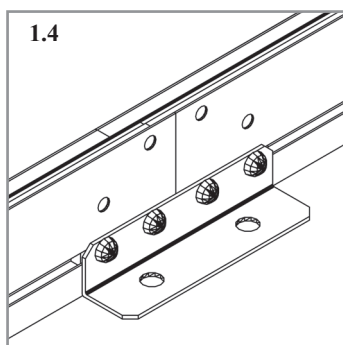
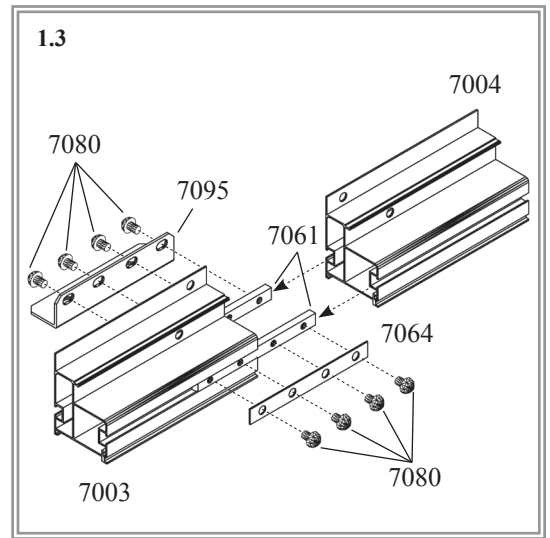
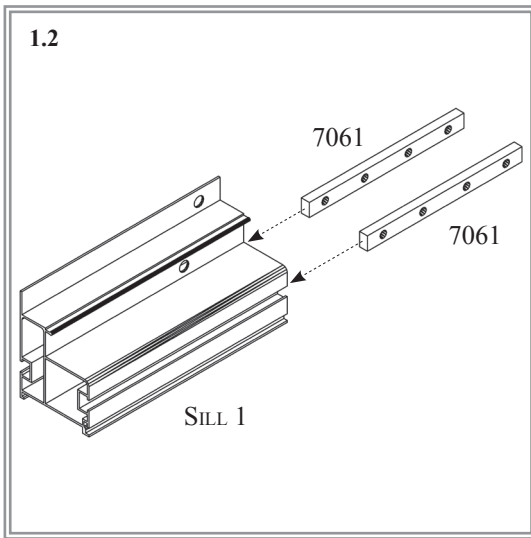

SILL BARS / CORNER POSTS

ATTENTION ...

The sill bars, using angles 7095, should be connected to the foundation only after the house is **completely** assembled.

It is recommended that this greenhouse be assembled by at least 2 people.

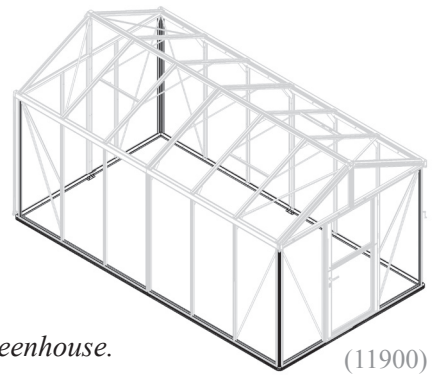

Diagrams in a single frame (as 1.4) show the view from inside the greenhouse.

Diagrams in a double frame (as 1.2) show the view from outside the greenhouse.

Remove sill bars 7003 and 7004 from Pack 1-2 and sill bars 7001, 7002 or 7224 from Packs 2, 3 or 4 as required, see table (1.1). Lay them on the prepared foundation as shown in diagram ①. Connect them by sliding connecting blocks 7061 into the channels in the sill bars (1.2) and loosely fix them in place using plates 7064 or angles 7095 and screws 7080 (1.3) (1.4) (1.5). Ensure the assembled connectors are centred on the join of the sill bars (1.6) and tighten all screws 7080 (1.6).

Connect the four assembled sill sides together by inserting the corner plastics 7200 into the channels in the sill bars (1.7) (1.8).

Loosely prepare bolts 7052 and nuts 7053 as shown in (1.9). Lower corner bar 7236 fitting the bolt heads of 7052 into the bolt channels in 7236 (1.9) and ensuring 7236 fits over the guides in the top of 7200 (1.11). Tighten nuts 7053 (1.10).

When all four corners are connected check that the sill sides are at right angles to one another.

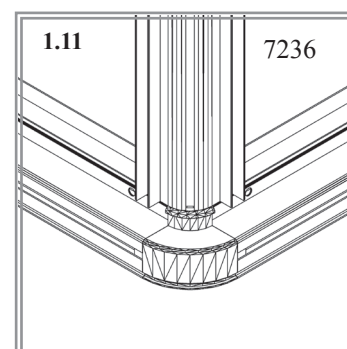
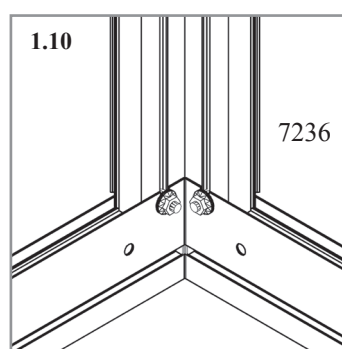
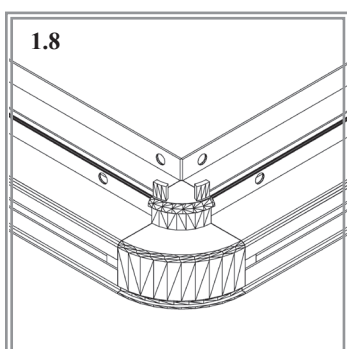
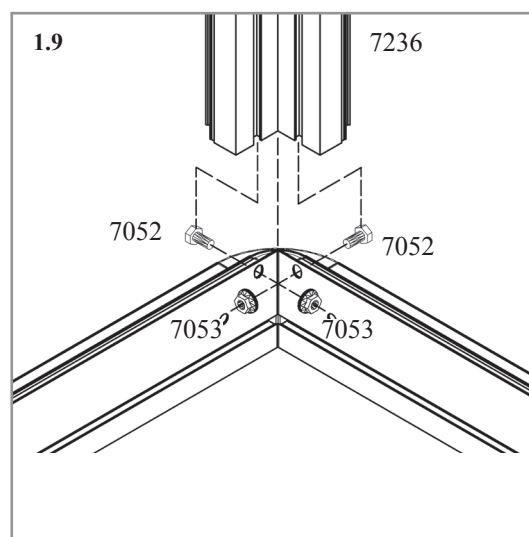
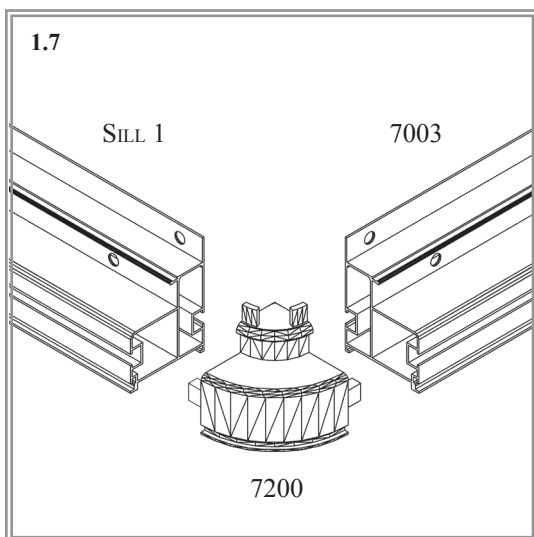

Model				
8100	10000	11900	13800	15700
7006				
3	3	3	3	3
7010				
2	2	2	2	2
7011				
2	2	2	2	2
7014				
1	1	1	1	1
7045				
1	1	1	1	1
7052				
32	32	32	32	32
7053				
32	32	32	32	32
7061				
4	4	4	4	4
7064				
4	4	4	4	4
7080				
16	16	16	16	16
7201				
2	1	0	0	0
7202				
2	1	0	0	0
7203				
0	1	2	1	0
7204				
0	1	2	1	0
7205				
0	0	0	1	2
7206				
0	0	0	1	2

② (10000)

2.1	EAVE1-EAVE2-EAVE3-EAVE4	LENGTH (EAVE 1/EAVE 2) + (EAVE 3/EAVE 4)
8100	7201-7202-7201-7202	1539 + 1539 mm
10000	7201-7202-7203-7204	1539 + 2283 mm
11900	7203-7204-7203-7204	2283 + 2283 mm
13800	7203-7204-7205-7206	2283 + 3027 mm
15700	7205-7206-7205-7206	3027 + 3027 mm

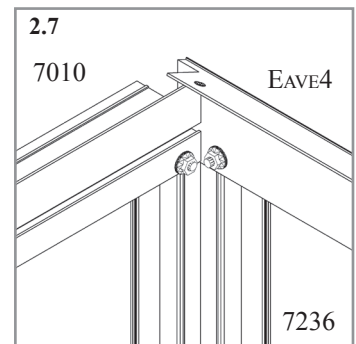
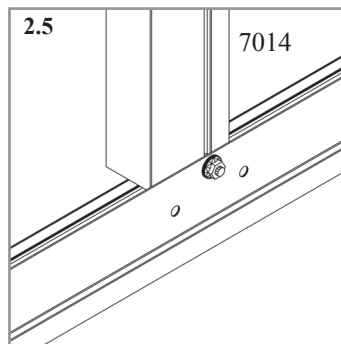
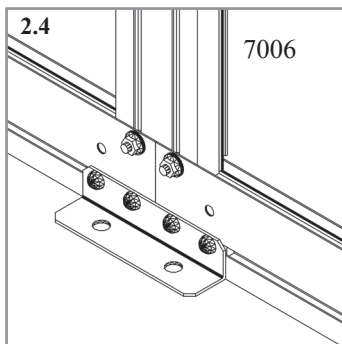
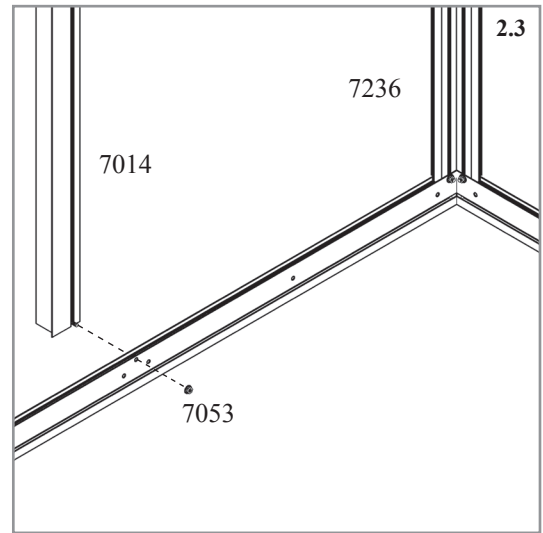
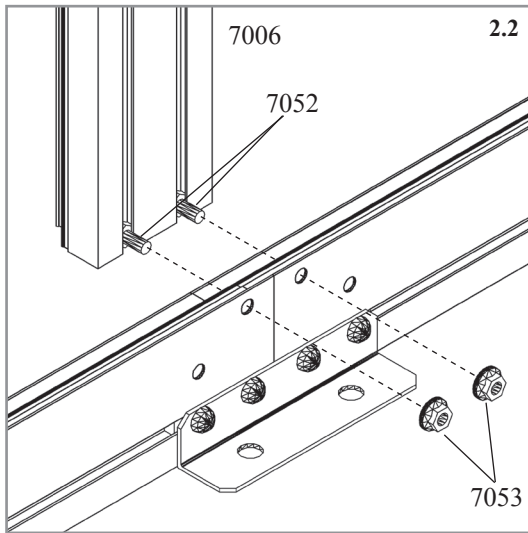
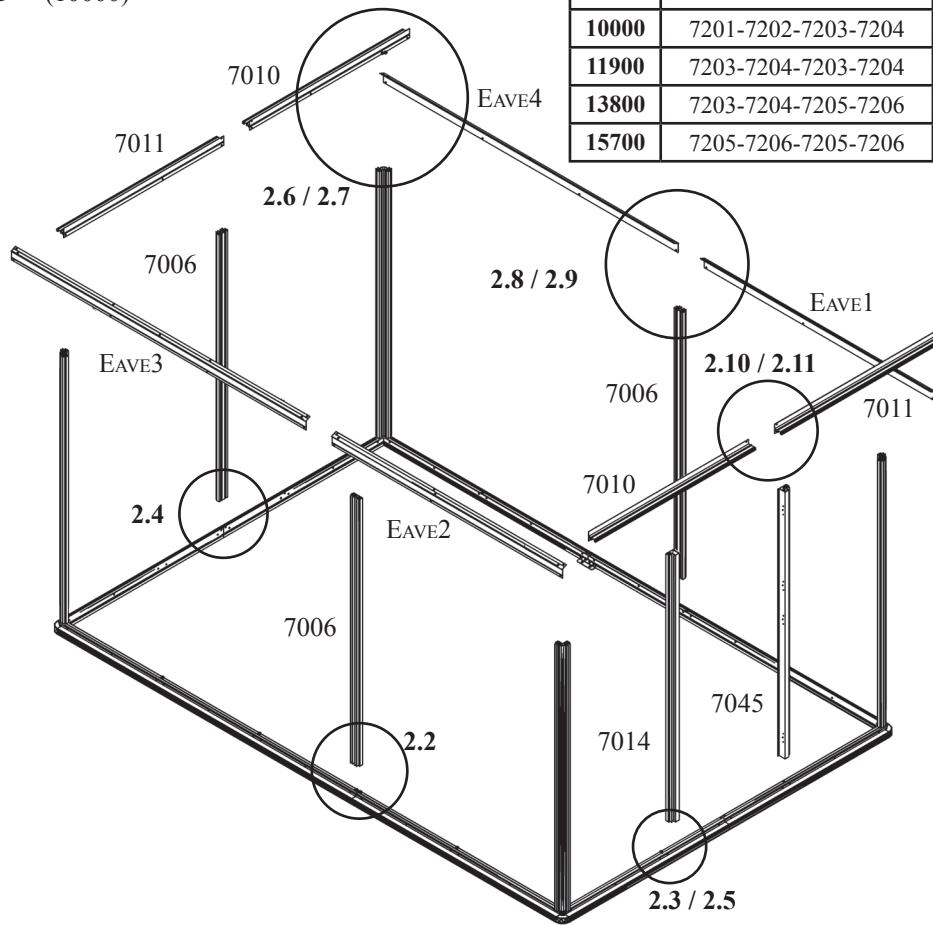

ZEUS 2

MIDDLE BARS / EAVE ANGLES

ATTENTION ...

This step will require 2 to 3 people to assemble.

Please connect all nuts and bolts loosely as some must be removed again to assemble other parts later.

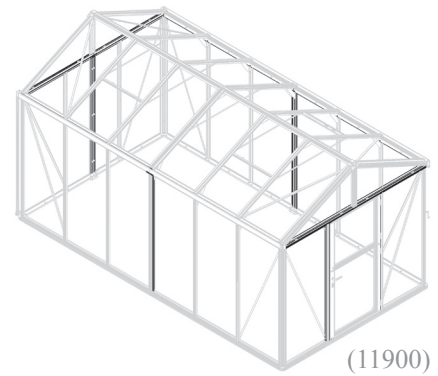

Please insert in two of the middle bars 7006, in each bolt channel, two extra bolts 7052 with nuts 7053 to later connect braces 7063 (2.9). Connect these prepared 7006 onto the sides by inserting bolts 7052 into the bolt channels and connect to the sill bar using nuts 7053 (2.2). Connect middle bars 7006 and the corner posts 7236 to the eave angles, table 2.1 (2.6 - 2.9). Please take care to ensure that the eave angles are pushed into the corner of 7236 (2.6) and that the assembly edge sits correctly (2.8).





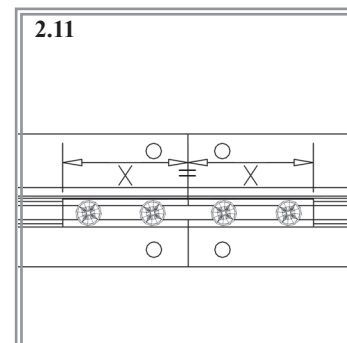
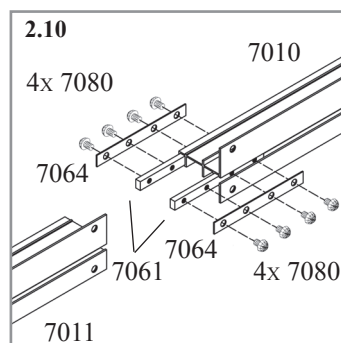
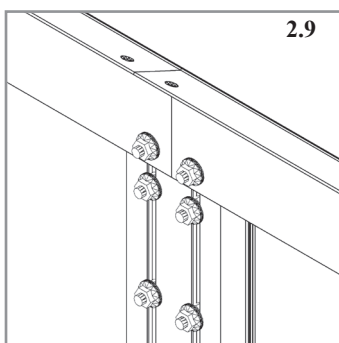
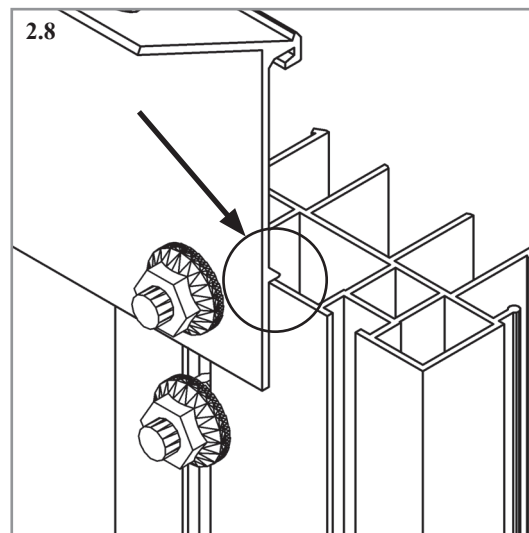
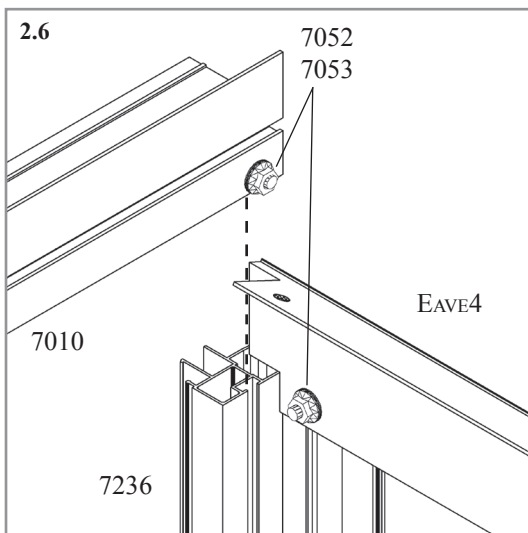

Connect end bars 7010 and 7011 together using connection assembly 7061, 7064 and 7080 (2.10). Ensure the assembled connectors are centred on the join of the sill bars (2.11) and tighten all screws 7080.

Assemble 7010 / 7011 between corner bars 7236 at the front and rear of the house using bolts 7052 and nuts 7053 (2.6) (2.7). Connect middle bars, 7006 at the rear and 7014 and 7045 at the front, by inserting bolts 7052 into the bolt channels and connect to the sill bars and 7010 / 7011 using nuts 7053 (2.2 - 2.5).



Middle Bars / Eave Angles

ZEUS 2

Model				
8100	10000	11900	13800	15700
7005				
6	8	10	12	14
7052				
28	36	44	52	60
7053				
28	36	44	52	60
7063				
8	10	12	14	16
7069				
4	4	4	4	4
7219				
2	2	2	2	2
7269				
4	4	4	4	4

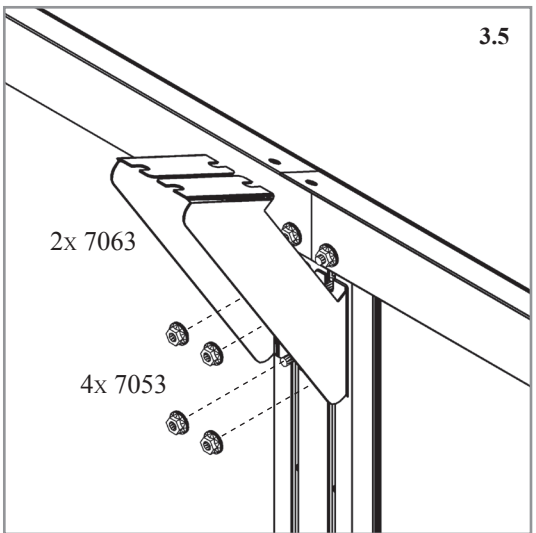
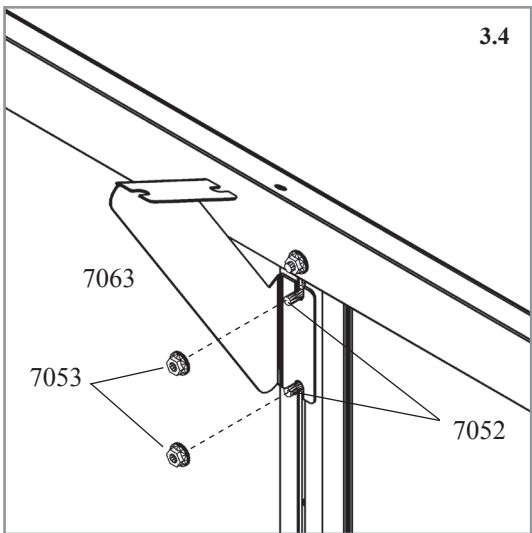
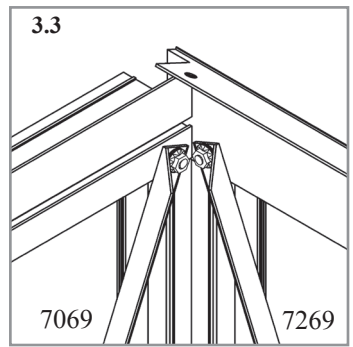
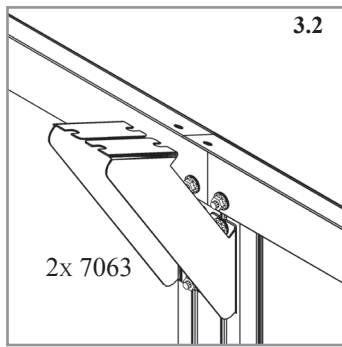
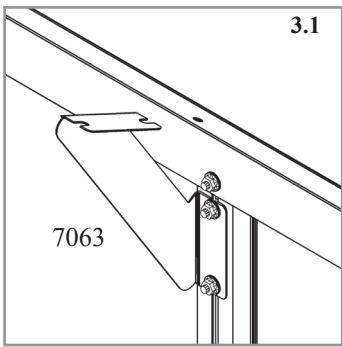
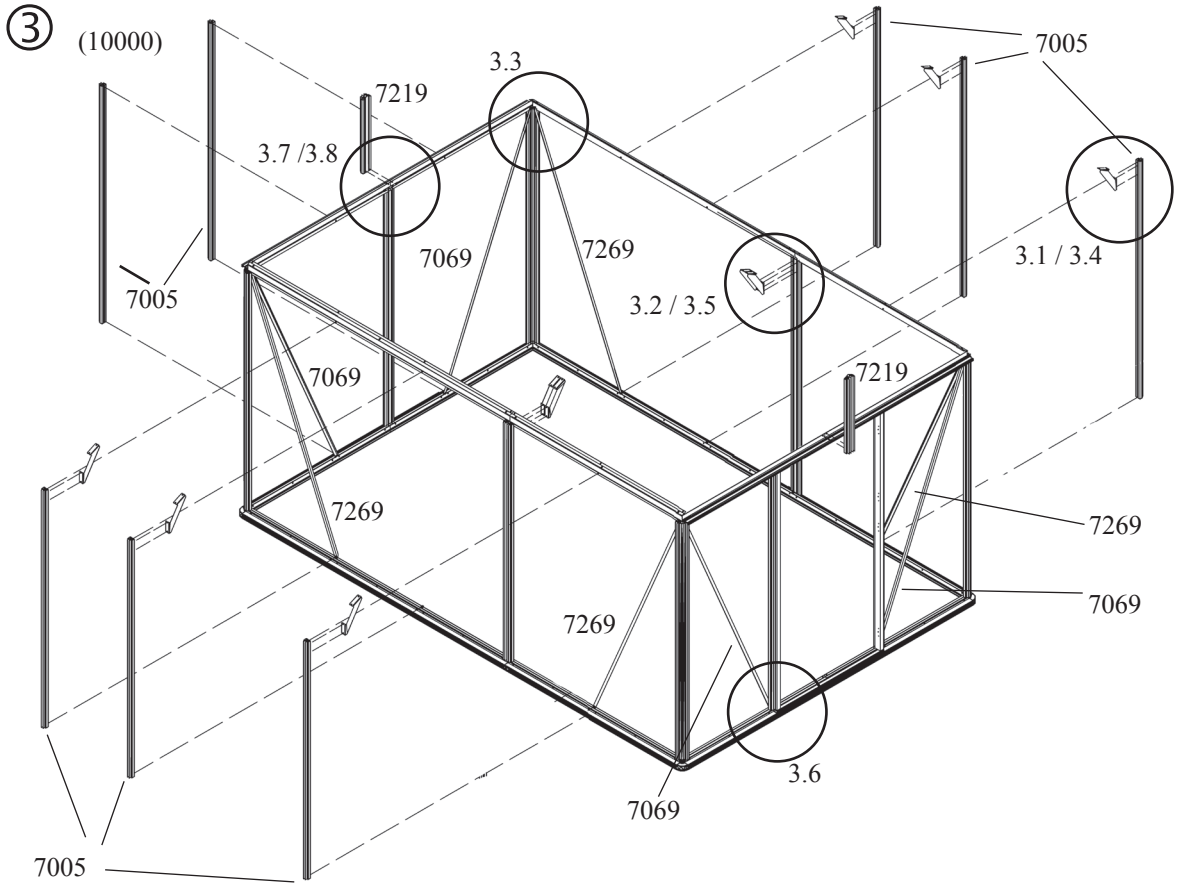

MIDDLE BARS

PLEASE NOTE ...

In this assembly step the diagonal braces 7069 and 7269 will be assembled. To achieve this previous connections must be released. It can then appear as if the diagonal braces are too long or too short. If the house is then pulled in the required direction at the eave bar it will be possible to achieve the correct fit of all braces.

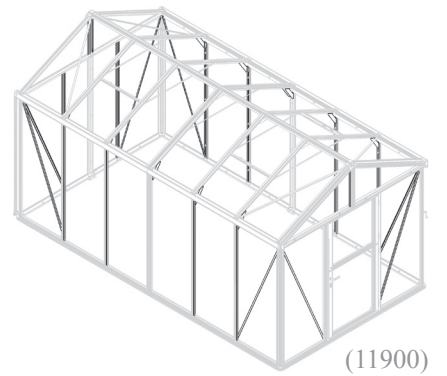

Please take the following quantity of middle bars 7005: Model 8100 - 4, Model 10000 - 6, Model 11900 - 8, Model 13800 - 10, Model 15700 - 12; and insert two extra bolts 7052 into the bolt channels of each fixing them loosely with nuts 7053. Assemble these prepared 7005 in the side walls as shown in diagram ③. Use the extra bolts included in the bolt channels of middle bars 7005 and 7006 to loosely assemble the braces 7063 (3.1, 3.2, 3.4, 3.5). The exact height of 7063 will be adjusted later when the roof is assembled.

At the rear of the house assemble the remaining middle bars 7005 as shown in ③.

Assemble diagonal braces 7069 and 7269 (3.3) (3.6). If they appear to have the wrong length adjust the house in the diagonal until they fit.

Assemble the ridge support 7219 (3.7) (3.8) and include one extra bolt 7052 with nut 7053 in both of the bolt channels in 7219 (3.7) (4a.3).

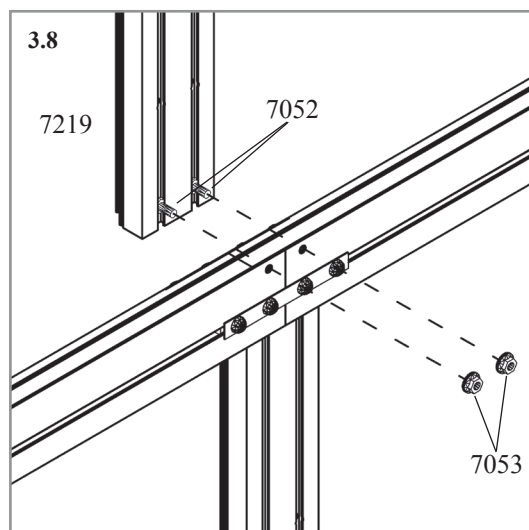
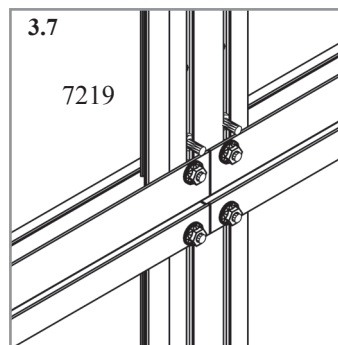
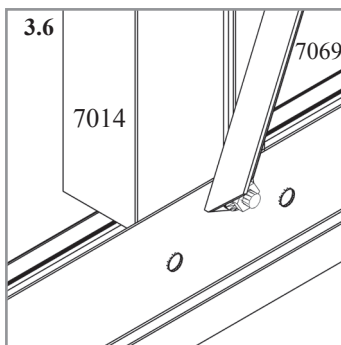

4a

④ a (10000)

4a.1	RIDGE 1-RIDGE 2	LENGTH
8100	7250-7250	1520 + 1520 mm
10000	7250-7251	1520 + 2264 mm
11900	7251-7251	2264 + 2264 mm
13800	7251-7252	2264 + 3008 mm
15700	7252-7252	3008 + 3008 mm

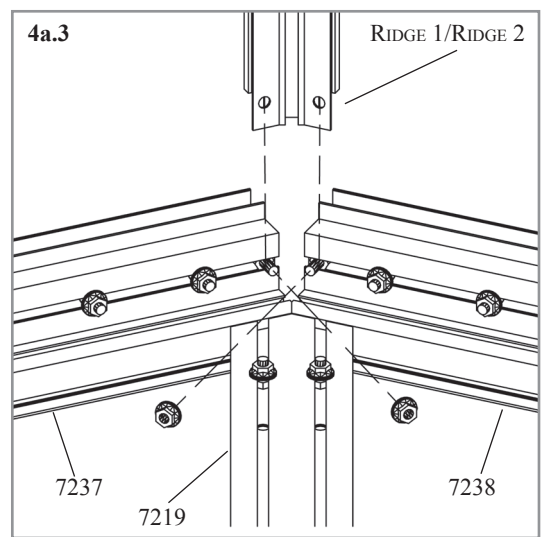
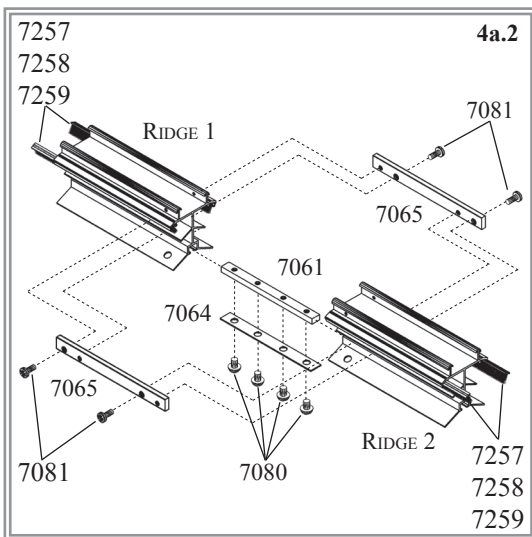
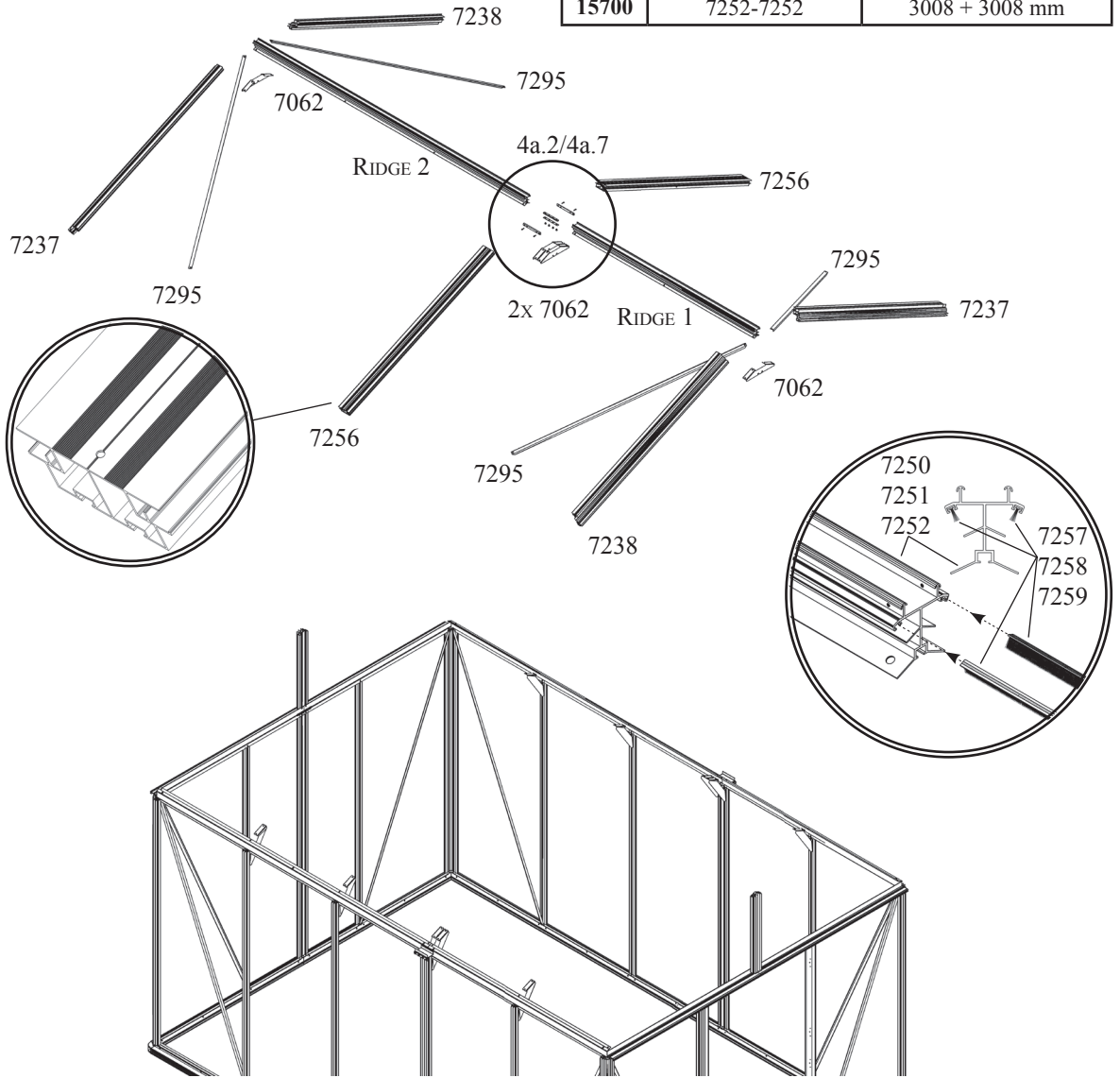

Model				
8100	10000	11900	13800	15700
7052				
40	40	40	40	40
7053				
40	40	40	40	40
7061				
1	1	1	1	1
7062				
4	4	4	4	4
7064				
1	1	1	1	1
7065				
2	2	2	2	2
7080				
4	4	4	4	4
7081				
4	4	4	4	4
7237				
2	2	2	2	2
7238				
2	2	2	2	2
7250				
2	1	0	0	0
7251				
0	1	2	1	0
7252				
0	0	0	1	2
7256				
2	2	2	2	2
7257				
4	2	0	0	0
7258				
0	2	4	2	0
7259				
0	0	0	2	4
7295				
4	4	4	4	4

ZEUS 2

GABEL / RIDGE BARS

PLEASE NOTE ...

This step will require 2 to 3 people to assemble. It is also advised to use two ladders.

Some nuts 7053 must be removed and reconnected to assemble new parts.

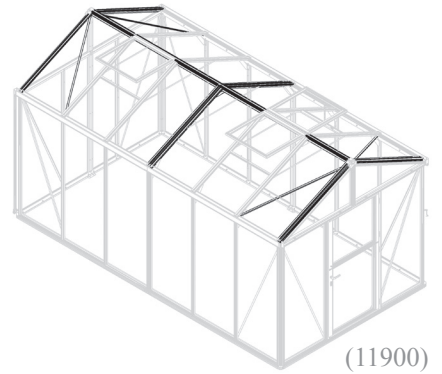

Begin by preparing the ridge bar using the ridge bar parts as listed in table 4a.1. Slide the plastic brush seals 7257, 7258 or 7259 as required into the channels on both sides of the ridge bars as shown. Connect both ridge bars using connection blocks 7061 / 7064 / 7080 and 7065 / 7081 (4a.2). Place the assembled ridge bar to the side.

Insert two extra bolts 7052 into the bolt channel in parts 7237 and 7238 and fix with nuts 7053 (4a.3). These are required to later assemble brace 7062.

Now rest 7237 and 7238 on ridge support 7219 (4a.3) (4a.4) and connect them to the eave angle using bolt 7052 and nut 7053.

Connect the prepared ridge bar assembly with roof corner bars 7237 and 7238 (4a.5). Connect brace 7062 using the prepared nuts and bolts in 7219, 7237 and 7238 (4a.6). Now assemble diagonal brace 7295 between the ridge (4a.6) and the eave angle (4a.8).

Prepare four extra nuts 7053 and bolts 7052 in each bolt channel of roof middle bar 7256 and assemble 7256 between the ridge and eave angle ④a. (Ensure the small hole on the outside surface of 7256 is at the eave bar.) Finally connect braces 7062 at the ridge (4a.7) and the prepared braces 7063 at the eave (4a.8).

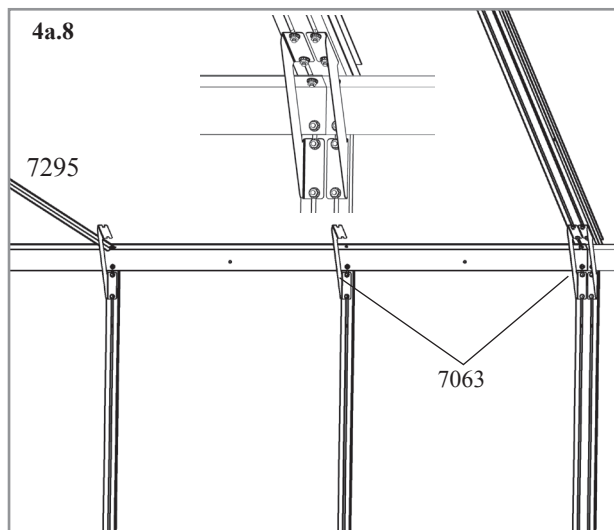
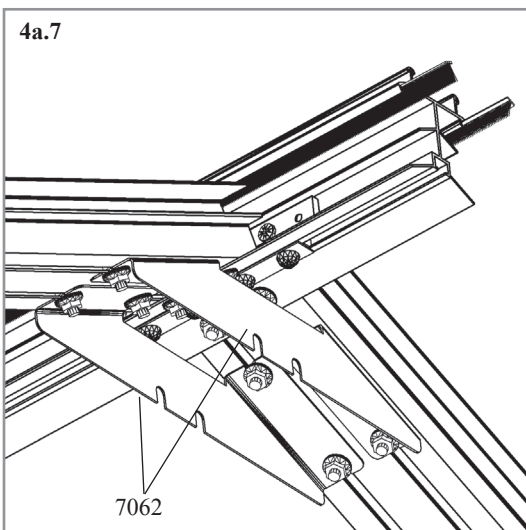
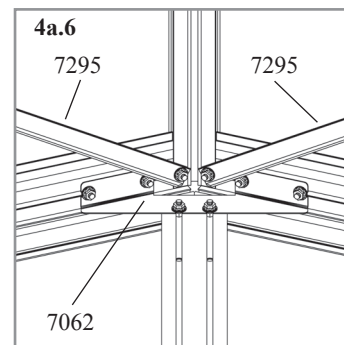
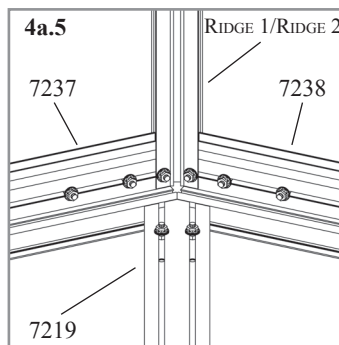
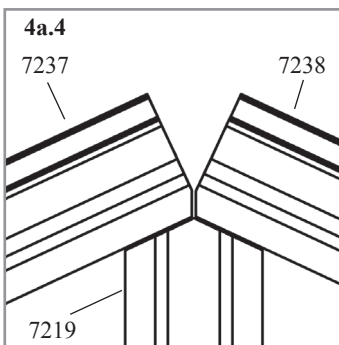

4b

④b (10000)

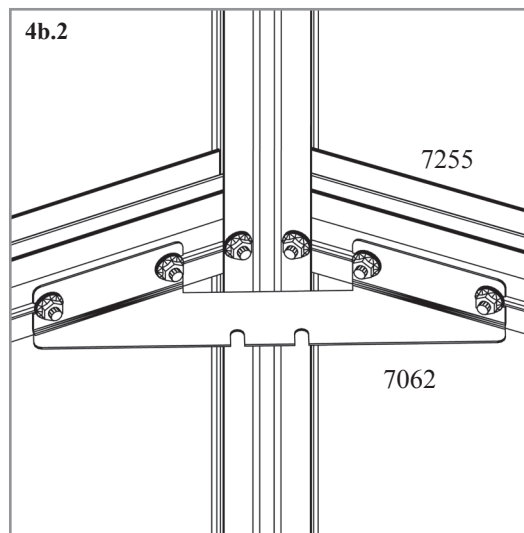
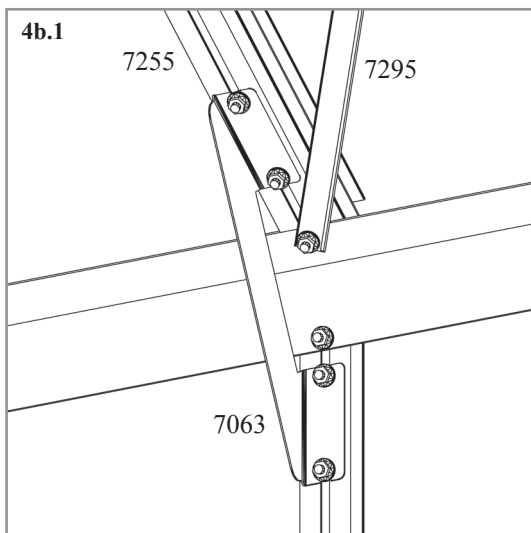
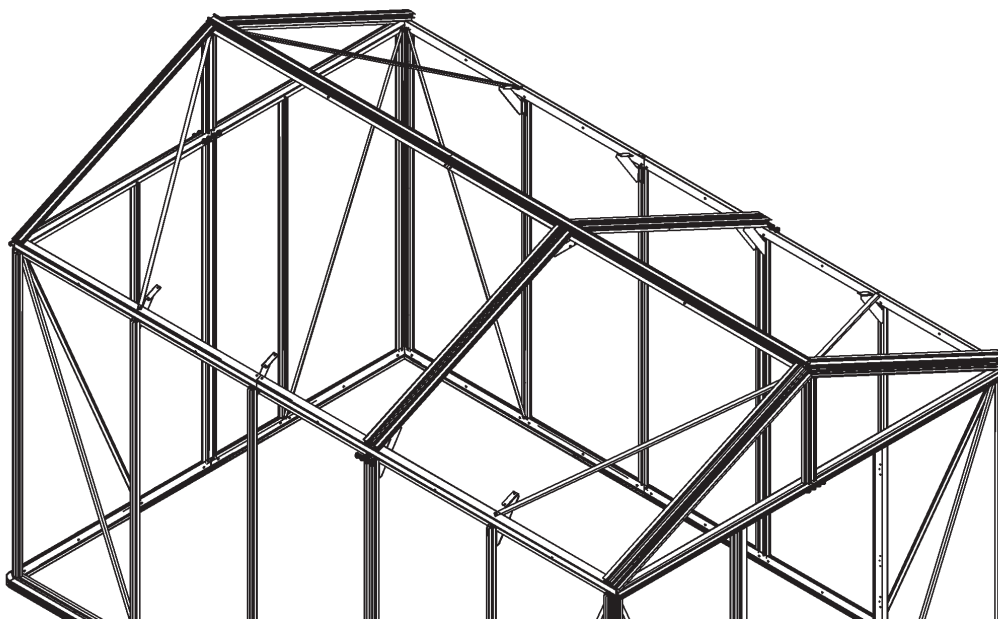
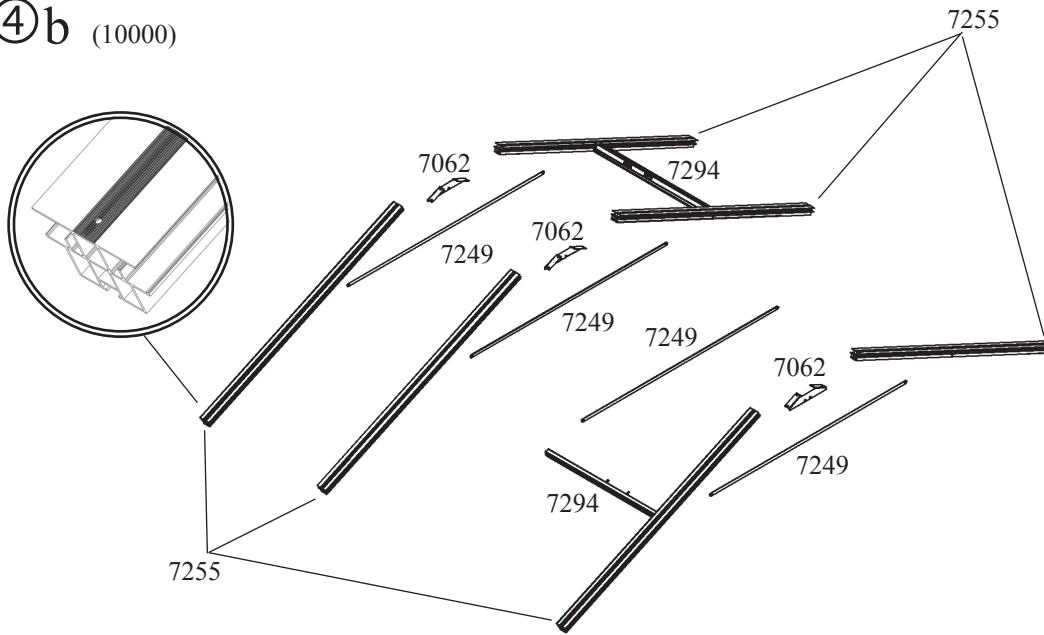

Model				
8100	10000	11900	13800	15700
1006				
8	8	12	12	12
6056				
4	4	6	6	6
7047				
2	4	4	6	8
7048				
0	1	2	2	2
7052				
24	36	48	60	72
7053				
24	36	48	60	72
7054				
4	4	6	6	6
7055				
4	4	6	6	6
7062				
2	3	4	5	6
7249				
3	4	5	6	7
7255				
4	6	8	10	12
7294				
2	2	3	3	3

ROOF MIDDLE BARS

PLEASE NOTE ...

This step will require 2 to 3 people to assemble. It is also advised to use two ladders.

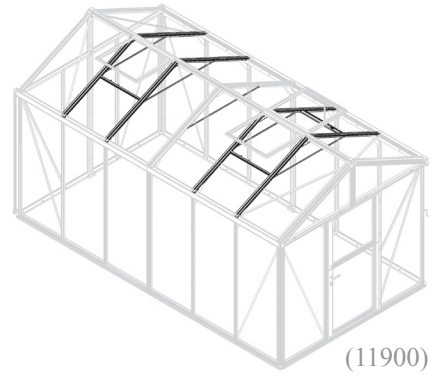

Begin by preparing the roof middle bars 7255 with four extra bolts 7052 in the bolt channel in each. Fix them in place loosely with nuts 7053.

Assemble 7255 between the eave angle bar (4b.1) and ridge bar (4b.2), ④b. (Ensure the small hole on the outside surface of 7255 is at the eave bar.) Connect braces 7062 at the ridge (4b.2) and the prepared braces 7063 at the eave (4b.1).

Assemble the roof vent sill 7294 and roof braces 7249 in the desired sections where the roof vents will later be positioned (4b.5) (4b.6). (*Note: Roof vents must be positioned opposite to one another or with at least one complete section between them. They cannot be assembled in the corner roof sections.*)

Connect the remaining roof braces 7249. (4b.3) (4b.4).

Assemble two roof vent fixers 6056 on each sill bar 7294 using screws 1006 (4b.5) (4b.6).

Roof Middle Bars

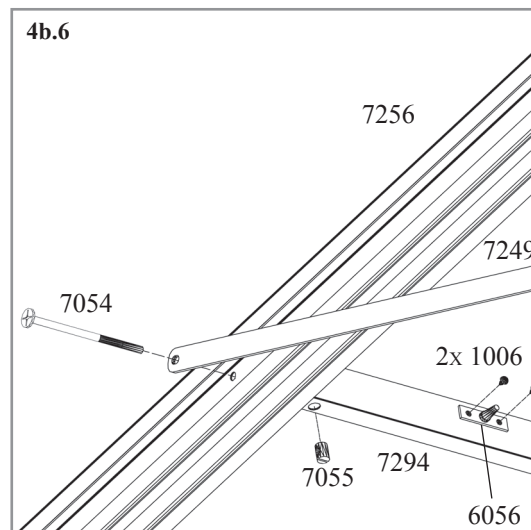
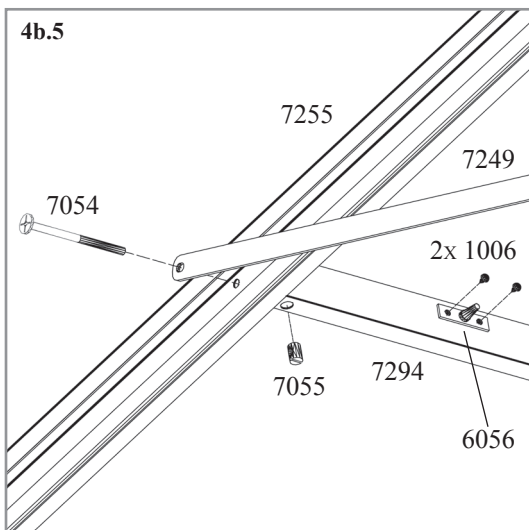
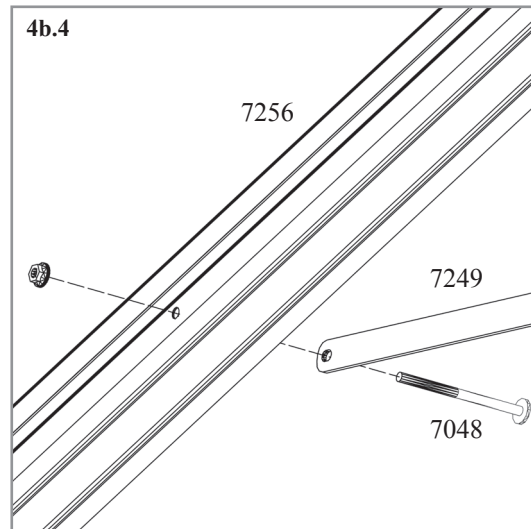
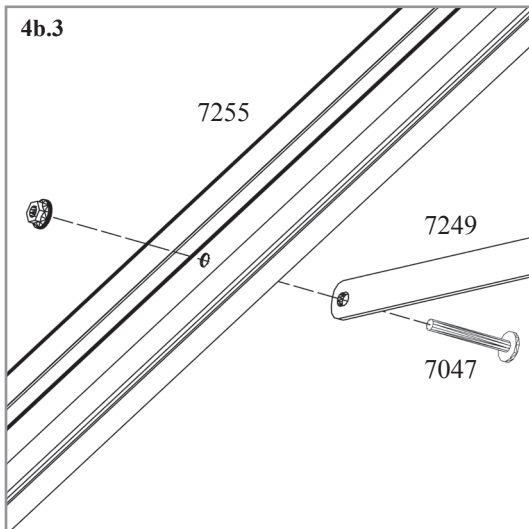

⑤

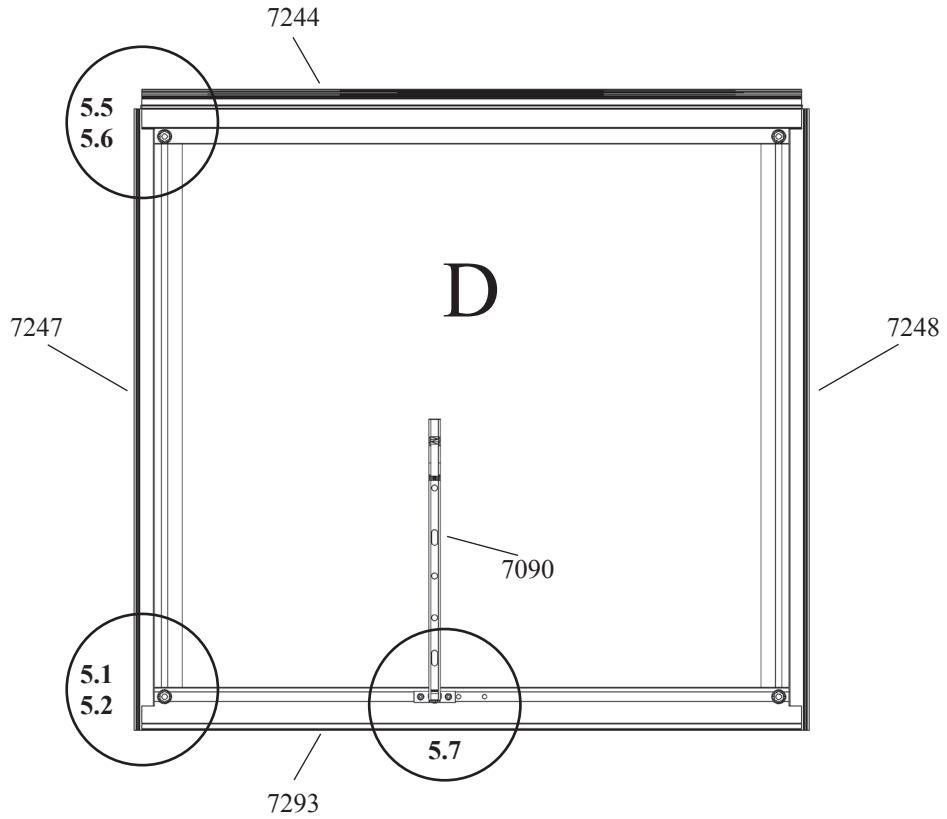

5.1	POLYCARBONATE				QUANTITY / MODEL				
	10 MM		16 MM		8100	10000	11900	13800	15700
	ART. NO.	MM	ART. NO.	MM					
D	3695744	670 x 660	3695745	645 x 637	2x1	2x1	3x1	3x1	3x1

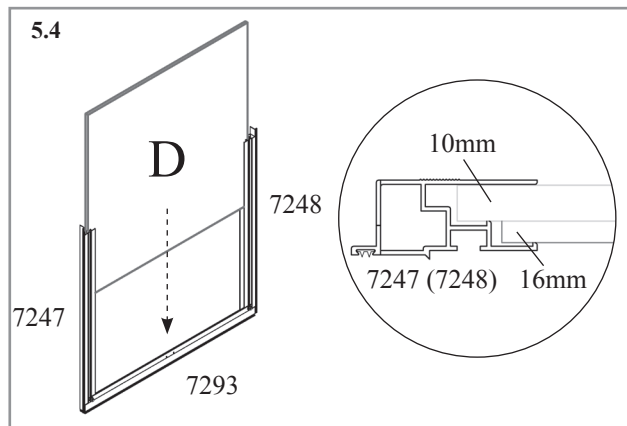
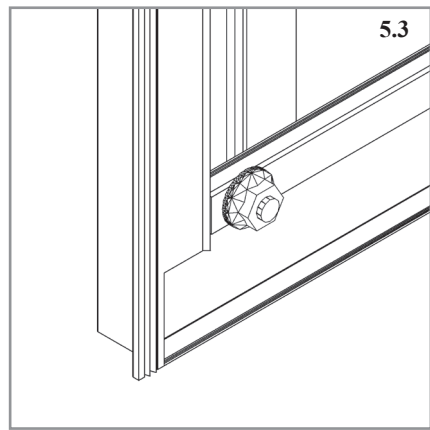
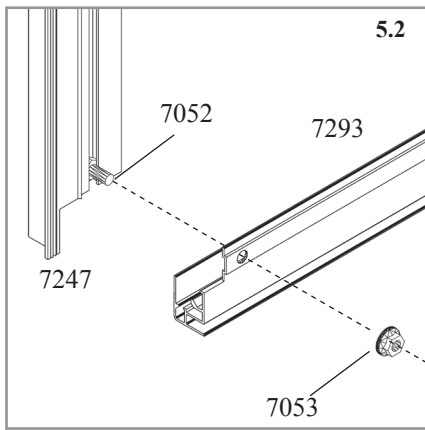

ZEUS 2

ROOF VENTS

PLEASE NOTE ...

With the assembly of the roof vent the glazing must be inserted before the connection of hinge bar 7244.

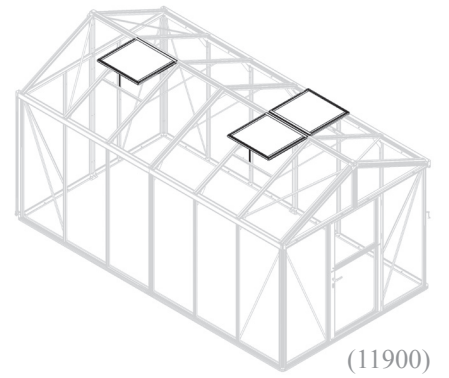

Connect roof vent bottom bar 7293 with side bars 7247 and 7248 using bolts 7052 and nuts 7053, as shown in ⑤ (5.2) (5.3).

Insert the appropriate glazing pane, see table 5.1, into the glazing channels in the assembled parts (5.4).

Prepare roof vent hinge bar 7244 by loosely inserting bolts 7052 and nuts 7053 at both ends (5.5). Insert the head of both 7052 into the bolt channels in 7247 and 7248 fitting the glazing into the glazing channels in 7244 (5.5) (5.6).

Check that the roof vent is right angular before tightening all bolts. **Please do not over tighten.**

Connect roof vent lifter 7090 to the roof vent bottom bar 7293 using two screws 1006 (5.7).

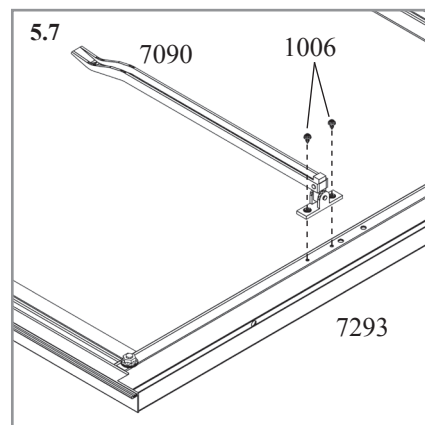
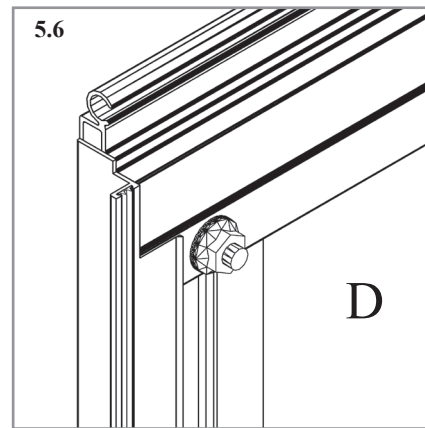
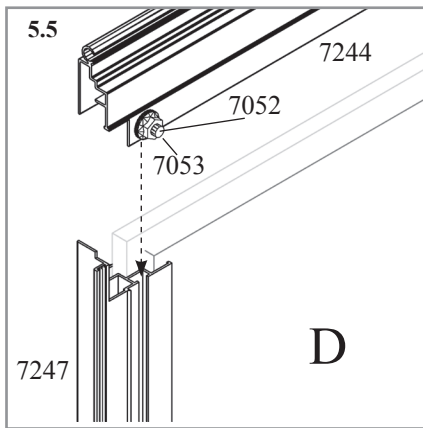

UPPER DOOR

PLEASE NOTE ...

The glazing panes will be assembled in the doors in Section 7c.

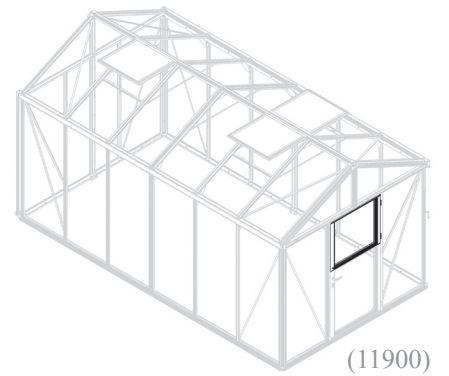

Assemble the side bars 7017 and 7018 with the horizontal bars 7022 as shown in ©a. To connect the vertical bars to the horizontal bars insert cross dowels 7055 in the prepared holes in bars 7022 and pass bolts 7054 through the side bars (6a.1) (6a.2).

Note the prepared holes to connect latch 7085. Connect bottom cover 7024 at this end using six screws 1006 (6a.3).

Include one extra bolt 7052 in the bolt channel of both door side bars 7017 and 7018. Connect top cover 7025 using the prepared bolts, door braces 7114 and four screws 1006 (6a.4).

Slide door seal 7083 into the channel in top cover 7025 (6a.5).

Connect door latch 7085 using screws 7087 to side bar 7018 (6a.6).

Connect door hinges to side bar 7017 using screws 7088 (6a.7).

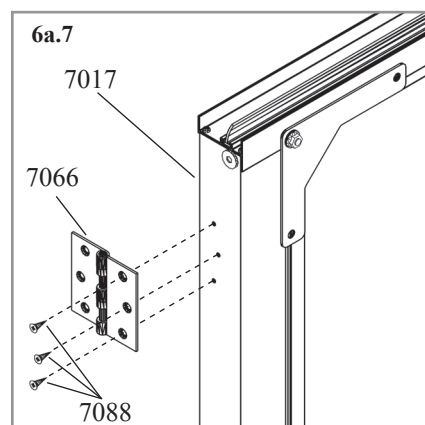
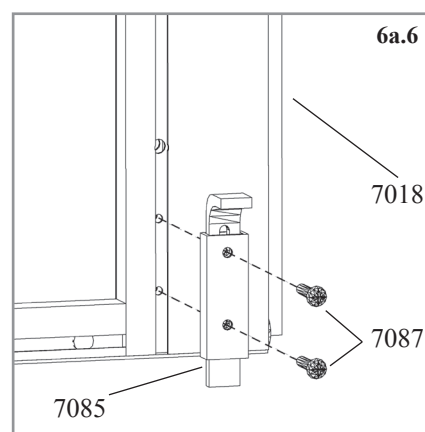
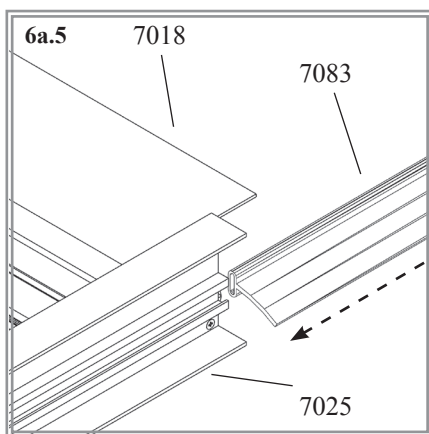

6b

⑥b

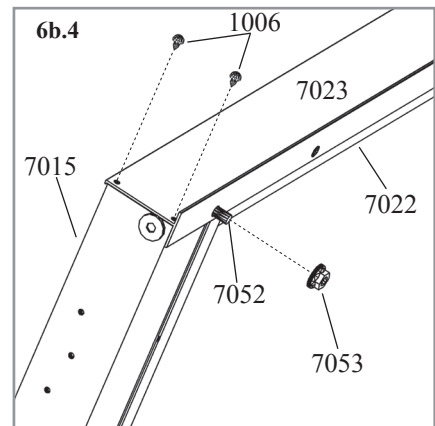
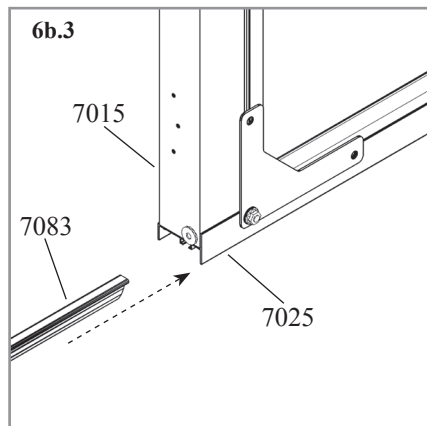
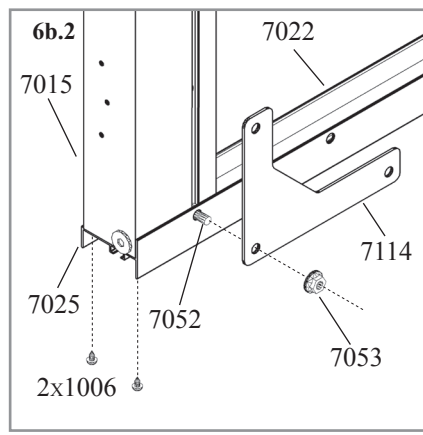
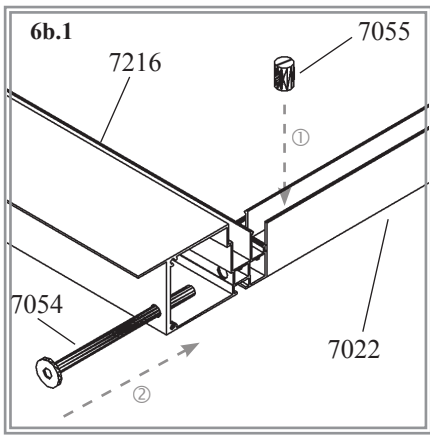
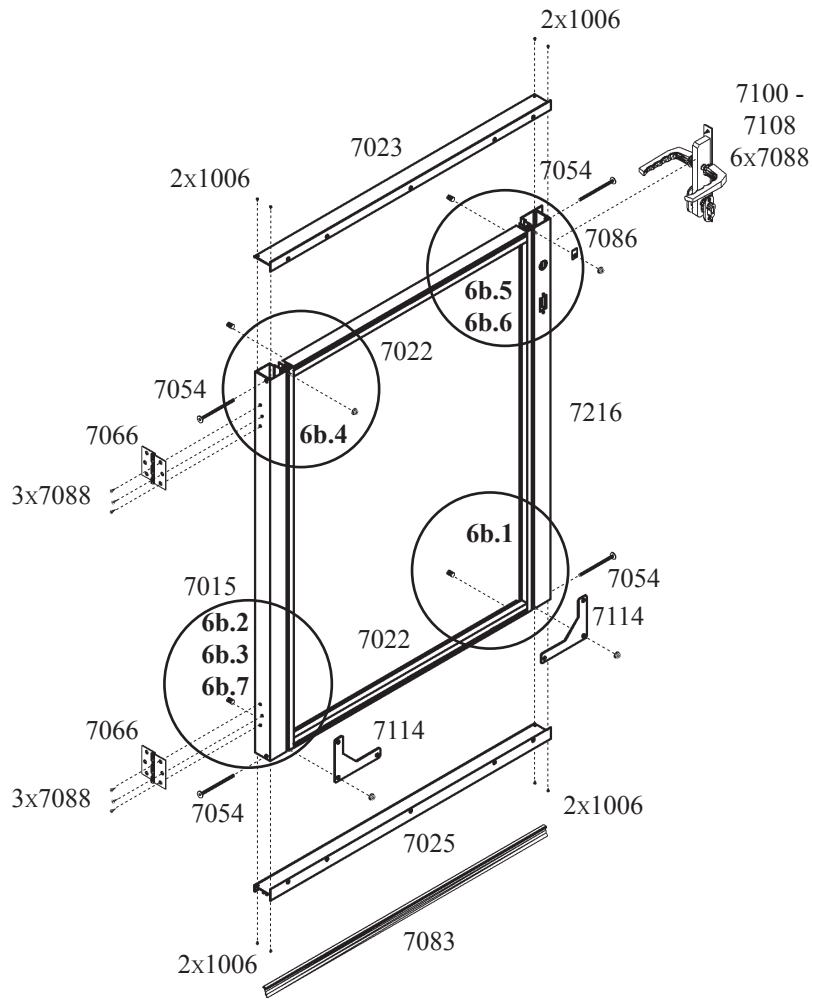

ZEUS 2

LOWER DOOR

PLEASE NOTE ...

The glazing panes will be assembled in the doors in Section 7c.

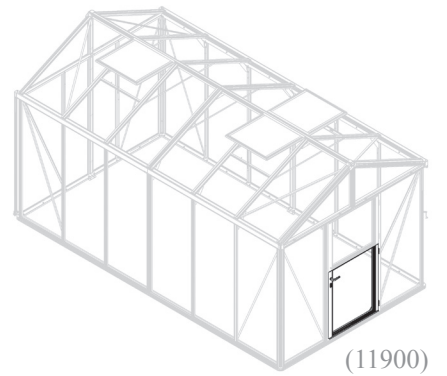

Assemble the side bars 7015 and 7216 with the horizontal bars 7022 as shown in ©b. To connect the vertical bars to the horizontal bars insert cross dowels 7055 in the prepared holes in bars 7022 and pass bolts 7054 through the side bars (6b.1) (6b.2).

Include two extra bolts 7052 in the bolt channel of both door side bars 7015 and 7216 (6b.2) (6b.4) (6b.5).

Connect bottom cover 7025 using the prepared bolts, door braces 7114 and four screws 1006 (6b.2).







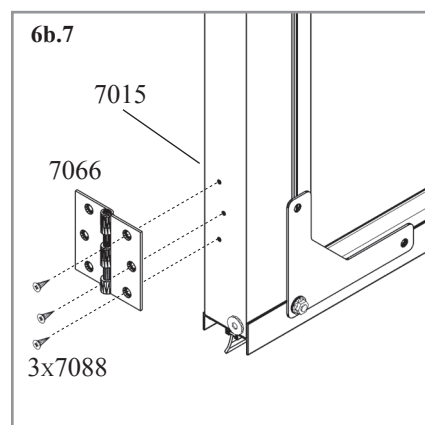
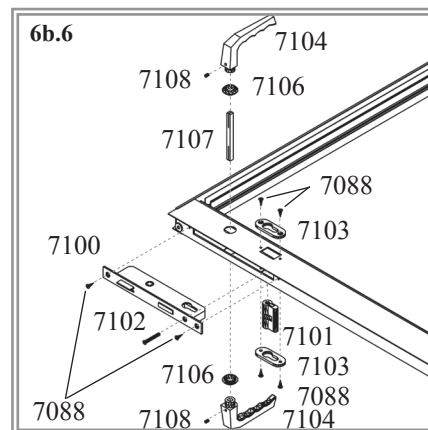
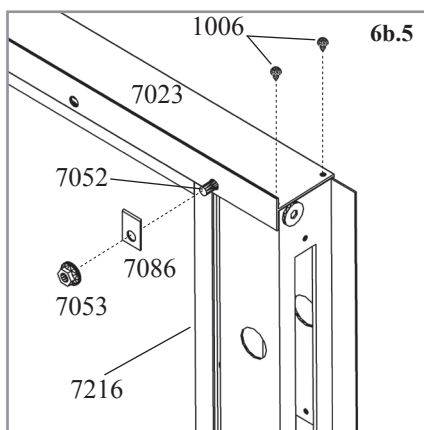

Slide door seal 7083 into the channel in bottom cover 7025 (6b.3).









Connect top cover 7023 using the prepared bolts 7052 and four screws 1006. Additionally connect door latch plate 7086 to side bar 7216 and cover 7023 and fix with nut 7053 (6b.5).

Assemble the door lock 7100 to 7108 using screws 7088 (6b.6).

Connect door hinges 7066 to side bar 7015 using screws 7088 (6b.7).



7.1	POLYCARBONATE						QUANTITY / MODEL				
	6 MM (ROOF 10MM)		10 MM		16 MM		8100	10000	11900	13800	15700
	ART. No.	MM	ART. No.	MM	ART. No.	MM					
A 	3695711	725 x 1790	3695712	725 x 1790	3695713	725 x 1790	12	14	16	18	20
B 	3695726	725 x 1368	3695726	725 x 1368	3695727	710 x 1368	6	8	9	11	13
C 	3695736	725 x 699	3695736	725 x 699	3695737	710 x 691	2	2	3	3	3
D 	3695744	670 x 660	3695744	670 x 660	3695745	645 x 637	2	2	3	3	3
E 	3695751	725 x 966	3695752	725 x 966	3695753	725 x 966	1	1	1	1	1
F 	3695761	725 x 683	3695762	725 x 683	3695763	725 x 683	1	1	1	1	1
G 	3695771	1190x567/15	3695772	1190x567/15	3695773	1190x567/15	2	2	2	2	2
H 	3695781	1190x567/15	3695782	1190x567/15	3695783	1190x567/15	2	2	2	2	2
J 	3695791	435 x 1790	3695792	435 x 1790	3695793	435 x 1790	2	2	2	2	2
TOTAL							30	34	39	43	47

7.2	GLASS / POLYCARBONATE		QUANTITY / MODEL				
	4 MM / 10MM		8100	10000	11900	13800	15700
	ART. No.	MM					
A 	367801	725 x 1790	12	14	16	18	20
B 	3695726	725 x 1368 x 10	6	8	9	11	13
C 	3695736	725 x 699 x 10	2	2	3	3	3
D 	3695744	670 x 660 x 10	2	2	3	3	3
E 	367805	725 x 966	1	1	1	1	1
F 	367806	725 x 683	1	1	1	1	1
G 	367807	1190x567/15	2	2	2	2	2
H 	367808	1190x567/15	2	2	2	2	2
J 	367809	435 x 1790	2	2	2	2	2
TOTAL			30	34	39	43	47

GLAZING PLAN

PLEASE NOTE ...

The following steps will require 2 to 3 people to assemble.

Always wear protective glasses, gloves, shoes and headgear when assembling the glazing.

Assemble the panes in the order 7a - 7b - 7c as shown.

The outside surface of the polycarbonate panes is identified by a plastic film and / or printing at the edge.

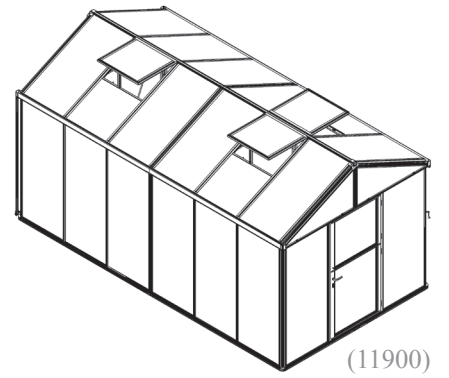

Please sort the glazing according to your model size and glazing type, tables 7.1 or 7.2, before beginning.



The UV-resistant side of the polycarbonate panes is indicated by a plastic film and / or printing at the edge. This side must face outside. Loosen the film approximately 2cm at all edges of each pane before assembly. When the assembly of all panes is finished completely remove all film from the panes.

Model				
8100	10000	11900	13800	15700
A				<input type="checkbox"/>
12	14	16	18	20
B				<input type="checkbox"/>
6	8	9	11	13
C				<input type="checkbox"/>
2	2	3	3	3
E				<input type="checkbox"/>
1	1	1	1	1
F				<input type="checkbox"/>
1	1	1	1	1
G				<input type="checkbox"/>
2	2	2	2	2
H				<input type="checkbox"/>
2	2	2	2	2
J				<input type="checkbox"/>
2	2	2	2	2

(8100)

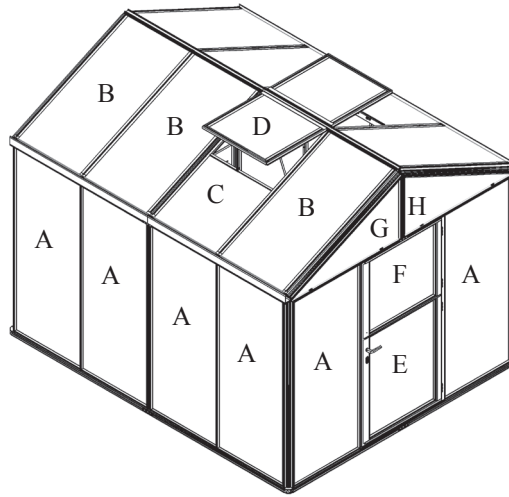

(10000)

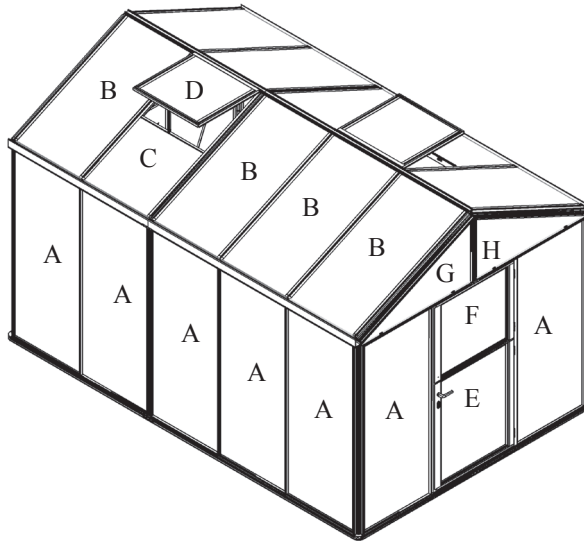

(11900)

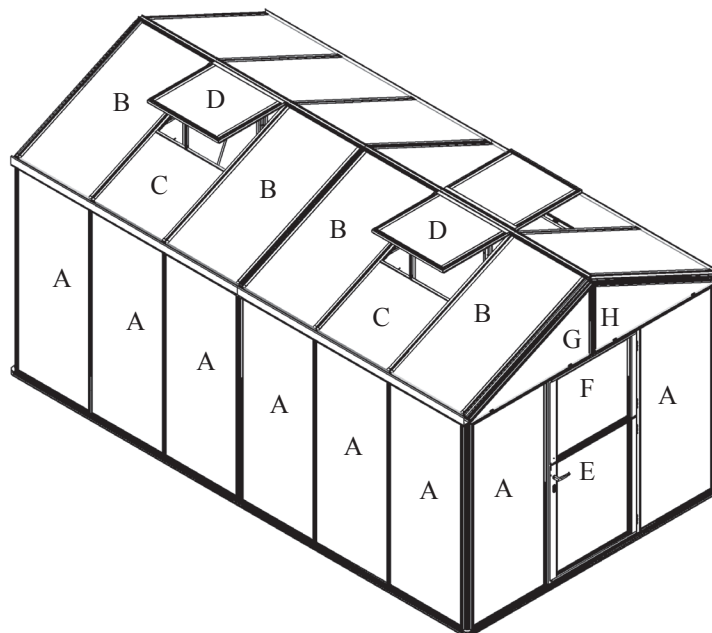

(13800)

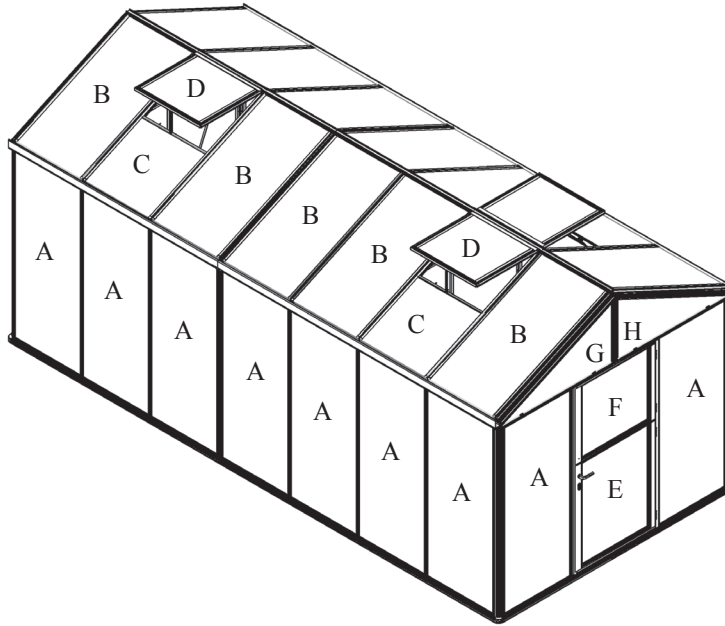

(15700)

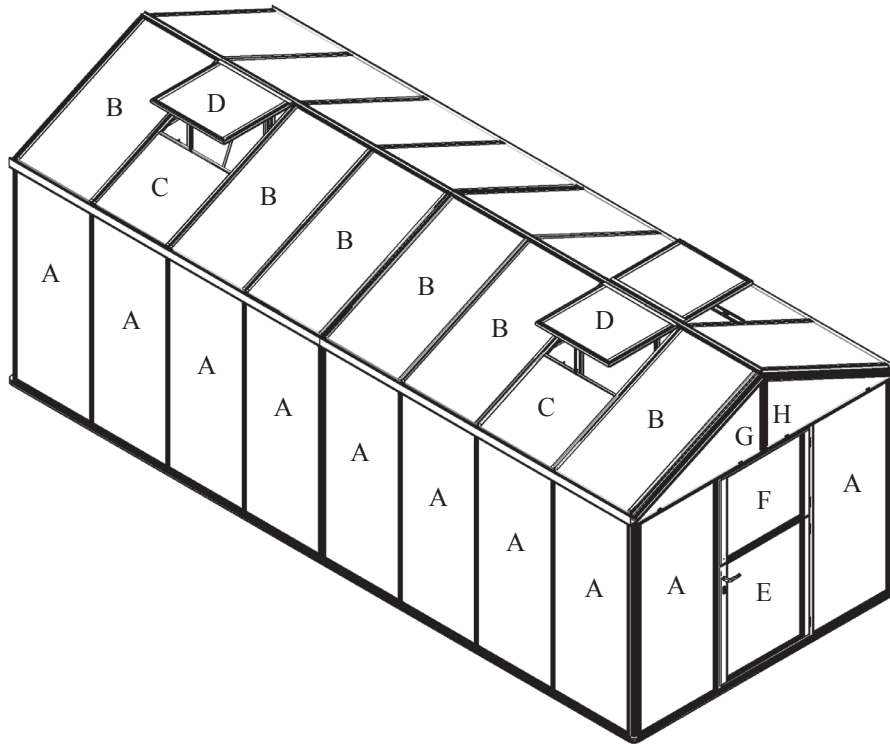

Back Gabel - all models

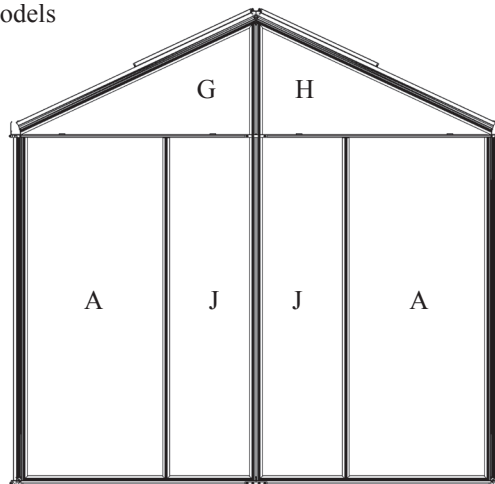

7a

(10000)

7a.1	EAVE 1-EAVE 2	LÄNGE
8100	7213-7213	1539 + 1539 mm
10000	7213-7214	1539 + 2283 mm
11900	7214-7214	2283 + 2283 mm
13800	7214-7215	2283 + 3027 mm
15700	7215-7215	3027 + 3027 mm

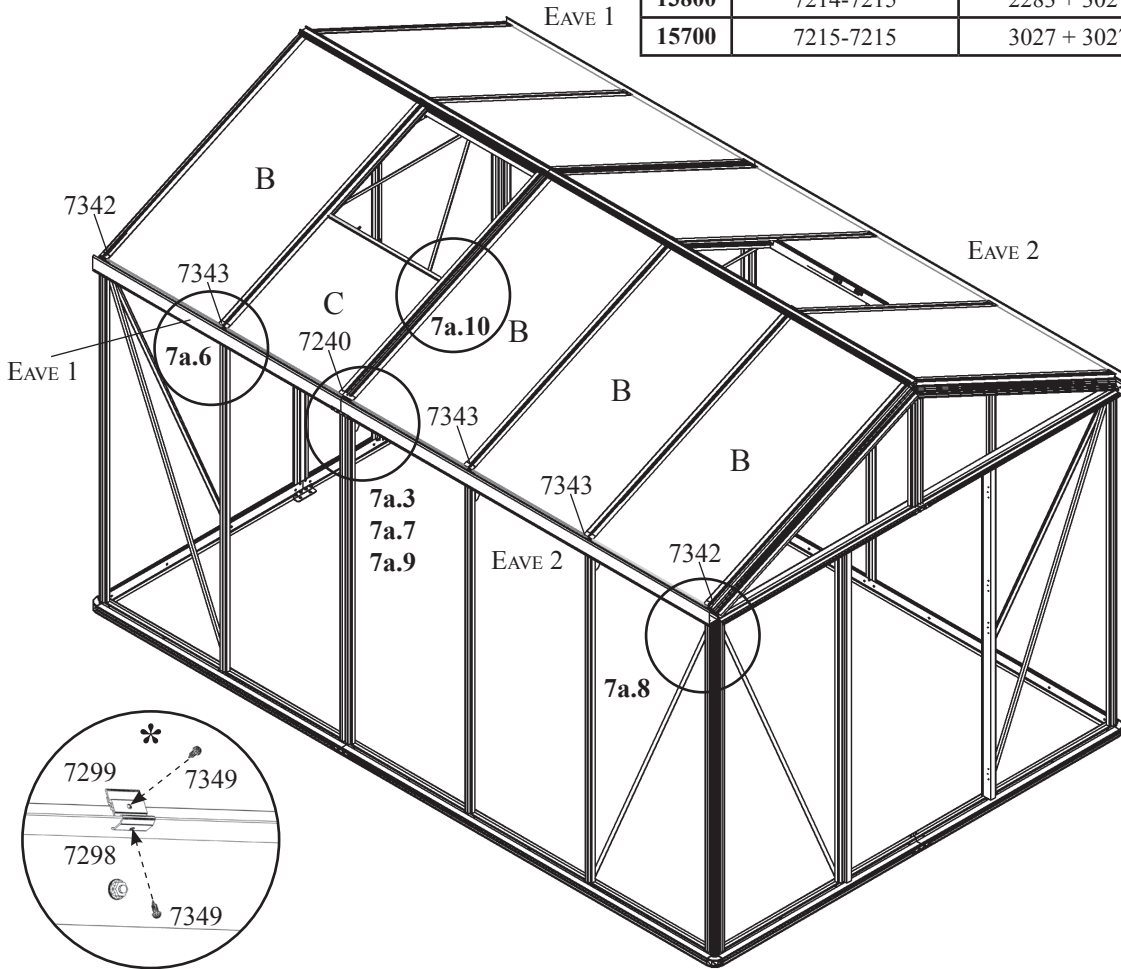

Model				
8100	10000	11900	13800	15700
7052				
8	10	12	14	16
7053				
8	10	12	14	16
7061				
2	2	2	2	2
7064				
2	2	2	2	2
7080				
8	8	8	8	8
7213				
4	2	0	0	0
7214				
0	2	4	2	0
7215				
0	0	0	2	4
7240				
2	2	2	2	2
7292				
2	2	2	2	2
7296				
8	10	12	14	16
7297				
8	10	12	14	16
7342				
4	4	4	4	4
7343				
4	6	8	10	12
7349				
34	42	50	58	66
7298*				
8	10	12	14	16
7299*				
8	10	12	14	16

7a.2	POLYCARBONATE				QUANTITY / MODEL				
	10 MM		16 MM		8100	10000	11900	13800	15700
	ART. NO.	MM	ART. NO.	MM					
B	3695726	725 x 1368	3695727	710 x 1368	6	8	9	11	13
C	3695736	725 x 699	3695737	710 x 691	2	2	3	3	3

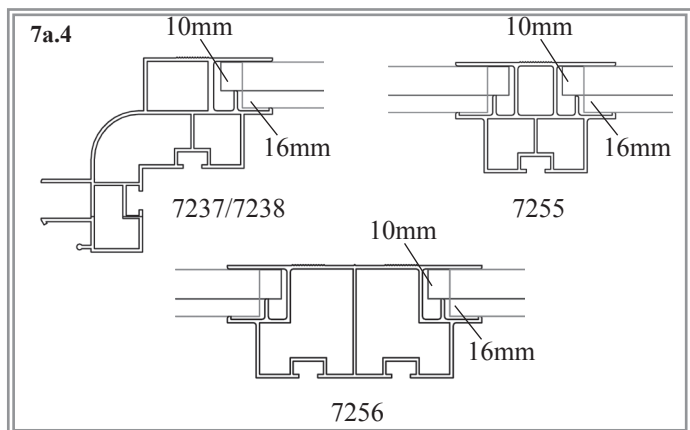
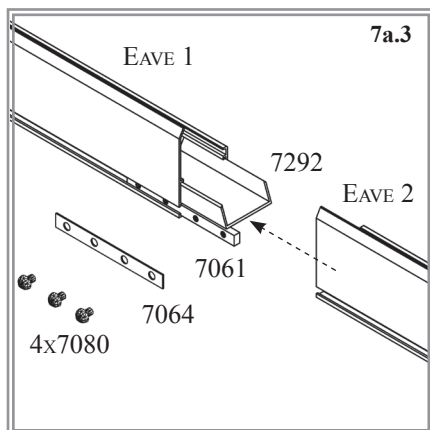

GLAZING ROOF / EAVE

PLEASE NOTE ...

This step will require 2 to 3 people to assemble.

Always wear protective glasses, gloves, shoes and headgear when assembling the glazing.

The outside surface of the polycarbonate panes is identified by a plastic film and / or printing at the edge.

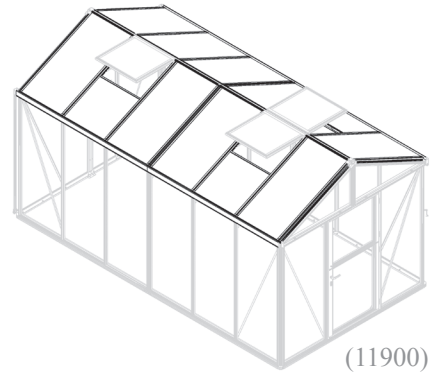

(11900)

Assemble the eave bars according to table 7a.1. Connect them by sliding connecting block 7061 into the channels in the eave bars and fix them in place using plates 7064 and screws 7080. Ensure join plastic 7292 is centered at the join (7a.3).

Slide the roof glazing into the guides in the roof profiles (7a.4). When two adjacent panes are in place, screw glazing stops 7240, 7342 or 7343 onto the roof profile between them using the prepared holes and self drilling screws 7349 (7a.6). The panes should slide down to rest against these stops.

Insert glazing spacers 7296 over the inside edge of the eave angle (7a.7). If you have 10mm glazing then position spacer 7297 into the groove in 7296, resting against the pane. Fix in place using the prepared holes and screws 7349 (7a.7) (7a.9a). 16mm glazing does not require spacer 7297 (7a.9b).

In the roof vent sections slide glazing pane C into the guides in profile 7294 (7a.10).

Angle the eave bar assembly into the eave angle (7a.8) and turn it down to rest against the eave angle. Connect it to the eave angle using bolts 7052 from outside and nuts 7053 inside the house (7a.9).

** The formation of condensation is unavoidable in a greenhouse with polycarbonate plates, however it may be reduced by exchanging the parts (7296 / 7297) with (7298 / 7299). This will allow increased ventilation inside and thereby reduce the condensation. Please fix (7298 / 7299) in the middle of each field at the eave using screws (7349).*

Glazing Roof / Eave

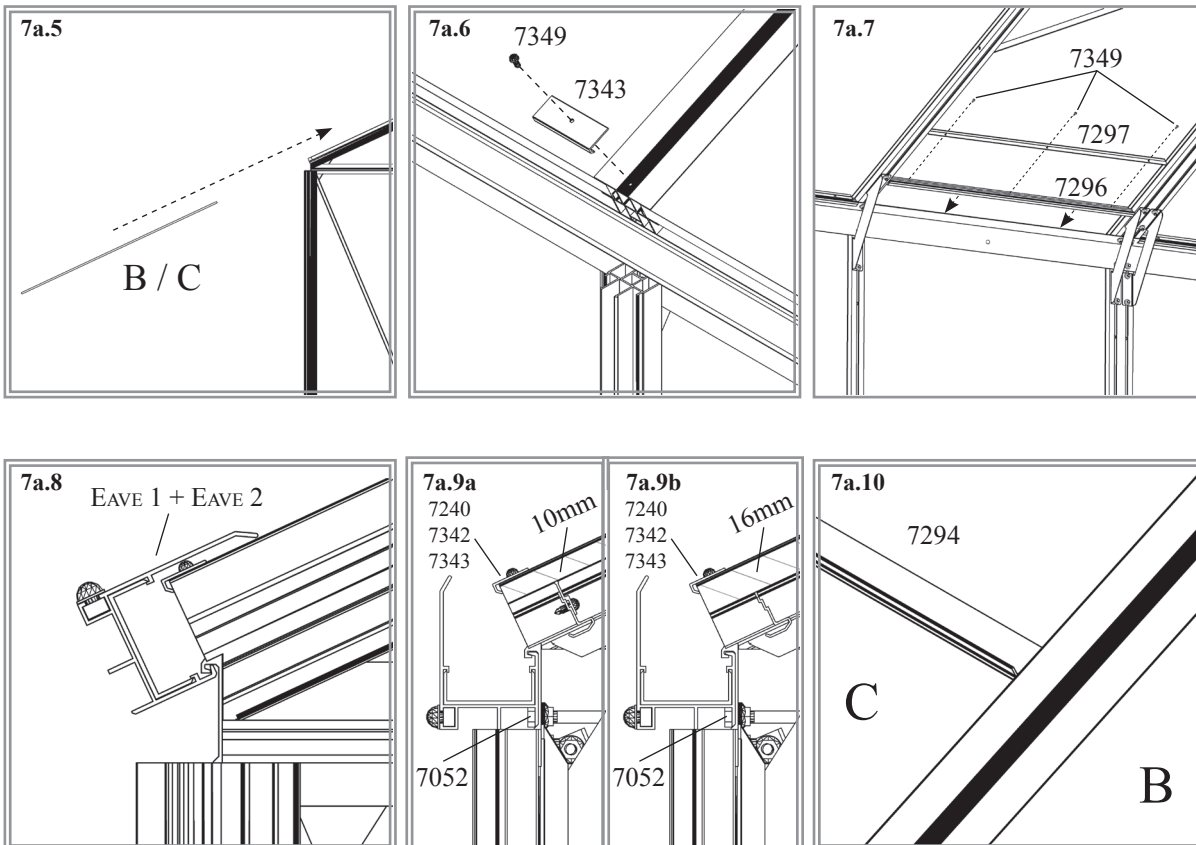

7b

(10000)

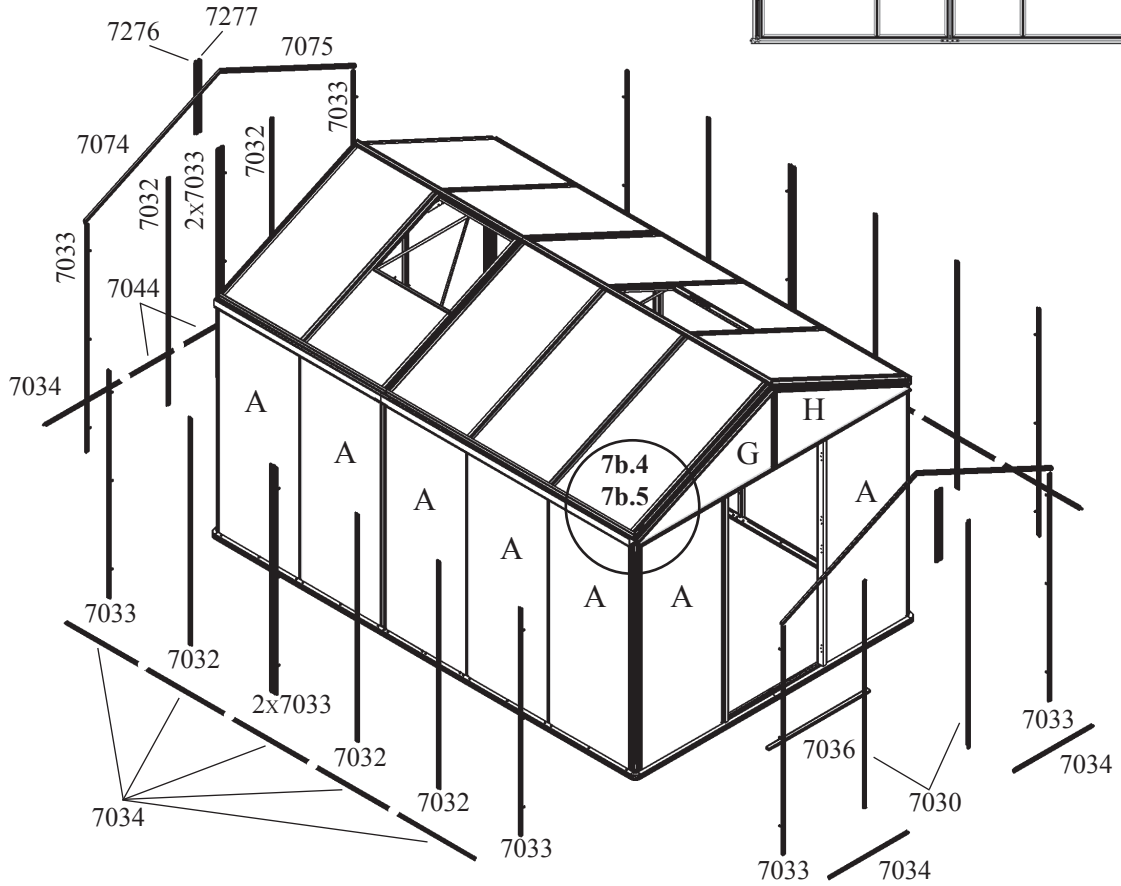
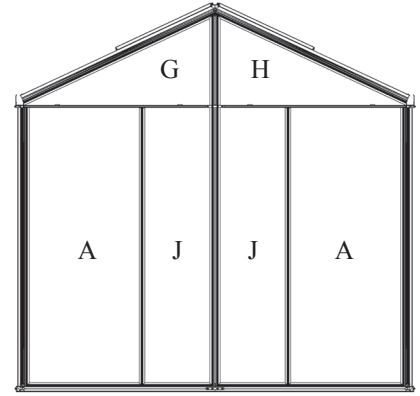
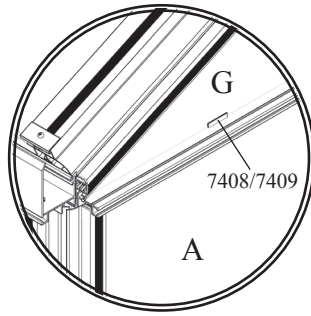

Model				
8100	10000	11900	13800	15700
6090				
1	1	1	1	1
7030				
2	2	2	2	2
7032				
6	8	10	12	14
7033				
14	14	14	14	14
7034				
12	14	16	18	20
7036				
1	1	1	1	1
7044				
2	2	2	2	2
7050				
126	138	150	162	174
7053				
130	142	154	166	178
7074				
2	2	2	2	2
7075				
2	2	2	2	2
7276				
2	2	2	2	2
7277				
2	2	2	2	2
7390				
4	4	4	4	4
7406				
14	16	18	20	22
7407				
14	16	18	20	22
7408				
8	8	8	8	8
7409				
8	8	8	8	8

7b.1	GLASS	POLYCARBONATE				MM	QUANTITY / MODEL				
		4 MM	6 MM	10 MM	16 MM		8100	10000	11900	13800	15700
		ART. No.	ART. No.	ART. No.	ART. No.						
A		367801	3695711	3695712	3695713	725 x 1790	12	14	16	18	20
G		367807	3695771	3695772	3695773	1190x567/15	2	2	2	2	2
H		367808	3695781	3695782	3695783	1190x567/15	2	2	2	2	2
J		367809	3695791	3695792	3695793	435 x 1790	2	2	2	2	2

GLAZING SIDE

PLEASE NOTE ...

This step will require 2 to 3 people to assemble.

Always wear protective glasses, gloves, shoes and headgear when assembling the glazing.

The outside surface of the polycarbonate panes is identified by a plastic film and / or printing at the edge.

For 4mm glass the glazing rubber 6090 is required. With Polycarbonate the glazing rubber is not required.

Spacers 7406-7409 are not required with glass or 16mm glazing.

Begin by preparing the four bolts 7390 in the door sill bar 7036. Connect 7036 into sill bars 7003 and 7004, from the outside, in the door opening.

If glazing with 4mm glass, press glazing rubber 6090 onto the aluminium profiles (7b.2) and cut to length.

Through the positioning of the 7050 bolt head in the different guides in the glazing cappings, it is possible to glaze the greenhouse with 4mm, 6mm, 10mm or 16mm panes (7b.2).

Prepare 3 bolts 7050 in each glazing capping as shown (7b.3). Cappings 7044 require only 2 bolts 7050.

Prepare 1 spacer, (6mm 7406 / 10mm 7407), in the middle / top of pane A or J (7b.4). Position each glazing pane A or J into the frame and connect the vertical cappings loosely with nuts 7053. Lift the pane 15mm and connect cappings 7034 or 7044 loosely under the pane.

Prepare 2 spacers, (6mm 7408 / 10mm 7409), onto each 7010 and 7011 (7b.5). Position panes G and H onto the spacers and connect cappings 7074, 7075, 7276 and 7277 loosely.

Check that the greenhouse is completely right angular before tightening all bolts. **Please do not over tighten.**



The vertical cappings can be best assembled when the bottom bolt is first inserted into the hole, then the middle and finally the top bolt. Ensure that the capping remains in contact with the sill bar.

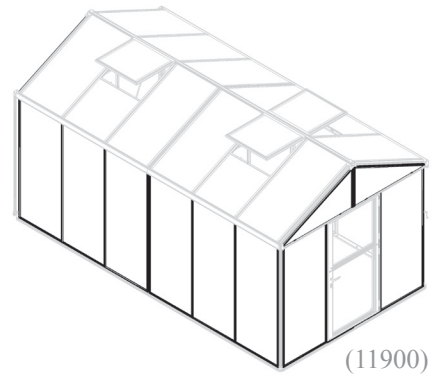

(11900)

Glazing Side

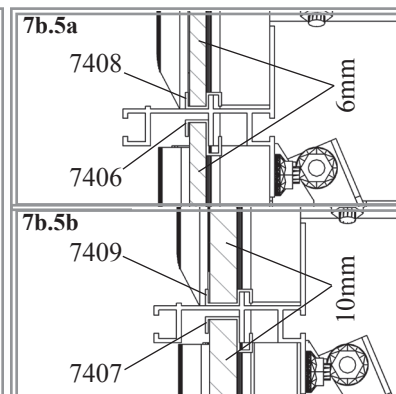
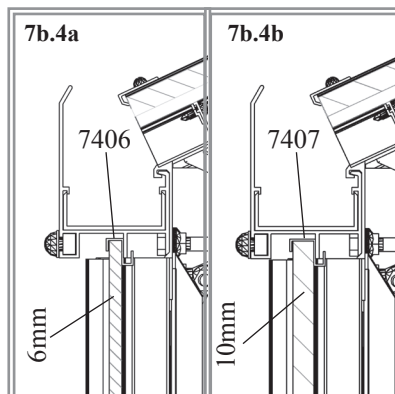
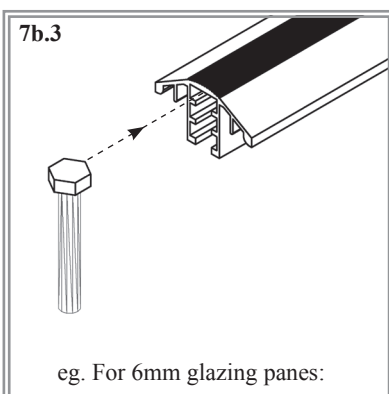
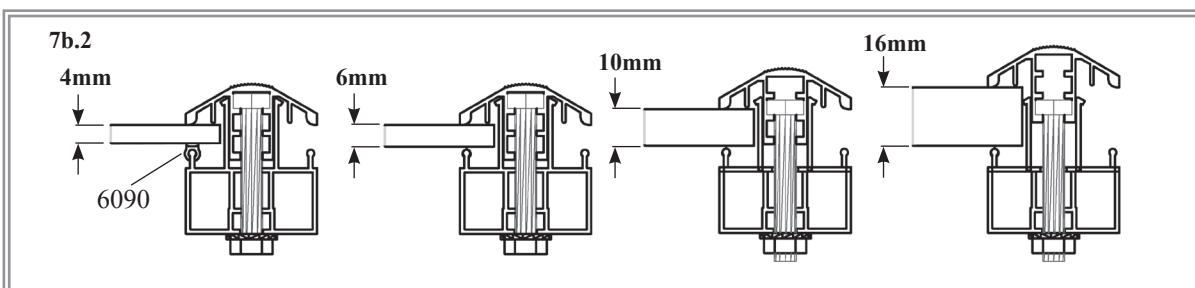

7c

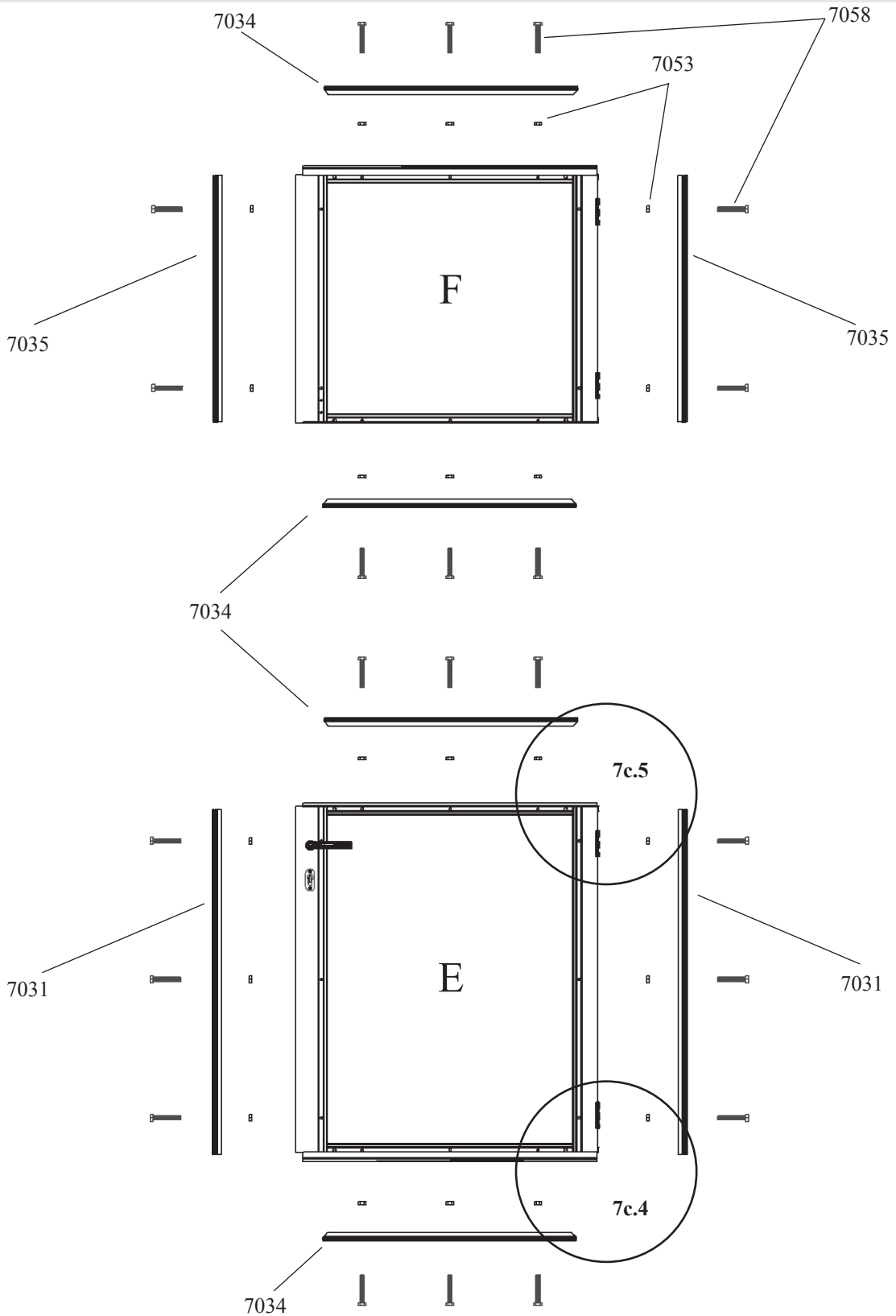

All Models	
6090 x1	
7031 x2	
7034 x4	
7035 x2	
7053 x22	
7058 x22	
E x1	
F x1	

7c.1	GLASS	POLYCARBONATE				QUANTITY / MODEL				
	4 MM	6 MM	10 MM	16 MM	MM	8100	10000	11900	13800	15700
	ART. No.	ART. No.	ART. No.	ART. No.		8100	10000	11900	13800	15700
E <input type="checkbox"/>	367805	3695751	3695752	3695753	725 x 966	1	1	1	1	1
F <input type="checkbox"/>	367806	3695761	3695762	3695763	725 x 683	1	1	1	1	1

ZEUS 2

GLAZING DOOR

PLEASE NOTE ...

Always wear protective glasses, gloves, shoes and headgear when assembling the glazing.

The outside surface of the polycarbonate panes is identified by a plastic film and / or printing at the edge.

For 4mm glass the glazing rubber 6090 is required. With Polycarbonate the glazing rubber is not required.

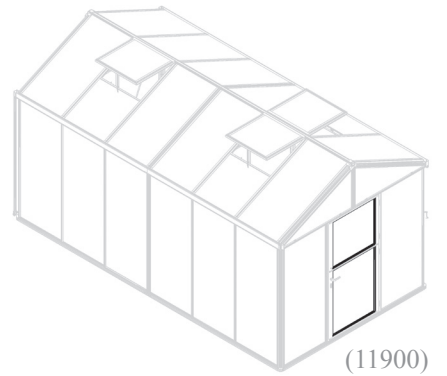

If glazing with 4mm glass, press glazing rubber 6090 onto the aluminium profiles (7c.2) and cut to length.

Through the positioning of the 7058 bolt head in the different guides in the glazing cappings, it is possible to glaze the doors with 4mm, 6mm, 10mm or 16mm panes (7c.2).

Prepare the bolts 7058 in the glazing cappings as shown (7c.3).

Lay the glazing panes into the aluminium frame.

Position the cappings and loosely connect them with nuts 7053.





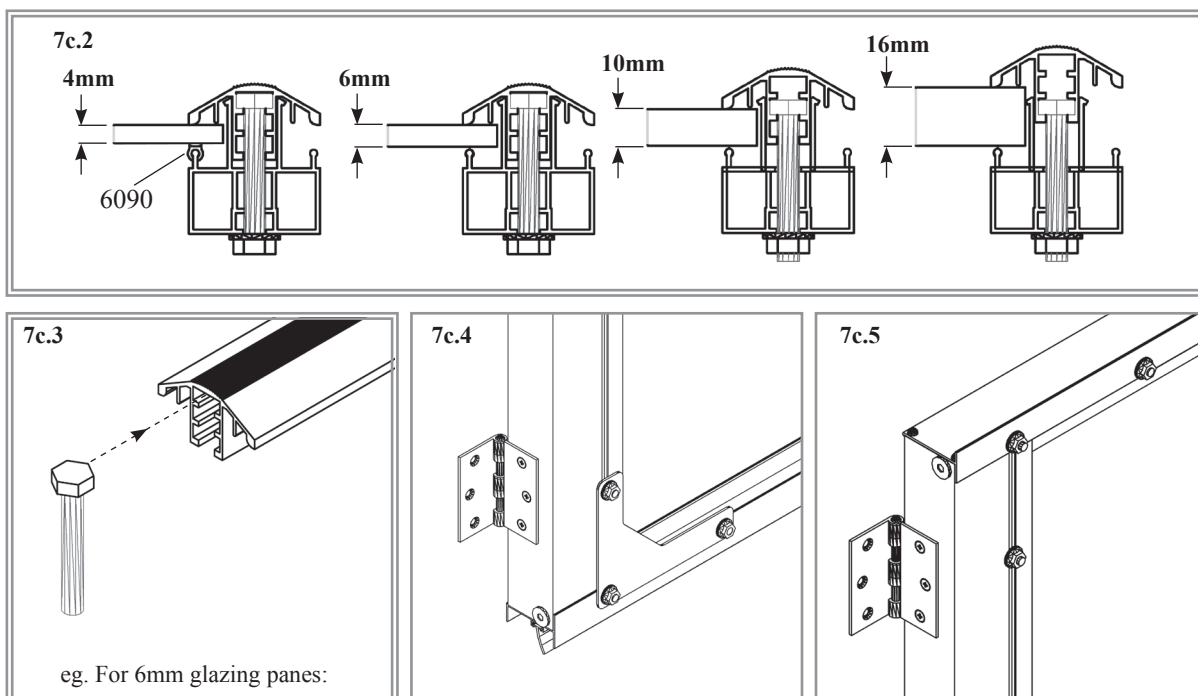



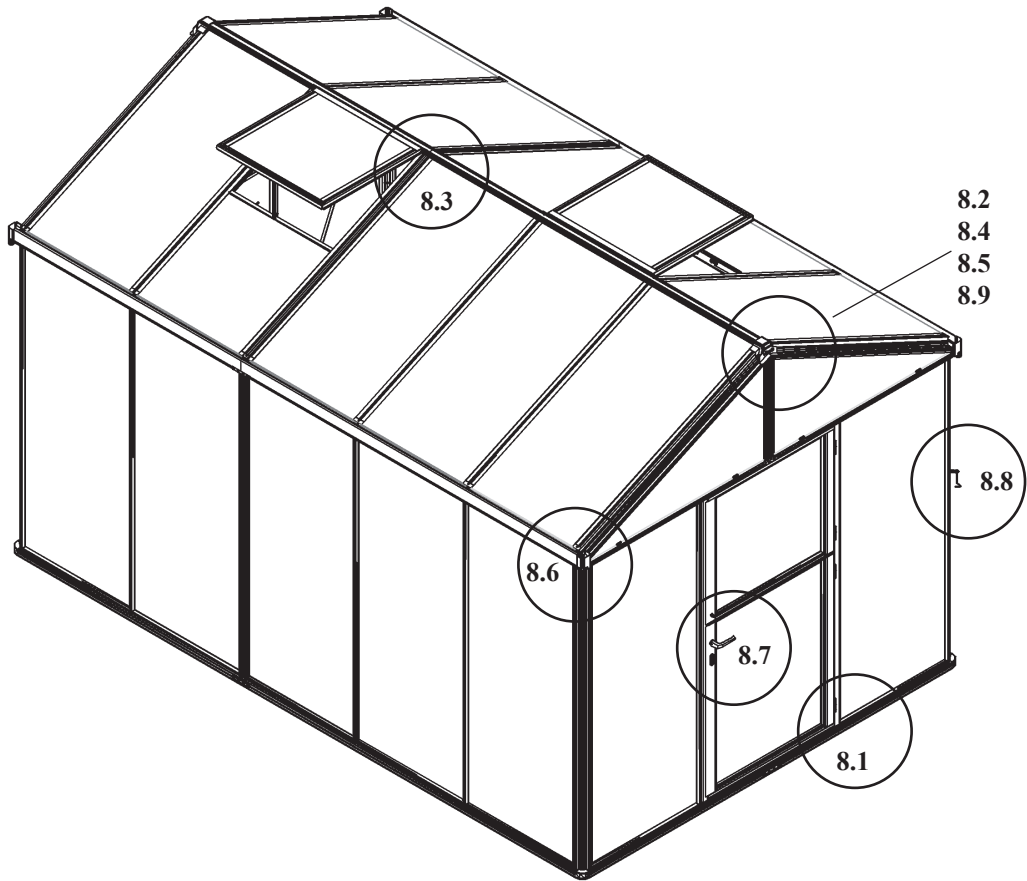



Check that the doors are right angular before tightening all bolts. **Please do not over tighten.**

Glazing Door



(10000)



Model				
8100	10000	11900	13800	15700
7053 				
1	1	1	1	1
7056 				
4	4	4	4	4
7088 				
12	12	12	12	12
7111 				
1	1	1	1	1
7112 				
1	1	1	1	1
7113 				
1	1	1	1	1
7266 				
2	2	2	2	2
7349 				
4	4	6	6	6
7369 				
4	4	6	6	6
7370 				
2	2	2	2	2
7371 				
2	2	2	2	2
7399 				
1	1	1	1	1

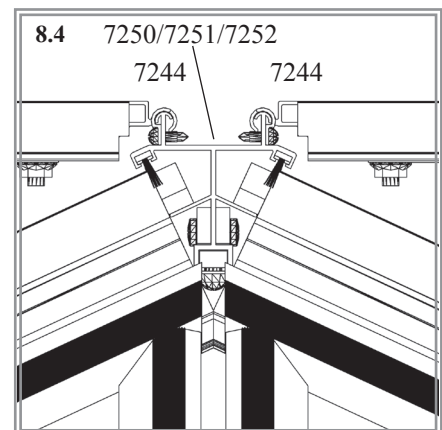
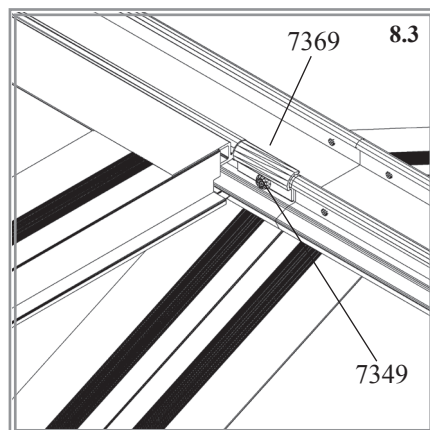
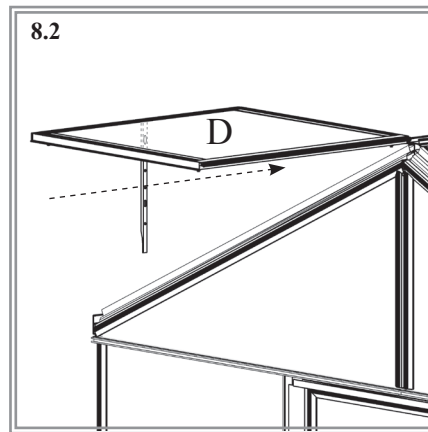
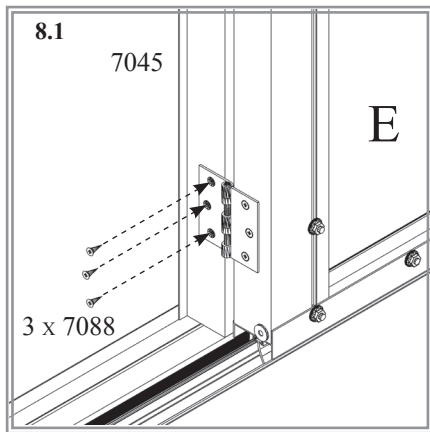

FINISHING

PLEASE NOTE ...

Check that the greenhouse is completely right angular and all nuts tight. Please do not over tighten. This should be repeated after 14 days.

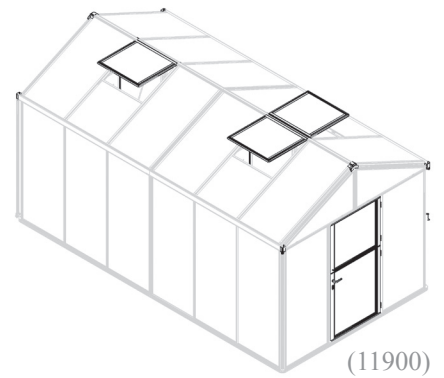

Connect the doors, completed in step 6, to door support 7045 using the prepared holes and screws 7088 (8.1).

Slide the roof vent into the correct section from one end of the house (8.2). Attach the roof vent fixer 7369 using the prepared holes and self drilling screw 7349 on both sides of the roof vent (8.3) (8.4).

Slide ridge end cap 7266 onto both ends. Fix in place using 2 self drilling screws 7056 (8.5). Slide eave plastics 7370 and 7371 into the eave bars 7213, 7214 or 7215 (8.6). *It can help to pull the eave bar 7213, 7214 or 7215 at the top edge, carefully away from the house so that the opening for the plastic becomes larger.*

Assemble door holder 7111 using spacer 7112 onto top door side bar 7018 (8.7).

Insert bolt 7399 into the bolt channel in corner bar 7236. Adjust the height to match door holder 7111 and fix in place with nut 7053. Assemble door latch 7113 onto bolt 7399 (8.8).







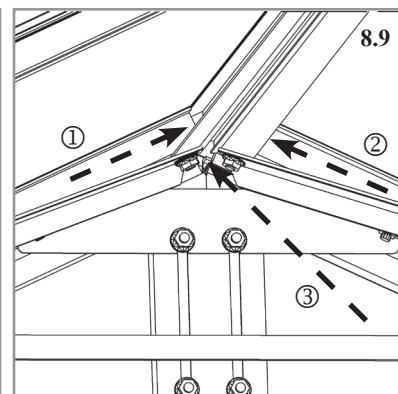
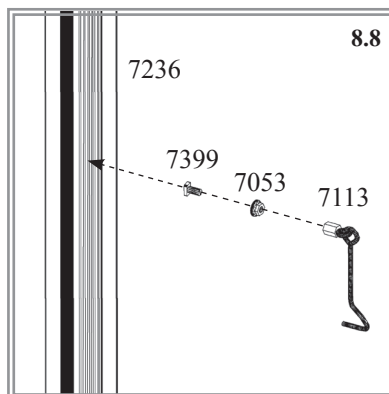
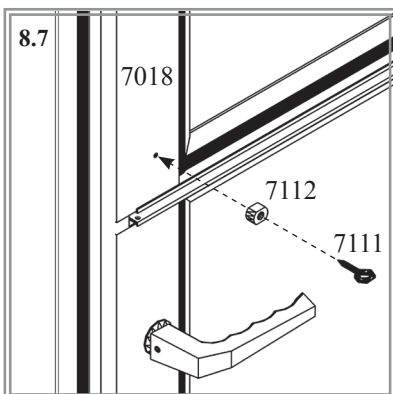
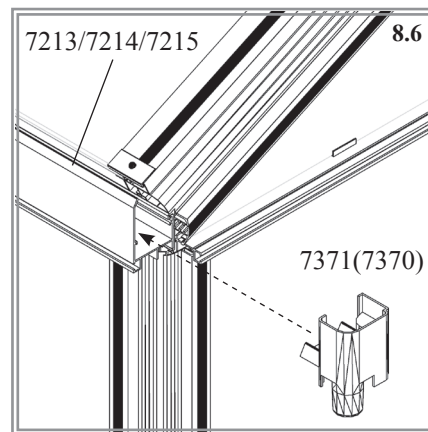
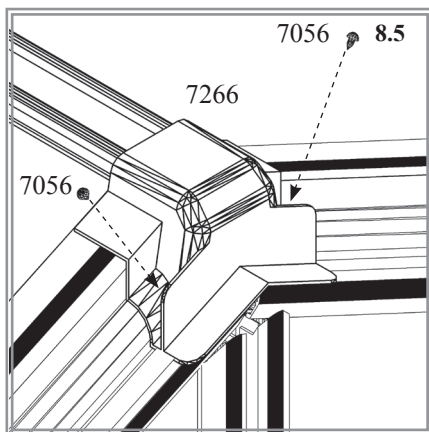

It is recommended to include a bead of neutral silicone along the ridge join from outside and to fill the ridge corners at 3 points from inside (8.9). Neutral silicone is not provided.

Connect sill angles 7095 to the foundation using plugs and bolts (not provided).

Stick the appropriate model label and warning label inside the house for future reference.



All Models

1002 x2	
1006 x2	
1402 x2	
1403 x2	
1405 x2	
1409 x2	
1412 x2	
1415 x2	

(11900)

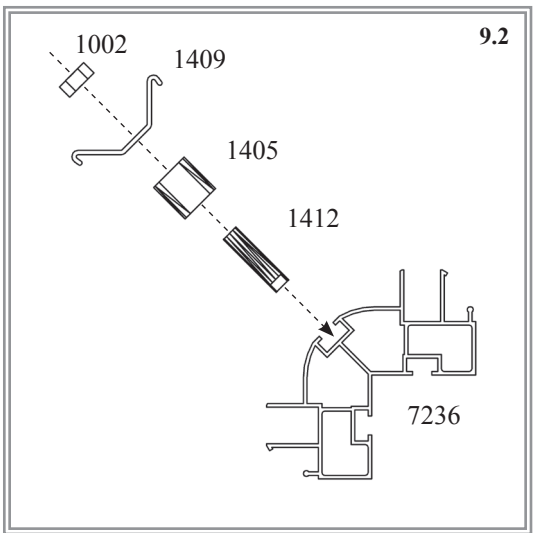
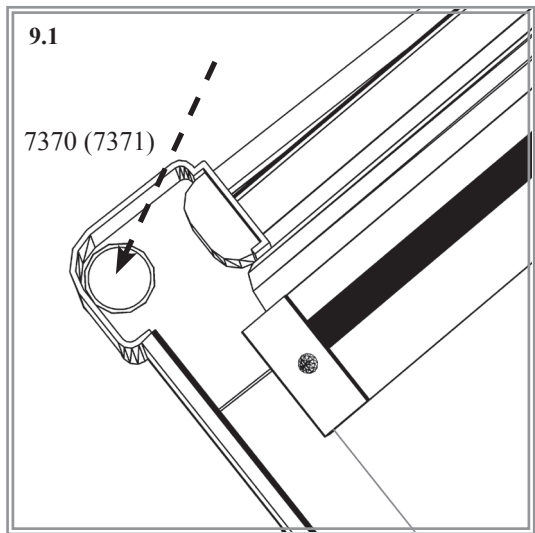
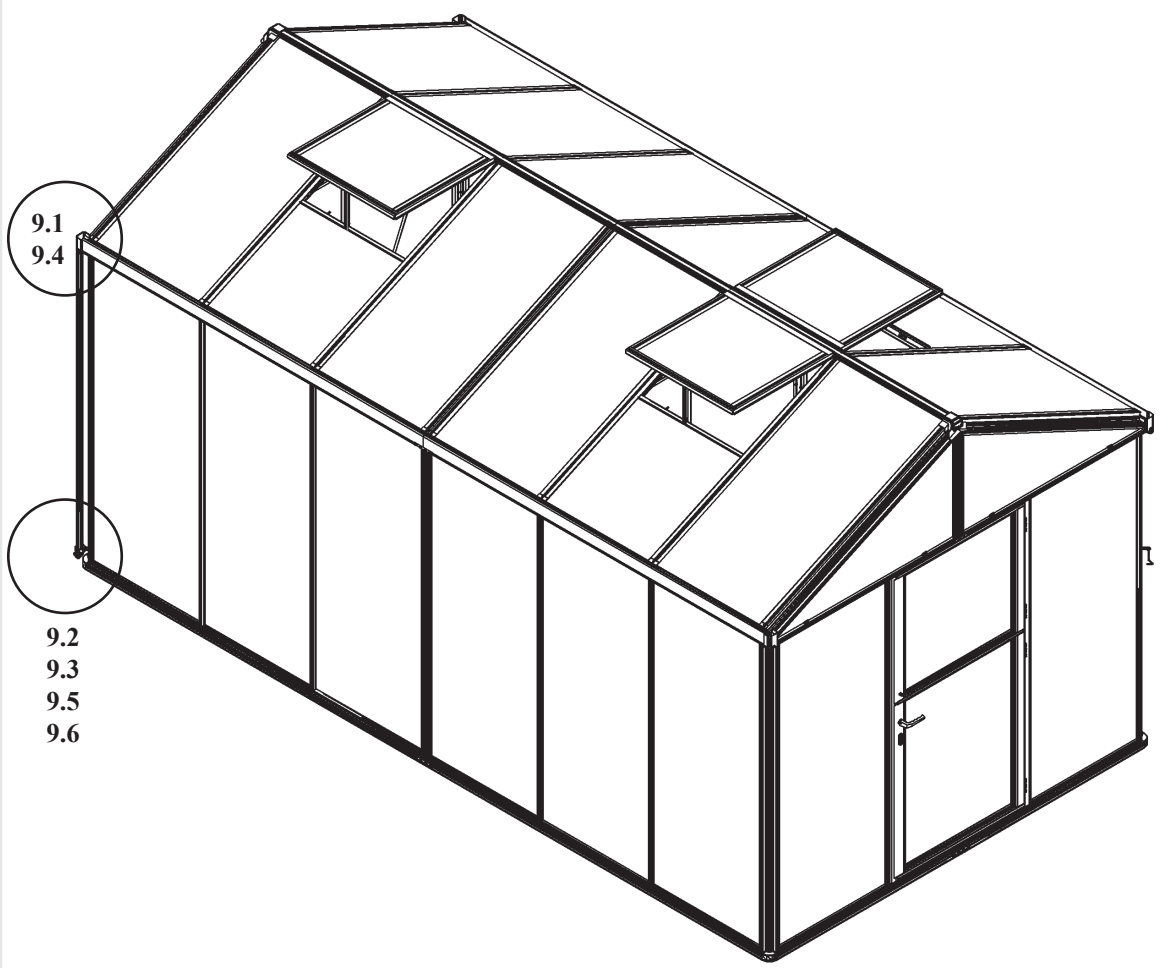

ZEUS 2

DOWN PIPES

PLEASE NOTE ...

Please wear protective glasses and gloves.

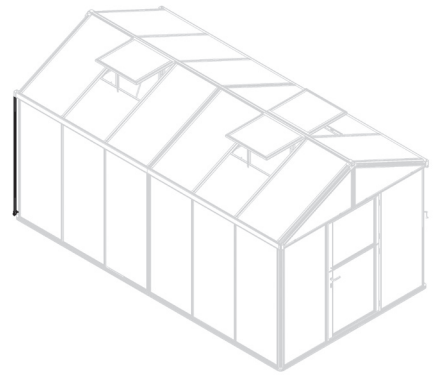

Please take a drill not larger than $\text{Ø } 25\text{mm}$ and make a hole in the marked area inside parts 7370 or 7371 at the rear of the greenhouse (9.1).

Insert bolt 1412 into the bolt channel at the bottom of corner post 7236 and connect parts 1405 and 1409 with nut 1002 on both sides (9.2).

Fit elbow 1402 onto the bottom of down pipe 1415 (9.3) and then connect this to the eave plastic 7370 or 7371 (9.4).

Fit the down pipe clamp 1403 around the down pipe and connect to 1409 (9.5).

Insert screw 1006 to fix the down pipe in place (9.6).

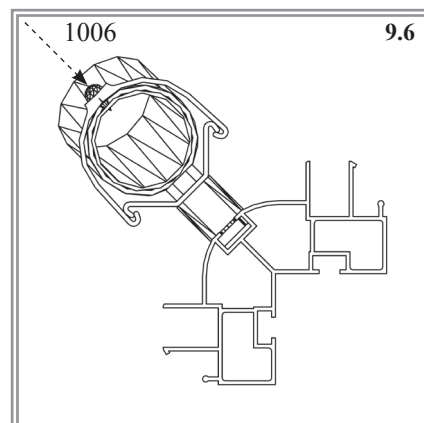
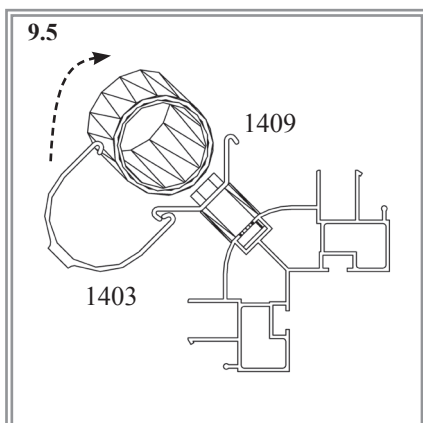
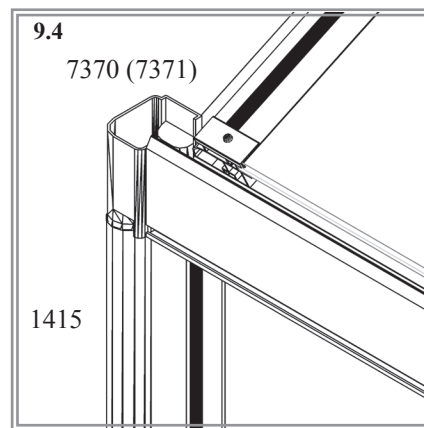
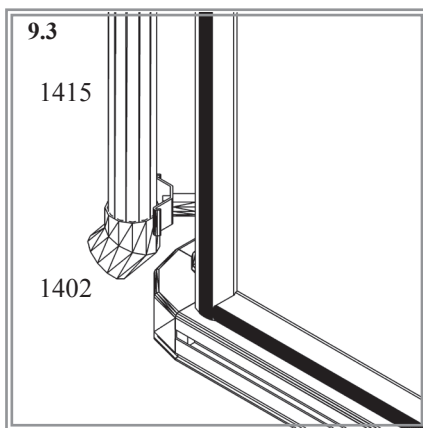



E.P.H. Schmidt u. Co. GmbH
Hoefkerstrasse 30
44149 Dortmund
Postfach 170163
44060 Dortmund
Deutschland
Tel.: +49 231 941655 0
Fax: +49 231 941655 99
www.eph-schmidt.de
verkauf@eph-schmidt.de

OPJ A/S
Volderslevvej 36 A
Postboks 480
5260 Odense S
Danmark
Tel.: +45 66 15 10 30
Fax: +45 66 15 00 84
www.opj.dk
opj@opj.dk

DE **Montageanleitung**

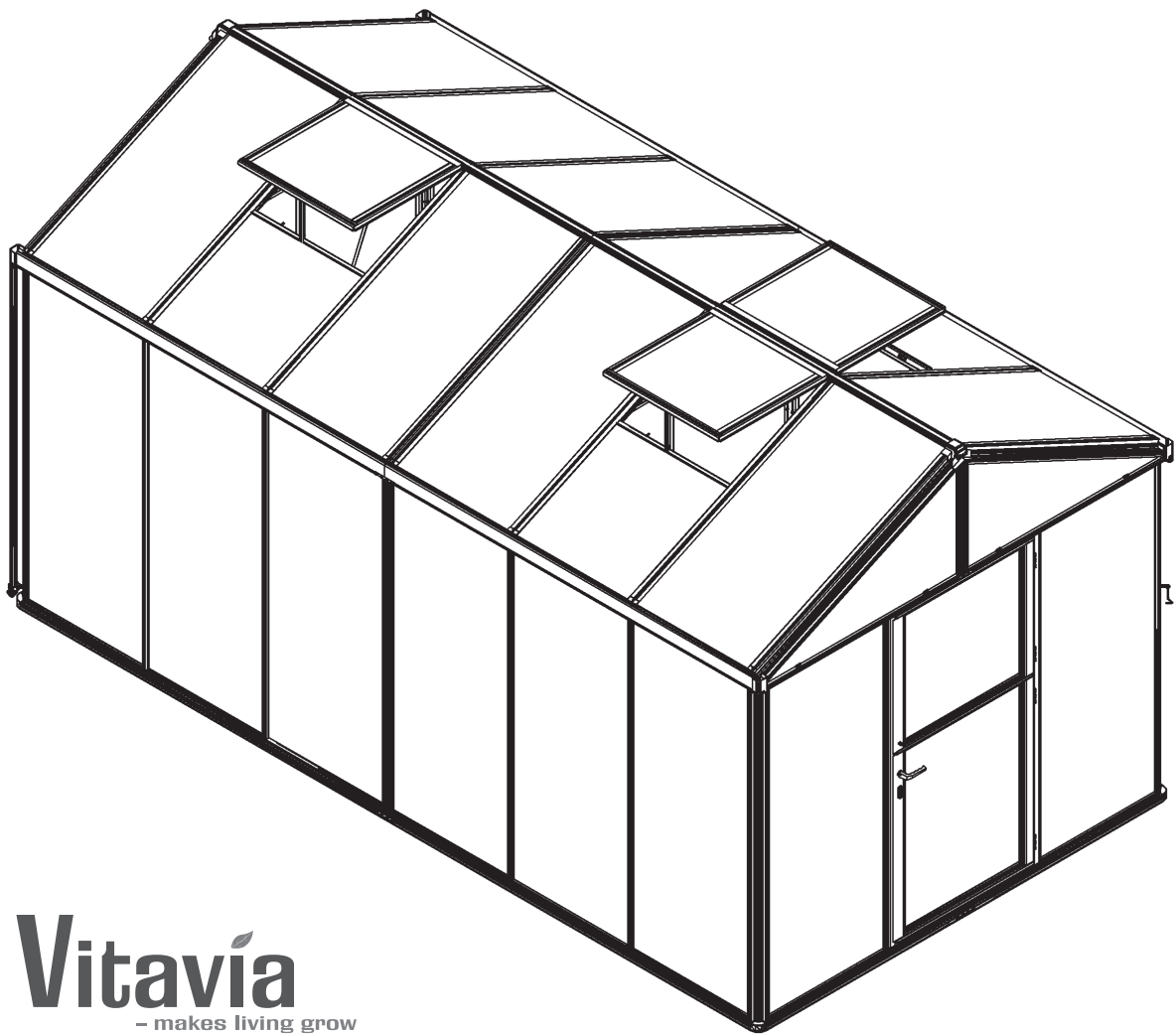

Vitavia
- makes living grow

ZEUS 2
8100, 10000, 11900, 13800, 15700

Sehr geehrte Kundin, sehr geehrter Kunde,

danke, dass Sie sich für unser Produkt entschieden haben.
Wir sind überzeugt, es wird Ihnen viel Freude bereiten.



Bitte lesen Sie diese Aufbauanleitung vor Beginn der Montage komplett durch!

• Inhalt / Symbole	S.70
• Empfehlungen	S.71
• Sicherheitshinweise	S.72
• Wartung und Pflege	S.73
• Stückliste / Tabelle	S.74
• Stückliste Pack 1-1	S. 75-77
• Stückliste Pack 1-2	S. 78-86
• Stückliste Pack 2	S. 87-91
• Stückliste Pack 3	S. 92-96
• Stückliste Pack 4	S. 97-101
• Stückliste Pack 5 - Fenster	S. 102-103
• Fundament	S. 104-105
Montage	
• Schritt 1 Grundrahmen u. Eckpfosten	S. 106-107
• Schritt 2 Zwischenprofil u. Traufenwinkel	S. 108-109
• Schritt 3 Zwischenprofile	S. 110-111
• Schritt 4 Dach	S. 112-115
• Schritt 5 Fenster	S. 116-117
• Schritt 6 Tür	S. 118-121
• Schritt 7 Verglasung	S. 122-131
• Schritt 8 Abschlussarbeiten	S. 132-133
• Schritt 9 Regenfallrohre	S. 134-135



**Abbildungen mit
einfachen Rahmen:
Innenansicht**



**wichtiger Hinweis,
unbedingt zu beachten**

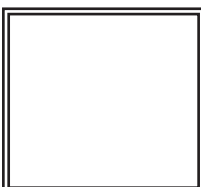

**Abbildungen mit
doppelten Rahmen:
Aussenansicht**



Bei der Handhabung von Glas, Hohlkammerplatten oder Gewächshausteilen sind immer eine Schutzbrille, Handschuhe, Sicherheitsschuhe und ein Kopfschutz zu tragen, da scharfe Kanten zu Verletzungen führen können. Gebrochenes Glas ist ein Sicherheitsrisiko. Beseitigen Sie es bitte mit der gebotenen Vorsicht.

Hinweis

Das von Ihnen erworbene Produkt ist für die Aufzucht von Pflanzen konstruiert und sollte auch ausschließlich dafür genutzt werden. Bei anderweitiger Nutzung ist jegliche Haftung ausgeschlossen.

Standortwahl

Suchen Sie den sonnigsten, aber gleichzeitig auch einen windgeschützten Platz für Ihr Gewächshaus aus. Die Standortwahl ist extrem wichtig für den Aufzucherfolg und die Sicherheit Ihres Hauses.

Bevor Sie beginnen

Bevor Sie mit der Montage Ihres Gewächshauses beginnen, überprüfen Sie, ob alle in der Liste aufgeführten Teile vorhanden sind. Nehmen Sie die einzelnen Bündel aus der Verpackung, um sie besser identifizieren zu können.

Die Teileliste ist kartonweise gegliedert.

Es ist wichtig, dass die geöffneten Bündel nicht durcheinander geraten.

Sollte trotz sorgfältigster Prüfung etwas fehlen, dann setzen Sie sich bitte mit Ihrem Lieferanten in Verbindung.

Sollte es einmal vorkommen, dass ein Teil vermeintlich nicht passt, fangen Sie nicht an zu bohren oder zu sägen. Kontaktieren Sie Ihren Vertragspartner. Der für Sie zuständige Kundendienst wird sich mit Ihnen in Verbindung setzen.

Weiterentwicklungen im Sinne des technischen Fortschritts behalten wir uns vor. So können geringfügige Abweichungen in den Darstellungen entstehen.

Folgende Werkzeuge werden für den Aufbau benötigt

- Kreuzschlitz-Schraubendreher (PH2)
- Schlitz Schraubendreher
- Gummihammer
- 1-2 Leitern (1.80m)
- Maulschlüssel Größe 10
- Wasserwaage
- Akkuschauber mit einstellbarem Drehmoment
- Spitzzange
- Bohrer Ø 20
- Teppichmesser

- **Bei der Handhabung von Glas, Hohlkammerplatten oder Gewächshausteilen sind immer eine Schutzbrille, Handschuhe, Sicherheitsschuhe und ein Kopfschutz zu tragen, da scharfe Kanten zu Verletzungen führen können. Gebrochenes Glas ist ein Sicherheitsrisiko. Beseitigen Sie es bitte mit der gebotenen Vorsicht.**
- **Es wird empfohlen, dieses Gewächshaus von 2-3 Personen aufbauen zu lassen.**
- **Achtung! Quetschgefahr bei der Montage.**
- **Beim Einbau der Verglasung zusätzlich eine Schutzbrille tragen.**
- **Montage darf nicht bei starkem Wind oder Sturm erfolgen.**
- **Nach 2 Wochen bitte alle Schraubverbindungen nachziehen**
- **Das Gewächshaus muss immer verankert werden.**
- **Kontrollieren Sie nach 14 Tagen den festen Sitz der Muttern.**
- **Dächer von Gewächshäusern sind so rechtzeitig von Schnee zu räumen, dass keine gefährliche Schneebelastung eintreten kann. Bei stärkeren Schneefällen muss das Dach schnellstmöglich freigeräumt werden.**
- **Bei starkem Wind sollten alle Öffnungen (Fenster und Türen) geschlossen werden, da der Wind sonst mehr Angriffsfläche erhält.**
- **Beheizen Sie das Gewächshaus im Winter.**



Bitte lesen Sie diese Montageanleitung vor Beginn des Aufbaus komplett durch!

Das Gewächshaus sollte hin und wieder gründlich mit einem neutralen Reinigungsmittel abgewaschen werden. Das Glas kann mit einem Reinigungsmittel gesäubert werden, das weder Kunststoffteile noch den Aluminiumrahmen angreift.

Sollten Sie unsicher sein, ob das von Ihnen verwendete Mittel verträglich ist, testen Sie es bitte zuerst an einer kleinen, der Sonne abgewandten Stelle.

Hinweis:



Zum vollen Schutz des Gewächshauses und zur generellen Vorbeugung empfehlen wir, das Gewächshaus mit in Ihre Hausrat- oder Gebäudeversicherung einzubeziehen. Wenden Sie sich zu diesem Zwecke an Ihren Versicherer.

Informieren Sie sich über evtl. vorhandene örtliche Bauvorschriften.

Bitte kleben Sie den beiliegenden Typenaufkleber nach dem Aufbau auf das Türprofil. Diese Modellbezeichnung ist wichtig, falls Sie später einmal Ersatzteile brauchen sollten. Bewahren Sie die Montageanleitung gut auf!



Folgen Sie genau den Angaben und Hinweisen dieser Bedienungsanleitung und Sie werden bei der Montage keine Schwierigkeiten haben. Sollten Ihnen vermeintliche Fehler in der Bedienungsanleitung auffallen oder ist Ihnen ein Passus unklar, wenden Sie sich bitte an Ihren Händler oder schreiben Sie uns an folgende e-Mail-Adresse:

kundendienst@eph-schmidt.de

Wir sind für Ihre Anregungen und Unterstützung dankbar.

Stückliste



Bitte überprüfen Sie zuerst anhand der Tabelle, ob Sie die korrekte Anzahl sowie die richtigen Packstücke vorliegen haben. Anhand der Stücklisten können die einzelnen Bündel überprüft werden.

Es ist wichtig, dass die geöffneten Bündel nicht durcheinander geraten.

Falls etwas fehlen sollte, wenden Sie sich bitte an Ihren Händler.



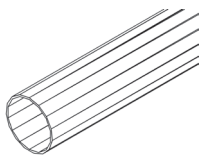
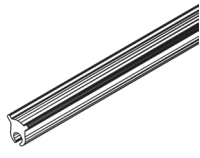

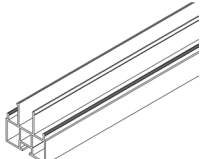
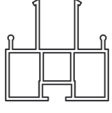
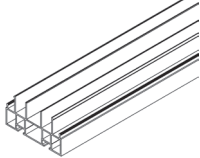
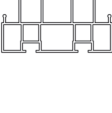
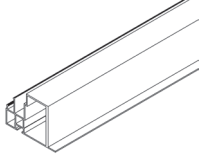
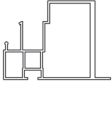
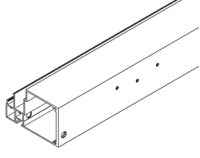
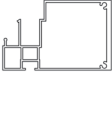
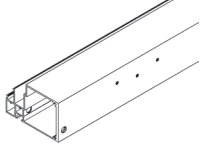
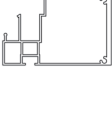
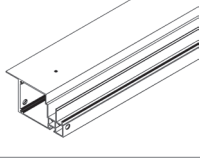
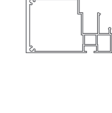
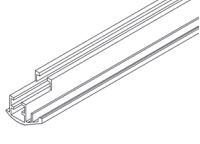
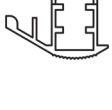

Model	Pack 1-1	Pack 1-2	Pack 2	Pack 3	Pack 4	Pack 5
8100	1	1	2			
10000	1	1	1	1		
11900	1	1		2		1
13800	1	1		1	1	1
15700	1	1			2	1

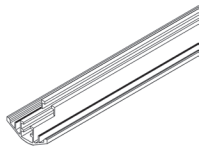

Stückliste

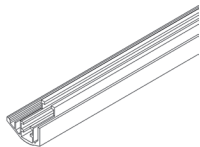
Pack 1-1					benötigte Stückzahl / Modell					
Teil Nr.	Teil	Aufbau- schritt	Größe mm	Anzahl im Karton	8100	10000	11900	13800	15700	Profil
1415		9	1750	2	2	2	2	2	2	
6090		7b 7c	56000	1	77000	85500	94000	103000	112000	
7005		3	1775	2	6	8	10	12	14	
7006		2	1775	3	3	3	3	3	3	
7014		2	1775	1	1	1	1	1	1	
7015		6b	1000	1	1	1	1	1	1	
7017		6a	717	1	1	1	1	1	1	
7018		6a	717	1	1	1	1	1	1	
7030		7b	1793	2	2	2	2	2	2	

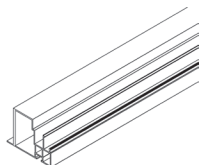
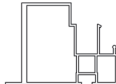
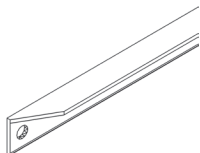
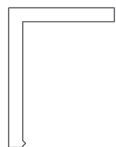
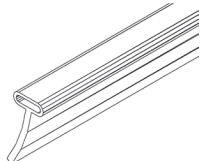
ZEUS 2

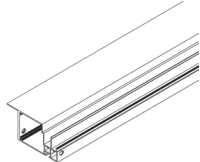
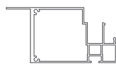
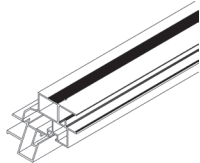
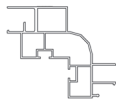
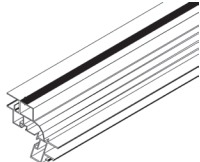
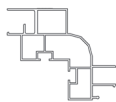
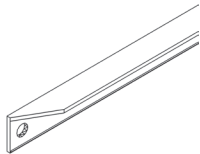
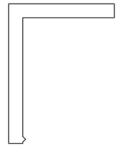
Stückliste

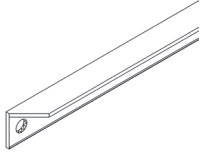





Pack 1-1					benötigte Stückzahl / Modell					
Teil Nr.	Teil	Aufbau- schritt	Größe mm	Anzahl im Karton	8100	10000	11900	13800	15700	Profil
7032		7b	1793	2	6	8	10	12	14	
7033		7b	1793	14	14	14	14	14	14	
7045		2	1775	1	1	1	1	1	1	
7069		3	1924	4	4	4	4	4	4	
7083		6a 6b	900	2	2	2	2	2	2	
7216		6b	1000	1	1	1	1	1	1	
7237		4a	1362	2	2	2	2	2	2	
7238		4a	1362	2	2	2	2	2	2	
7269		3	1926	4	4	4	4	4	4	

Pack 1-1					benötigte Stückzahl / Modell					
Teil Nr.	Teil	Aufbau-schritt	Größe mm	Anzahl im Karton	8100	10000	11900	13800	15700	Profil
7295		4a	1531.5	4	4	4	4	4	4	

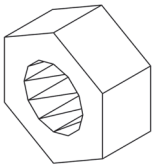
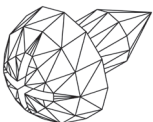
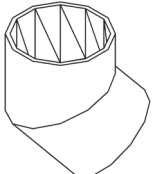
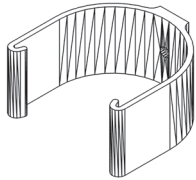

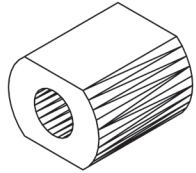

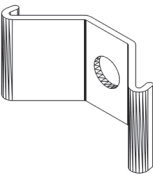

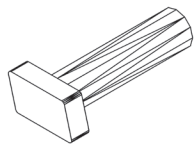
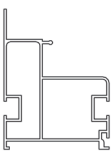
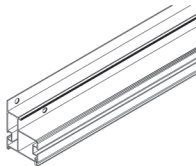
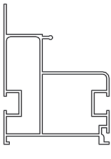
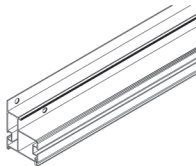
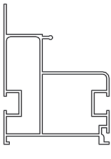

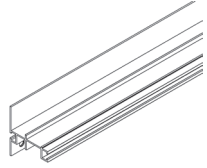
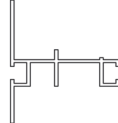
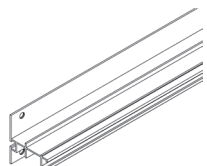
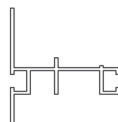
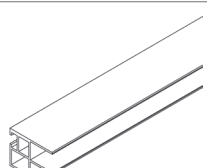
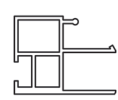
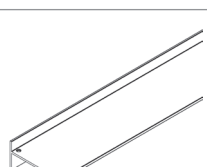

Stückliste

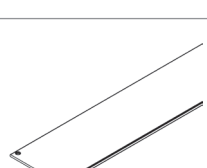
ZEUS 2

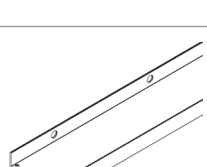
Stückliste

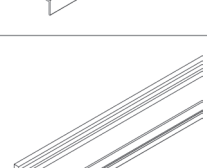

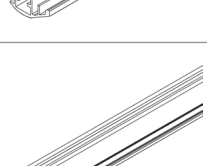
Pack 1-2					benötigte Stückzahl / Modell															
Teil Nr.	Teil	Aufbau- schritt	Größe mm	Anzahl im Karton	8100	10000	11900	13800	15700	Profil										
1002		9	M6	2	2	2	2	2	2											
1006		4b 5 6a 6b 9	3.5x6	22	32	32	38	38	38											
1402		9	36	2	2	2	2	2	2											
1403		9	20	2	2	2	2	2	2											
1405		9	15	2	2	2	2	2	2											
1409		9	20	2	2	2	2	2	2											
1412		9	M6x22	2	2	2	2	2	2											
7003	1	1230	2	2	2	2	2	2		7004		1	1230	2	2	2	2	2	2	
7004		1	1230	2	2	2	2	2	2											

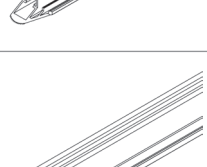
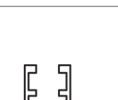
Stückliste

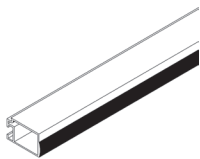
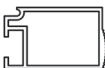
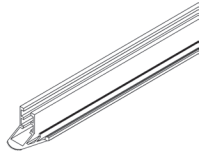
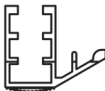
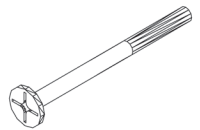
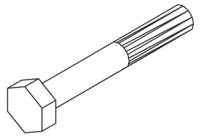
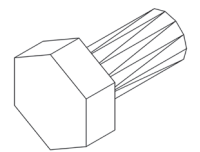
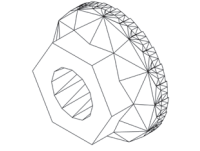

Pack 1-2					benötigte Stückzahl / Modell					
Teil Nr.	Teil	Aufbau- schritt	Größe mm	Anzahl im Karton	8100	10000	11900	13800	15700	Profil
7010		2	1229.5	2	2	2	2	2	2	
7011		2	1229.5	2	2	2	2	2	2	
7022		6a 6b	708	4	4	4	4	4	4	
7023		6b	850	1	1	1	1	1	1	
7024		6a	850	1	1	1	1	1	1	
7025		6a 6b	850	2	2	2	2	2	2	
7031		7c	996	2	2	2	2	2	2	
7034		7b 7c	733	8	16	18	20	22	24	
7035		7c	713	2	2	2	2	2	2	

ZEUS 2

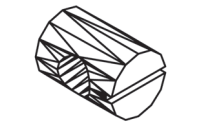
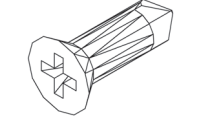
Stückliste

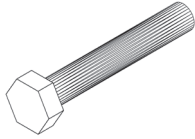
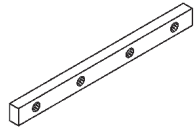
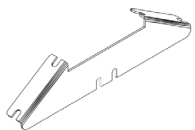

Pack 1-2					benötigte Stückzahl / Modell					
Teil Nr.	Teil	Aufbau- schritt	Größe mm	Anzahl im Karton	8100	10000	11900	13800	15700	Profil
7036		7b	922	1	1	1	1	1	1	
7044		7b	443	2	2	2	2	2	2	
7048		4b	M6x80	2	0	1	2	2	2	
7050		7b	M6x42	92	126	138	150	162	174	
7052		1, 2 3, 4 5, 6 7a	M6x12	104	154	176	202	224	246	
7053		1, 2 3, 4 5, 6 7, 8	M6x4	223	307	341	379	413	447	
7054		4b 6	M6x100	8	12	12	14	14	14	
7055		4b 6	M6x10 x14	8	12	12	14	14	14	
7056		8	3.9x13	4	4	4	4	4	4	

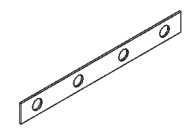
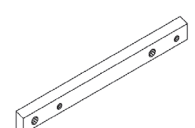
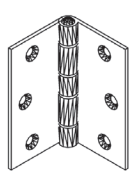
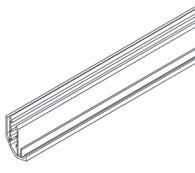
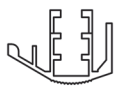
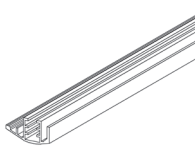
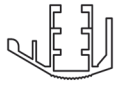
Stückliste

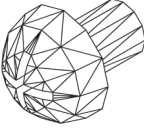
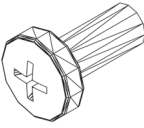
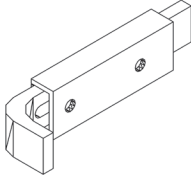
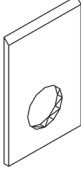
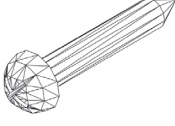
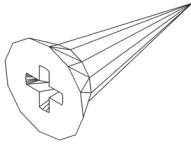
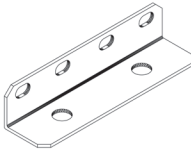

Pack 1-2					benötigte Stückzahl / Modell					
Teil Nr.	Teil	Aufbau- schritt	Größe mm	Anzahl im Karton	8100	10000	11900	13800	15700	Profil
7058		7c	M6x38	22	22	22	22	22	22	
7061		1 2 4a 7a	117	9	15	15	15	15	15	
7062		4	235	4	6	7	8	9	10	
7063		3	255	4	8	10	12	14	16	
7064		1 2 4a 7a	117	5	11	11	11	11	11	
7065		4a	140	2	2	2	2	2	2	
7066		6	75	4	4	4	4	4	4	
7074		7b	1369	2	2	2	2	2	2	
7075		7b	1369	2	2	2	2	2	2	

ZEUS 2

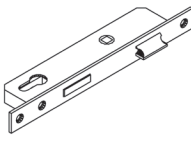
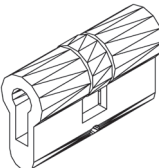
Stückliste



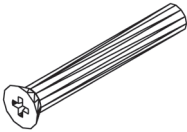
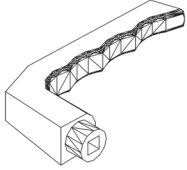
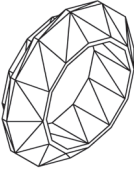
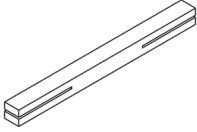
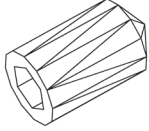
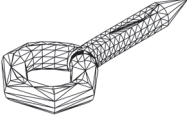
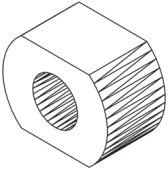

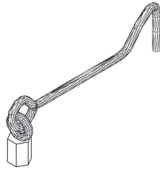

Pack 1-2					benötigte Stückzahl / Modell					
Teil Nr.	Teil	Aufbau- schritt	Größe mm	Anzahl im Karton	8100	10000	11900	13800	15700	Profil
7080		1 2 4a 7a	M6x8	36	60	60	60	60	60	
7081		4a	M5x13	4	4	4	4	4	4	
7085		6a	95	1	1	1	1	1	1	
7086		6b	23	1	1	1	1	1	1	
7087		6a	5x30	2	2	2	2	2	2	
7088		6 8	3.9x13	32	30	30	30	30	30	
7095		1	117	4	4	4	4	4	4	
7100		6b	244	1	1	1	1	1	1	
7101		6b	62	1	1	1	1	1	1	



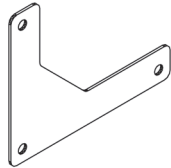
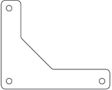
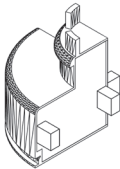
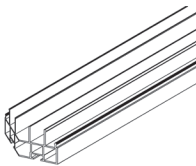
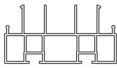
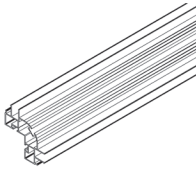
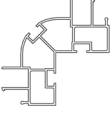
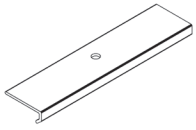

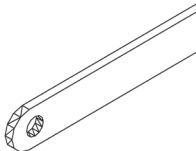
Stückliste

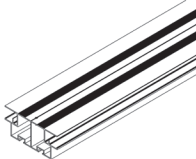
Pack 1-2					benötigte Stückzahl / Modell					
Teil Nr.	Teil	Aufbau- schritt	Größe mm	Anzahl im Karton	8100	10000	11900	13800	15700	Profil
7102		6b	M5x35	1	1	1	1	1	1	
7103		6b	65	2	2	2	2	2	2	
7104		6b	125	2	2	2	2	2	2	
7106		6b	Ø 27	2	2	2	2	2	2	
7107		6b	100	1	1	1	1	1	1	
7108		6b	4.7x8	2	2	2	2	2	2	
7111		8	35	1	1	1	1	1	1	
7112		8	8	1	1	1	1	1	1	
7113		8	100	1	1	1	1	1	1	

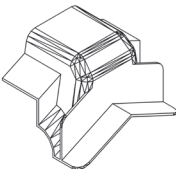
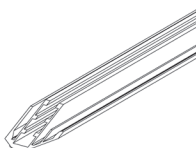
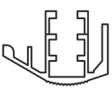
ZEUS 2

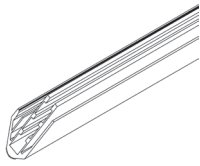
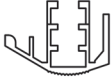
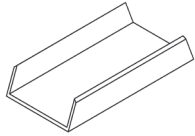
Stückliste

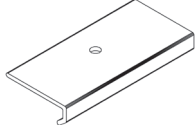

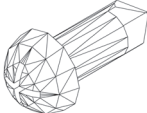
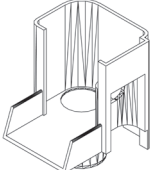
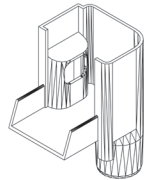
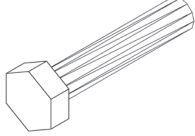
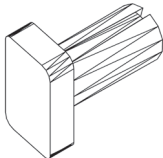
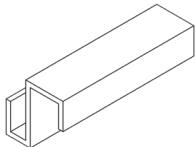
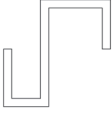



Pack 1-2					benötigte Stückzahl / Modell					
Teil Nr.	Teil	Aufbau- schritt	Größe mm	Anzahl im Karton	8100	10000	11900	13800	15700	Profil
7114		6	138	4	4	4	4	4	4	
7200		1	62	4	4	4	4	4	4	
7219		3	569.5	2	2	2	2	2	2	
7236		1	1775	4	4	4	4	4	4	
7240		7a	88	2	2	2	2	2	2	
7249		4b	1251	1	3	4	5	6	7	
7256		4a	1356	2	2	2	2	2	2	
7266		8	91	2	2	2	2	2	2	
7276		7b	582	2	2	2	2	2	2	

Pack 1-2					benötigte Stückzahl / Modell					
Teil Nr.	Teil	Aufbau- schritt	Größe mm	Anzahl im Karton	8100	10000	11900	13800	15700	Profil
7277		7b	582	2	2	2	2	2	2	
7292		7a	100	2	2	2	2	2	2	
7342		7a	45	4	4	4	4	4	4	
7349		7a 8	3.9x10	6	38	46	56	64	72	
7370		8	71	2	2	2	2	2	2	
7371		8	71	2	2	2	2	2	2	
7390		7b	M6x30	4	4	4	4	4	4	
7399		8	M6x12	1	1	1	1	1	1	
7406		7b	30	6	14	16	18	20	22	

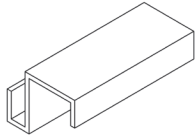

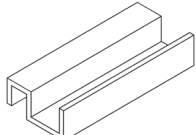
Stückliste

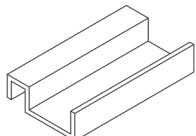
ZEUS 2

Stückliste

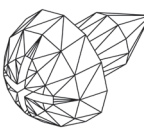
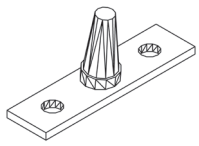
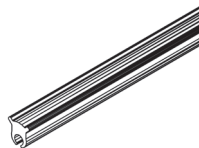

Pack 1-2					benötigte Stückzahl / Modell					
Teil Nr.	Teil	Aufbau- schritt	Größe mm	Anzahl im Karton	8100	10000	11900	13800	15700	Profil
7407		7b	30	6	14	16	18	20	22	
7408		7b	30	8	8	8	8	8	8	
7409		7b	30	8	8	8	8	8	8	

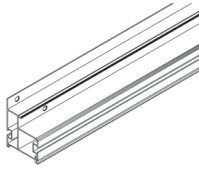
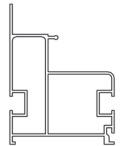
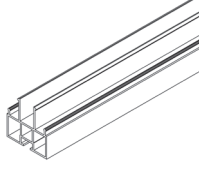
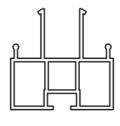
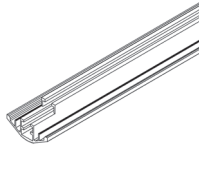
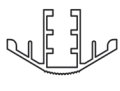
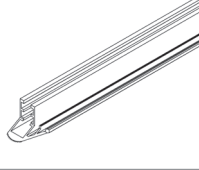
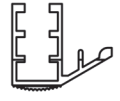
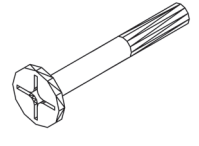
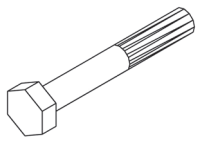
Stückliste





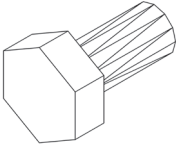
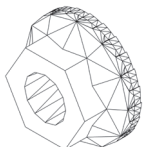

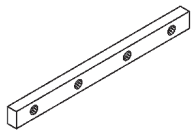
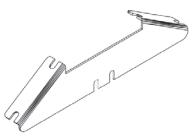
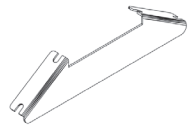
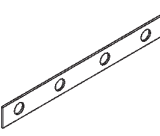
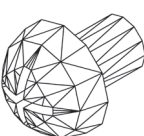
Pack 2					benötigte Stückzahl / Modell					
Teil Nr.	Teil	Aufbau- schritt	Größe mm	Anzahl im Karton	8100	10000	11900	13800	15700	Profil
1006		4b 5 6a 6b 9	3.5x6	6	32	32	38	38	38	
6056		4b	46	2	4	4	6	6	6	
6090		7b 7c	10500	1	77000	85500	94000	103000	112000	
7001		1	1520	2	4	2	-	-	-	
7005		3	1775	2	6	8	10	12	14	
7032		7b	1793	2	6	8	10	12	14	
7034		7b 7c	733	4	16	18	20	22	24	
7047		4b	M6x48	1	2	4	4	6	8	
7050		7b	M6x42	19	126	138	150	162	174	

ZEUS 2

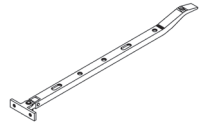
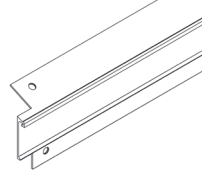
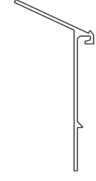
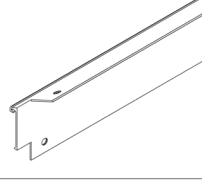
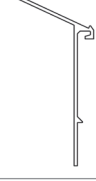
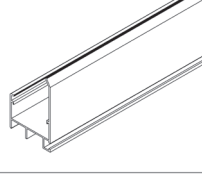
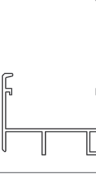
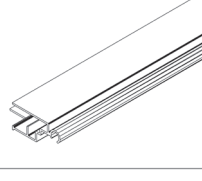
Stückliste

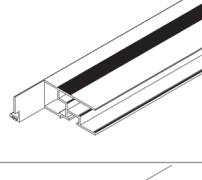

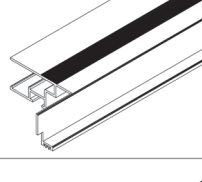

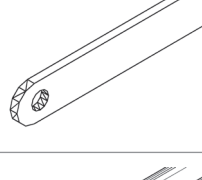
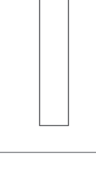
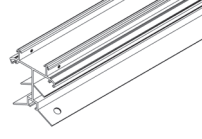
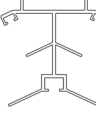





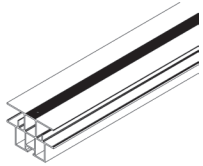

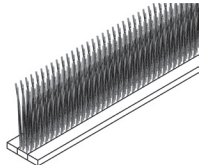

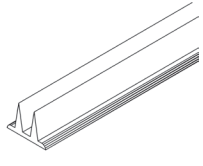
Pack 2					benötigte Stückzahl / Modell					
Teil Nr.	Teil	Aufbau- schritt	Größe mm	Anzahl im Karton	8100	10000	11900	13800	15700	Profil
7052		1, 2 3, 4 5, 6 7a	M6x12	30	154	176	202	224	246	
7053		1, 2 3, 4 5, 6 7, 8	M6x4	49	307	341	379	413	447	
7054		4b 6	M6x100	2	12	12	14	14	14	
7055		4b 6	M6x10 x14	2	12	12	14	14	14	
7061		1 2 4a 7a	117	3	15	15	15	15	15	
7062		4	235	1	6	7	8	9	10	
7063		3	255	2	8	10	12	14	16	
7064		1 2 4a 7a	117	3	11	11	11	11	11	
7080		1 2 4a 7a	M6x8	12	60	60	60	60	60	

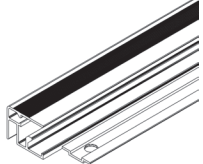

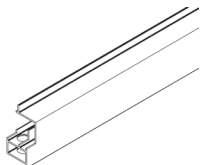
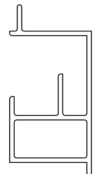
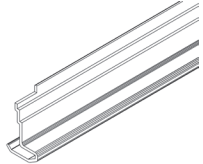

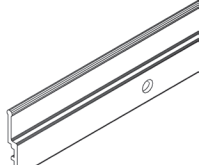
Stückliste

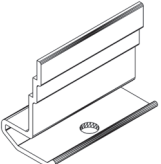
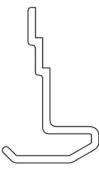
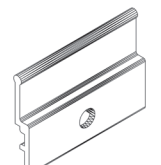
Pack 2					benötigte Stückzahl / Modell					
Teil Nr.	Teil	Aufbau- schritt	Größe mm	Anzahl im Karton	8100	10000	11900	13800	15700	Profil
7090		5	324	1	2	2	3	3	3	
7201		2	1539	1	2	1	-	-	-	
7202		2	1539	1	2	1	-	-	-	
7213		7a	1539	2	4	2	-	-	-	
7244		5	713	1	2	2	3	3	3	
7247 (7291)		5	674	1	2	2	3	3	3	
7248 (7291)		5	674	1	2	2	3	3	3	
7249		4b	1251	1	3	4	5	6	7	
7250		4a	1520	1	2	1	-	-	-	

ZEUS 2

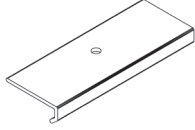

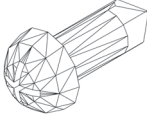
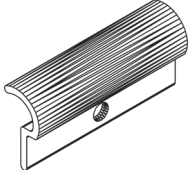

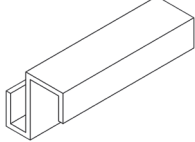
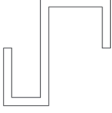
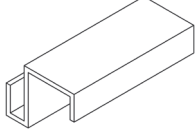
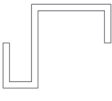
Stückliste

Pack 2					benötigte Stückzahl / Modell					Profil
Teil Nr.	Teil	Aufbau-schritt	Größe mm	Anzahl im Karton	8100	10000	11900	13800	15700	
7255		4b	1356	2	4	6	8	10	12	
7257		4a	1520	2	4	2	-	-	-	
7291 (7247 & 7248)		5	674	2	4	4	6	6	6	
7293		5	713	1	2	2	3	3	3	
7294		4b	708	1	2	2	3	3	3	
7296		7a	707	4	8	10	12	14	16	
7297		7a	687	4	8	10	12	14	16	
7298		7a*	30	4	8*	10*	12*	14*	16*	
7299		7a*	30	4	8*	10*	12*	14*	16*	

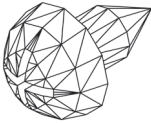
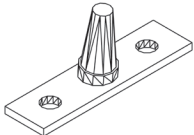
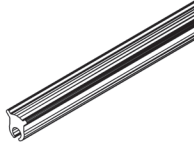

Pack 2					benötigte Stückzahl / Modell					
Teil Nr.	Teil	Aufbau- schritt	Größe mm	Anzahl im Karton	8100	10000	11900	13800	15700	Profil
7343		7a	56	2	4	6	8	10	12	
7349		7a 8	3.9x10	16	38	46	56	64	72	
7369		8	30	2	4	4	6	6	6	
7406		7b	30	4	14	16	18	20	22	
7407		7b	30	4	14	16	18	20	22	

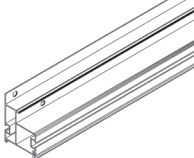
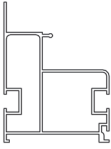
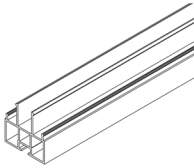
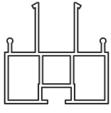
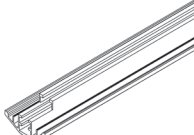
Stückliste

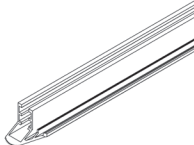
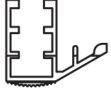
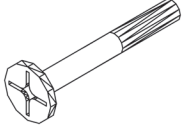
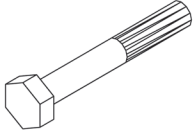
Stückliste



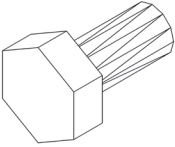

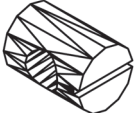
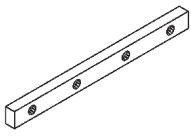
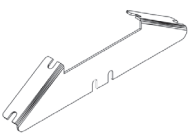
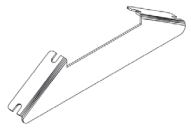
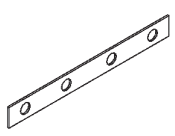
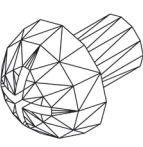

Pack 3					benötigte Stückzahl / Modell					
Teil Nr.	Teil	Aufbau- schritt	Größe mm	Anzahl im Karton	8100	10000	11900	13800	15700	Profil
1006		4b 5 6a 6b 9	3.5x6	6	32	32	38	38	38	
6056		4b	46	2	4	4	6	6	6	
6090		7b 7c	19000	1	77000	85500	94000	103000	112000	
7002		1	2264	2	-	2	4	2	-	
7005		3	1775	4	6	8	10	12	14	
7032		7b	1793	4	6	8	10	12	14	
7034		7b 7c	733	6	16	18	20	22	24	
7047		4b	M6x48	3	2	4	4	6	8	
7050		7b	M6x42	31	126	138	150	162	174	

Stückliste

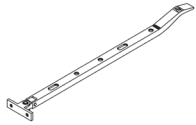
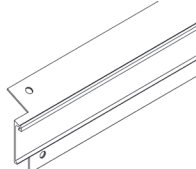

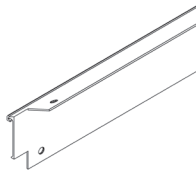
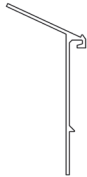
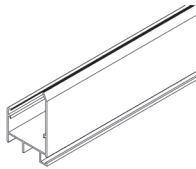
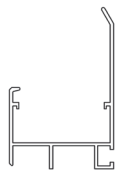
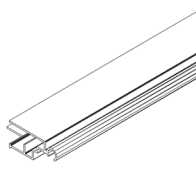

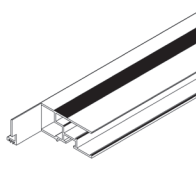
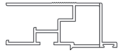
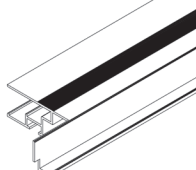
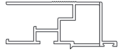
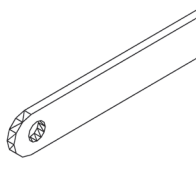

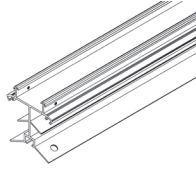
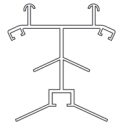
Pack 3					benötigte Stückzahl / Modell					
Teil Nr.	Teil	Aufbau-schritt	Größe mm	Anzahl im Karton	8100	10000	11900	13800	15700	Profil
7052		1, 2 3, 4 5, 6 7a	M6x12	52	154	176	202	224	246	
7053		1, 2 3, 4 5, 6 7, 8	M6x4	83	307	341	379	413	447	
7054		4b 6	M6x100	2	12	12	14	14	14	
7055		4b 6	M6x10 x14	2	12	12	14	14	14	
7061		1 2 4a 7a	117	3	15	15	15	15	15	
7062		4	235	2	6	7	8	9	10	
7063		3	255	4	8	10	12	14	16	
7064		1 2 4a 7a	117	3	11	11	11	11	11	
7080		1 2 4a 7a	M6x8	12	60	60	60	60	60	

ZEUS 2

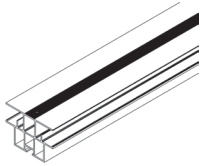
Stückliste

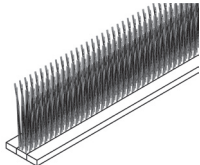

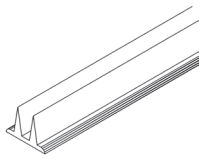

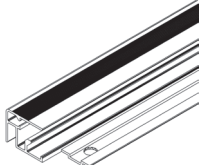
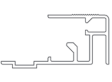
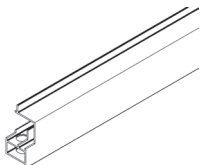
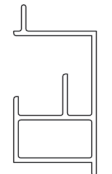
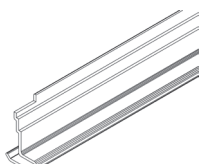
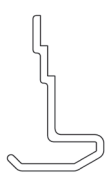
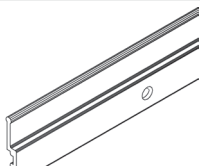
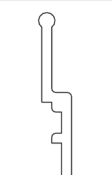
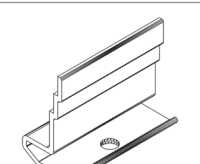
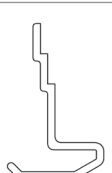
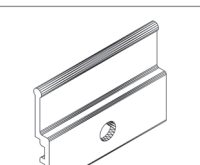
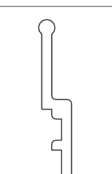

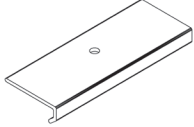

Pack 3					benötigte Stückzahl / Modell					
Teil Nr.	Teil	Aufbau- schritt	Größe mm	Anzahl im Karton	8100	10000	11900	13800	15700	Profil
7090		5	324	1	2	2	3	3	3	
7203		2	2283	1	-	1	2	1	-	
7204		2	2283	1	-	1	2	1	-	
7214		7a	2283	2	-	2	4	2	-	
7244		5	713	1	2	2	3	3	3	
7247 (7291)		5	674	1	2	2	3	3	3	
7248 (7291)		5	674	1	2	2	3	3	3	
7249		4b	1251	2	3	4	5	6	7	
7251		4a	2264	1	-	1	2	1	-	

Stückliste

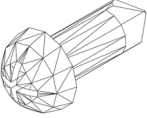
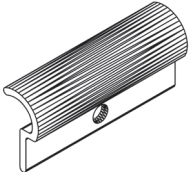

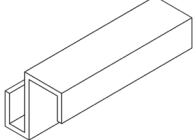

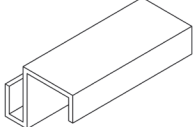

Pack 3					benötigte Stückzahl / Modell					
Teil Nr.	Teil	Aufbau- schritt	Größe mm	Anzahl im Karton	8100	10000	11900	13800	15700	Profil
7255		4b	1356	4	4	6	8	10	12	
7258		4a	2264	2	-	2	4	2	-	
7291 (7247 & 7248)		5	674	2	4	4	6	6	6	
7293		5	713	1	2	2	3	3	3	
7294		4b	708	1	2	2	3	3	3	
7296		7a	707	6	8	10	12	14	16	
7297		7a	687	6	8	10	12	14	16	
7298		7a*	30	6	8*	10*	12*	14*	16*	
7299		7a*	30	6	8*	10*	12*	14*	16*	

ZEUS 2

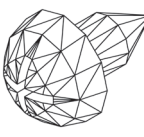
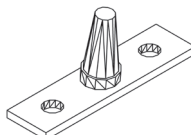
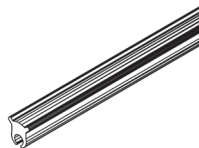
Stückliste

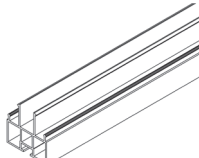
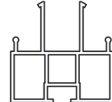
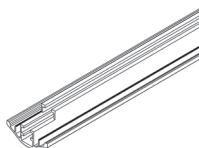

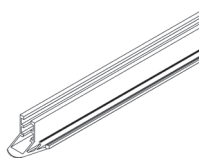

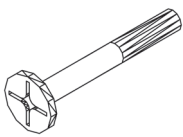
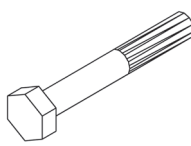
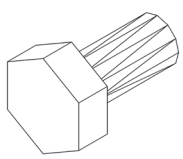
Pack 3					benötigte Stückzahl / Modell					
Teil Nr.	Teil	Aufbau- schritt	Größe mm	Anzahl im Karton	8100	10000	11900	13800	15700	Profil
7343		7a	56	4	4	6	8	10	12	
7349		7a 8	3.9x10	24	38	46	56	64	72	
7369		8	30	2	4	4	6	6	6	
7406		7b	30	6	14	16	18	20	22	
7407		7b	30	6	14	16	18	20	22	







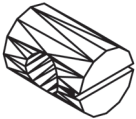
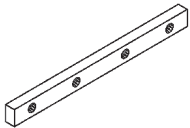
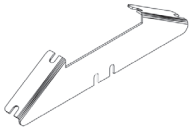

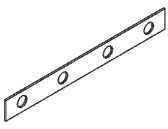
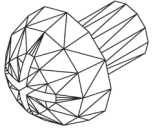
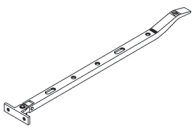
Stückliste

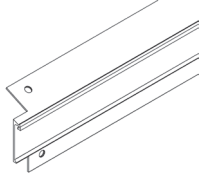
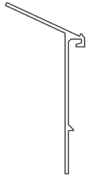
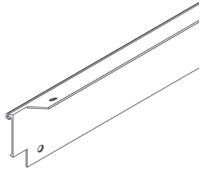
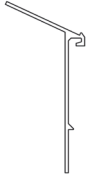
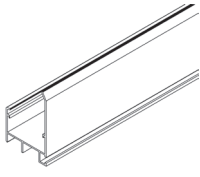
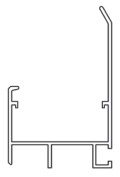
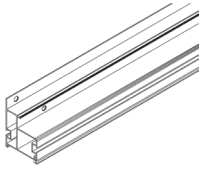
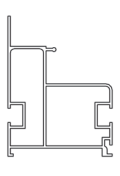
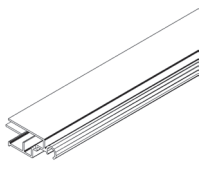
Pack 4					benötigte Stückzahl / Modell					
Teil Nr.	Teil	Aufbau- schritt	Größe mm	Anzahl im Karton	8100	10000	11900	13800	15700	Profil
1006		4b 5 6a 6b 9	3.5x6	6	32	32	38	38	38	
6056		4b	46	2	4	4	6	6	6	
6090		7b 7c	28000	1	77000	85500	94000	103000	112000	
7005		3	1775	6	6	8	10	12	14	
7032		7b	1793	6	6	8	10	12	14	
7034		7b 7c	733	8	16	18	20	22	24	
7047		4b	M6x48	5	2	4	4	6	8	
7050		7b	M6x42	43	126	138	150	162	174	
7052		1, 2 3, 4 5, 6 7a	M6x12	74	154	176	202	224	246	

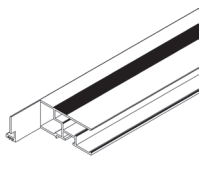
ZEUS 2

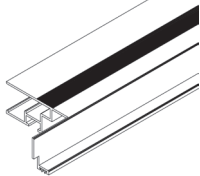
Stückliste

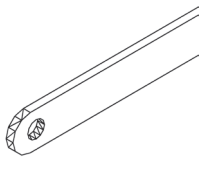

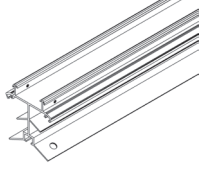
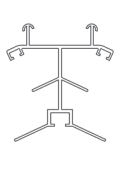



Pack 4					benötigte Stückzahl / Modell					
Teil Nr.	Teil	Aufbau- schritt	Größe mm	Anzahl im Karton	8100	10000	11900	13800	15700	Profil
7053		1, 2 3, 4 5, 6 7, 8	M6x4	117	307	341	379	413	447	
7054		4b 6	M6x100	2	12	12	14	14	14	
7055		4b 6	M6x10 x14	2	12	12	14	14	14	
7061		1 2 4a 7a	117	3	15	15	15	15	15	
7062		4	235	3	6	7	8	9	10	
7063		3	255	6	8	10	12	14	16	
7064		1 2 4a 7a	117	3	11	11	11	11	11	
7080		1 2 4a 7a	M6x8	12	60	60	60	60	60	
7090		5	324	1	2	2	3	3	3	



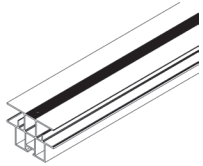

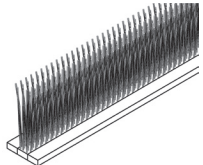

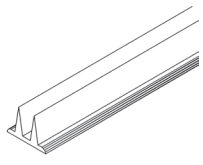

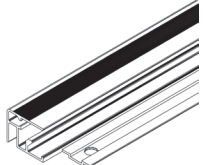
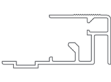
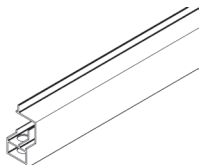
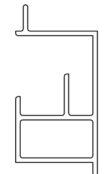
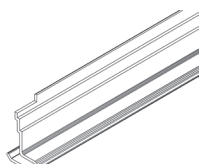
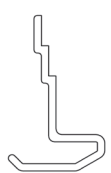
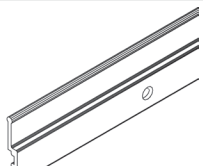
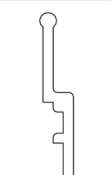
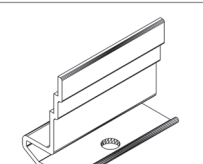
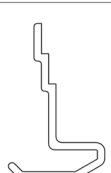
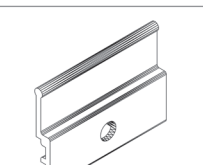
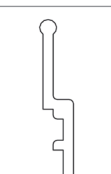
Pack 4					benötigte Stückzahl / Modell					
Teil Nr.	Teil	Aufbau- schritt	Größe mm	Anzahl im Karton	8100	10000	11900	13800	15700	Profil
7205		2	3027	1	-	-	-	1	2	
7206		2	3027	1	-	-	-	1	2	
7215		7a	3027	2	-	-	-	2	4	
7224		1	3008	2	-	-	-	2	4	
7244		5	713	1	2	2	3	3	3	
7247 (7291)		5	674	1	2	2	3	3	3	
7248 (7291)		5	674	1	2	2	3	3	3	
7249		4b	1251	3	3	4	5	6	7	
7252		4a	3008	1	-	-	-	1	2	

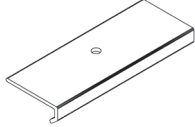
Stückliste

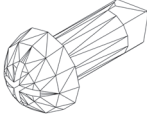
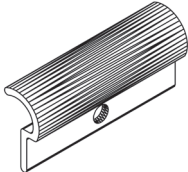
ZEUS 2

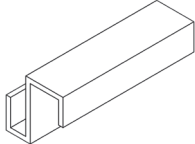

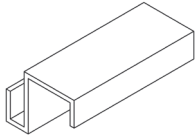

Stückliste

Pack 4					benötigte Stückzahl / Modell					
Teil Nr.	Teil	Aufbau- schritt	Größe mm	Anzahl im Karton	8100	10000	11900	13800	15700	Profil
7255		4b	1356	6	4	6	8	10	12	
7259		4a	3008	2	-	-	-	2	4	
7291 (7247 & 7248)		5	674	2	4	4	6	6	6	
7293		5	713	1	2	2	3	3	3	
7294		4b	708	1	2	2	3	3	3	
7296		7a	707	8	8	10	12	14	16	
7297		7a	687	8	8	10	12	14	16	
7298		7a*	30	8	8*	10*	12*	14*	16*	
7299		7a*	30	8	8*	10*	12*	14*	16*	



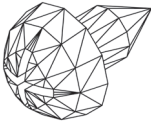
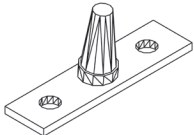
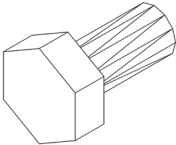

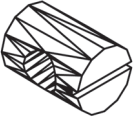
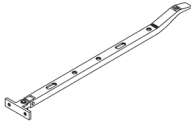
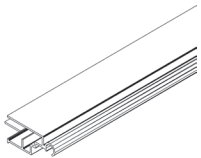
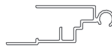
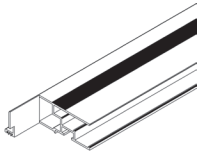
Pack 4					benötigte Stückzahl / Modell					
Teil Nr.	Teil	Aufbau- schritt	Größe mm	Anzahl im Karton	8100	10000	11900	13800	15700	Profil
7343		7a	56	6	4	6	8	10	12	
7349		7a 8	3.9x10	32	38	46	56	64	72	
7369		8	30	2	4	4	6	6	6	
7406		7b	30	8	14	16	18	20	22	
7407		7b	30	8	14	16	18	20	22	

Stückliste

Stückliste

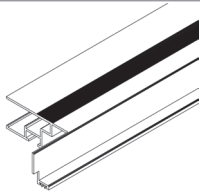
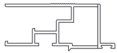
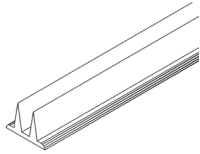
Pack 5 - Fenster					benötigte Stückzahl / Modell					
Teil Nr.	Teil	Aufbau- schritt	Größe mm	Anzahl im Karton	8100	10000	11900	13800	15700	Profil
1006		4b 5 6a 6b 9	3.5x6	6	32	32	38	38	38	
6056		4b	46	2	4	4	6	6	6	
7052		1, 2 3, 4 5, 6 7a	M6x12	4	154	176	202	224	246	
7053		1, 2 3, 4 5, 6 7, 8	M6x4	4	307	341	379	413	447	
7054		4b 6	M6x100	2	12	12	14	14	14	
7055		4b 6	M6x10 x14	2	12	12	14	14	14	
7090		5	324	1	2	2	3	3	3	
7244		5	713	1	2	2	3	3	3	
7247 (7291)		5	674	1	2	2	3	3	3	

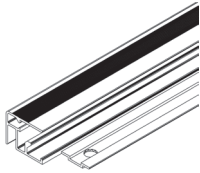
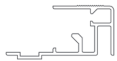
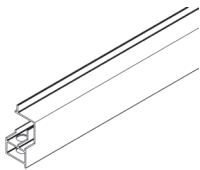
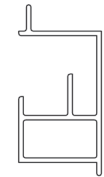
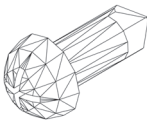
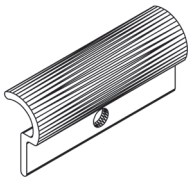
Stückliste

Pack 5 - Fenster					benötigte Stückzahl / Modell					
Teil Nr.	Teil	Aufbau- schritt	Größe mm	Anzahl im Karton	8100	10000	11900	13800	15700	Profil
7248 (7291)		5	674	1	2	2	3	3	3	
7291 (7247 & 7248)		5	674	2	4	4	6	6	6	
7293		5	713	1	2	2	3	3	3	
7294		4b	708	1	2	2	3	3	3	
7349		7a 8	3.9x10	2	38	46	56	64	72	
7369		8	30	2	4	4	6	6	6	



WICHTIG:

Alle Materialien, die zur Fundamentvorbereitung benötigt werden, sowie sämtliches Werkzeug sind nicht im Lieferumfang enthalten.



Angaben zum Fundament sind lediglich Empfehlungen

Für das Aufstellen des Gewächshauses benötigen Sie einen festen Sockel. Es ist möglich, diesen festen Sockel (das Fundament) aus Beton oder aus Mauerwerk zu fertigen. Sollten Sie über keinerlei Erfahrung mit Fundamentarbeiten verfügen, wenden Sie sich bitte an einen Fachmann.

Erstellen Sie nach den in der Tabelle angegebenen Maßen einen frostsicheren Sockel. Achten Sie genau auf die in der Tabelle angegebenen Rahmenmaße. Beachten Sie, dass zur Rahmenbefestigung mit den mitgelieferten Winkeln 7095 später auf der Innen- oder Außenseite 50 mm Platz benötigt werden. (Der Winkel 7095 benötigt 50 mm Platz).



WICHTIG:

Das Fundament muss genau in der Waage und absolut rechtwinklig sein! Hierzu benutzen Sie bitte eine Wasserwaage und ein Winkelmaß!

(Sind die gemessenen Diagonalen (X) gleich lang, so ist das Fundament rechtwinklig)

Bauen Sie Ihr Gewächshaus auf dem von Ihnen gefertigten Fundament auf.

Erst wenn alles im Winkel und fertig montiert ist, verbinden Sie den Sockel mit dem unteren Bodenrahmen des Hauses.

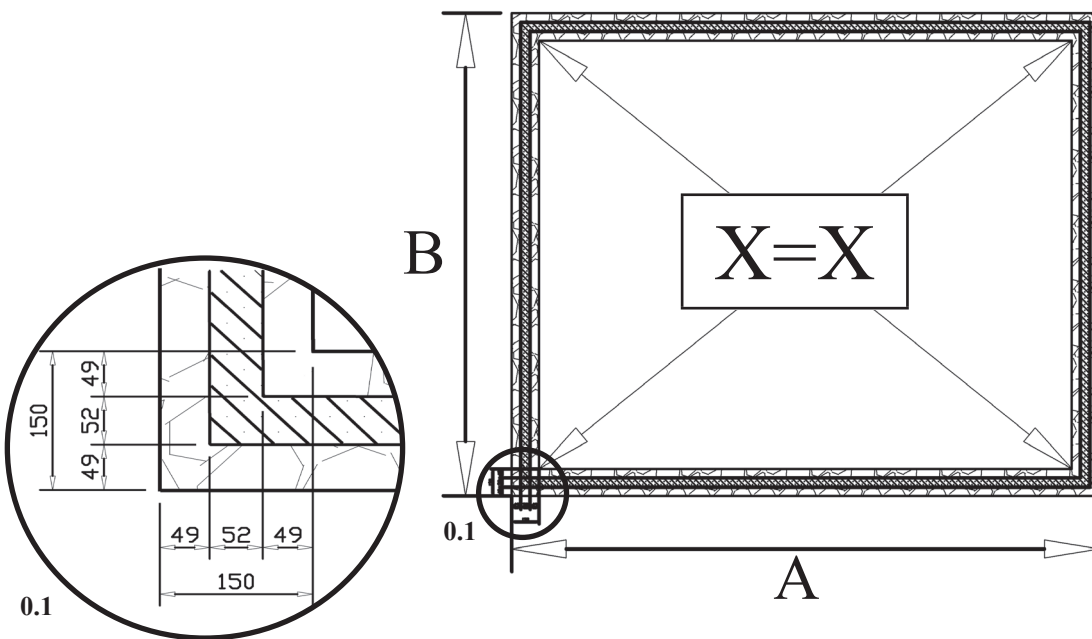
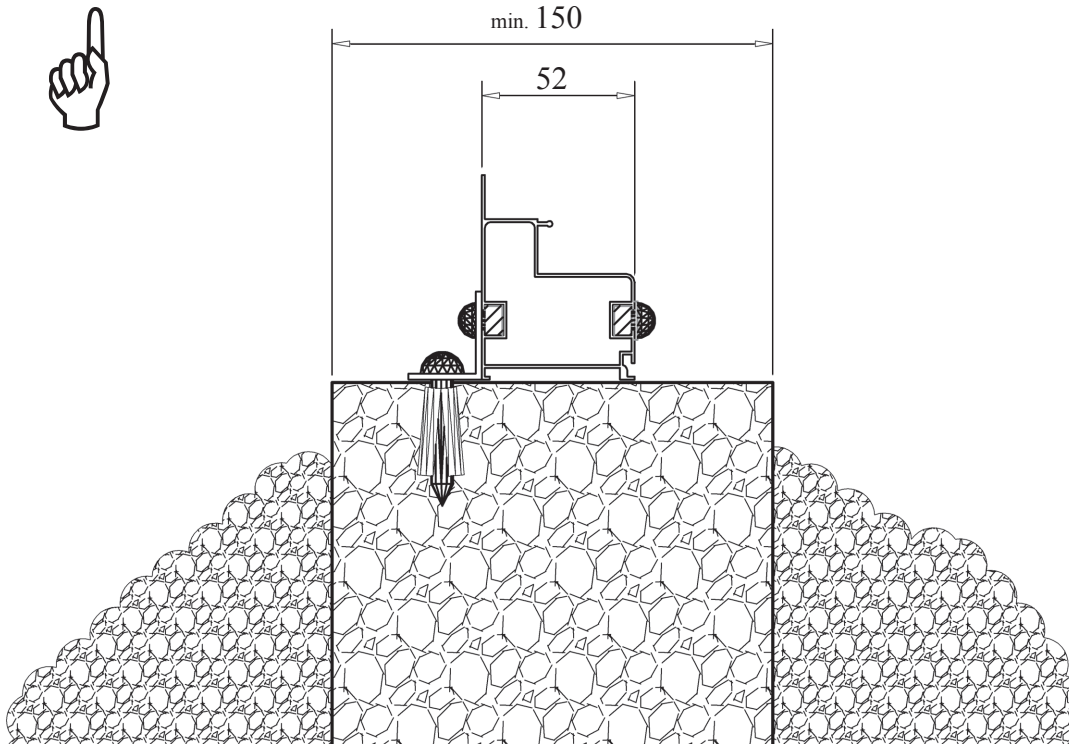

	8100	10000	11900	13800	15700
A	3242 mm	3986 mm	4730 mm	5474 mm	6218 mm
B	2662 mm	2662 mm	2662 mm	2662 mm	2662 mm

1

Modell				
8100	10000	11900	13800	15700
7001				
4	2	0	0	0
7002				
0	2	4	2	0
7003				
2	2	2	2	2
7004				
2	2	2	2	2
7052				
8	8	8	8	8
7053				
8	8	8	8	8
7061				
8	8	8	8	8
7064				
4	4	4	4	4
7080				
32	32	32	32	32
7095				
4	4	4	4	4
7200				
4	4	4	4	4
7224				
0	0	0	2	4
7236				
4	4	4	4	4

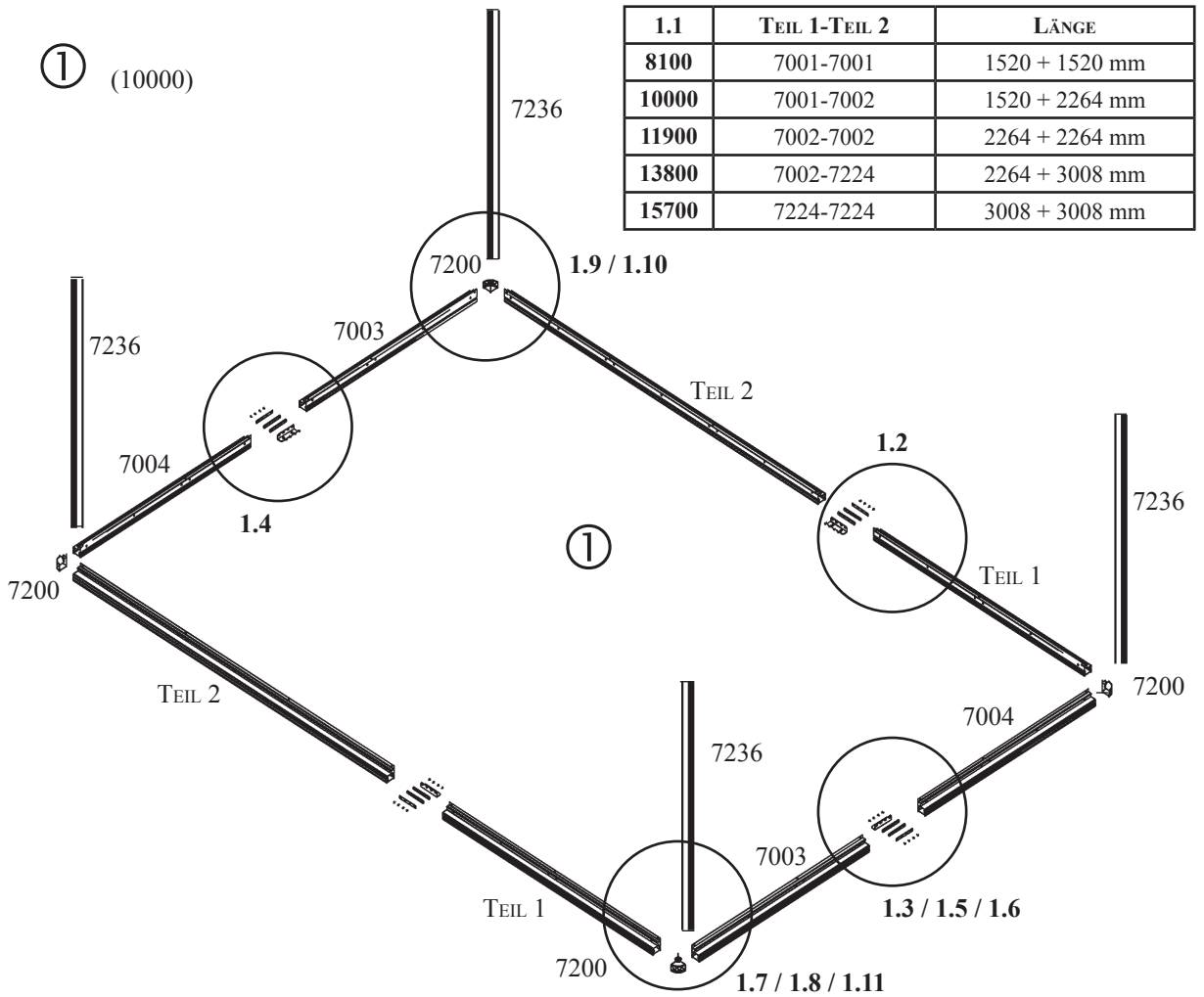

1.1	TEIL 1-TEIL 2	LÄNGE
8100	7001-7001	1520 + 1520 mm
10000	7001-7002	1520 + 2264 mm
11900	7002-7002	2264 + 2264 mm
13800	7002-7224	2264 + 3008 mm
15700	7224-7224	3008 + 3008 mm

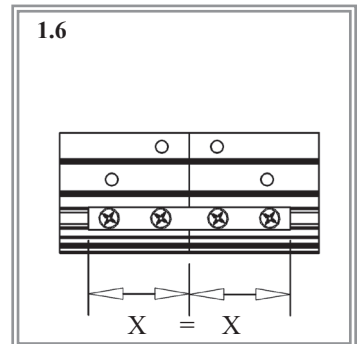
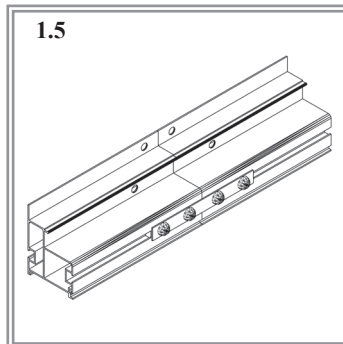
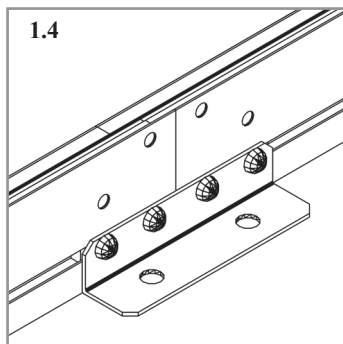
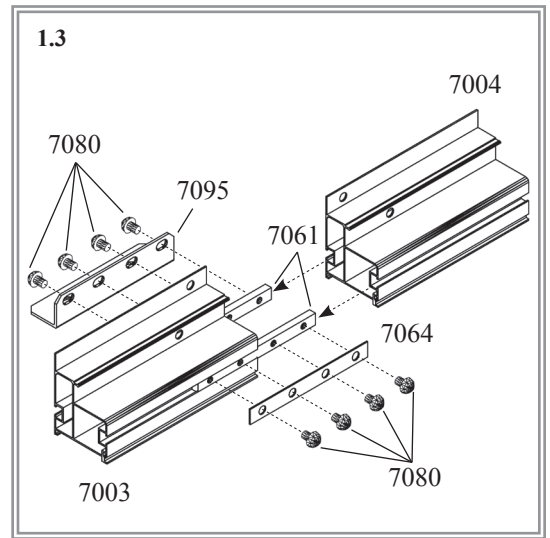
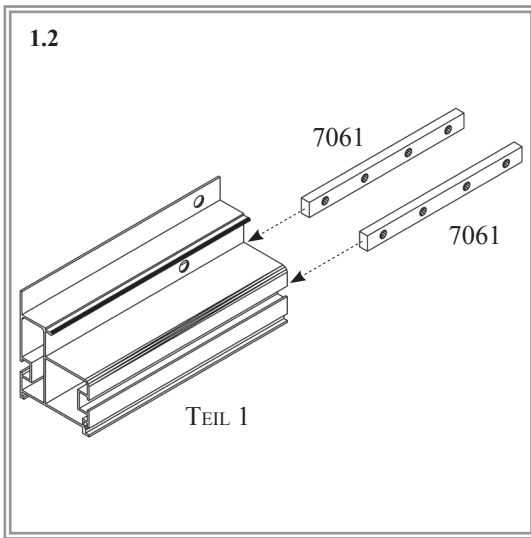

DER GRUNDRAHMEN / ECKPFOSTEN

BITTE BEACHTEN SIE...

Der Grundrahmen des Gewächshauses wird mit Hilfe der Winkel 7095 erst mit dem Fundament verschraubt, wenn das Gestell des Hauses komplett montiert wurde. Die Montage der senkrechten Profile sollte mit mindestens 2 Personen erfolgen.

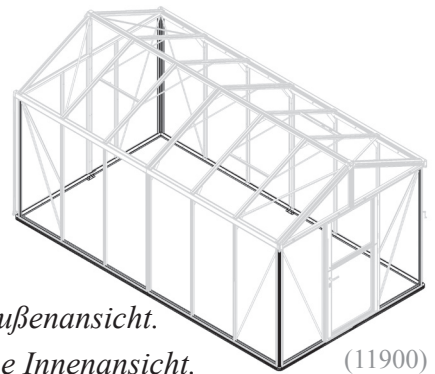

Abbildungen mit Doppelrahmen (z.B. 1.2) zeigen immer eine Außenansicht.

Abbildungen mit einfachen Rahmen (z.B. 1.4) zeigen immer eine Innenansicht.

Nehmen Sie die Alu-Kastenprofile 7003 bis 7004 aus Pack 1-2, Profile 7001, 7002 und 7224 aus Pack 2 bzw. Pack 3 oder Pack 4 und legen Sie diese wie in der Abb. 1 abgebildet auf dem Boden aus. Nehmen Sie die 4 Seitenprofile je nach Modell (Tabelle 1.1) und verbinden Sie diese mit Hilfe der Verbinder 7061 (1.2).

Verschrauben Sie die Profilverbinder 7061 und 7064 bzw. 7095 mit der Schraube 7080 (1.3). Die Verbinder müssen mittig plaziert werden. (1.6) Verfahren Sie mit den Profilen 7003 und 7004 in gleicher Weise.

Anschließend verbinden Sie die Bodenprofile mit den abgerundeten Eckverbindern 7200 (1.7/1.8) sowie den Eckpfosten 7236 (1.9/1.10).

Die Eckpfosten werden unten mit je 2 Schrauben 7052 und 2 Muttern 7053 befestigt (1.9 - 1.11). Verbinden Sie zunächst die Schrauben und Muttern lose und führen dann den Eckpfosten auf die Schraubköpfe. Dabei müssen die Schraubköpfe so ausgerichtet werden, dass sie in die Schraubenkanäle des Pfostens eingeführt werden können. Die Muttern 7053 fest anziehen (1.10). Überprüfen Sie, ob die Profile im rechten Winkel zueinander stehen.

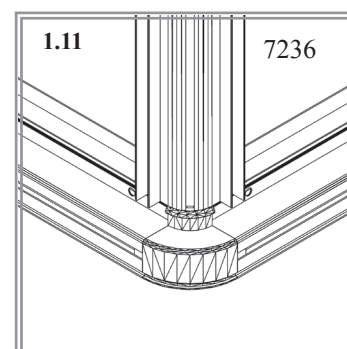
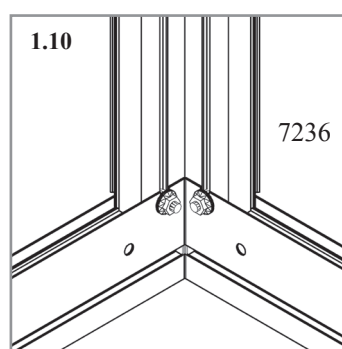
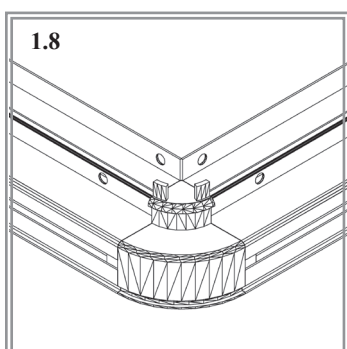
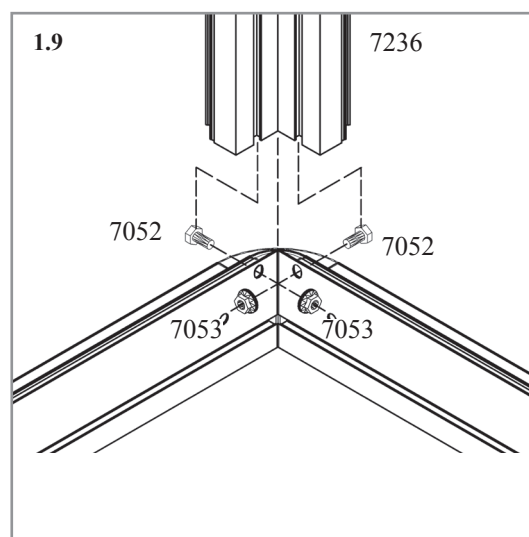
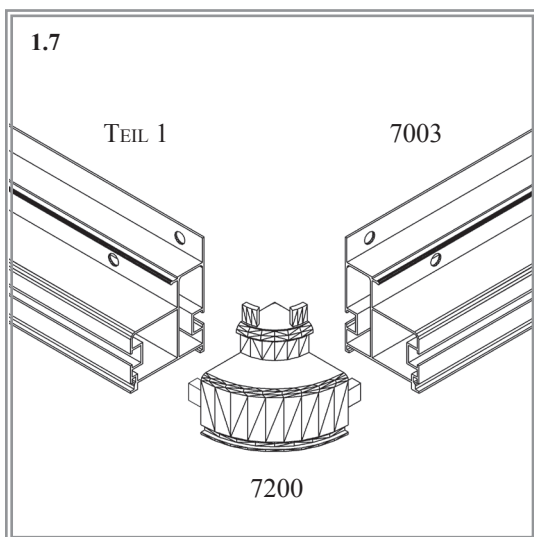

Modell				
8100	10000	11900	13800	15700
7006				
3	3	3	3	3
7010				
2	2	2	2	2
7011				
2	2	2	2	2
7014				
1	1	1	1	1
7045				
1	1	1	1	1
7052				
32	32	32	32	32
7053				
32	32	32	32	32
7061				
4	4	4	4	4
7064				
4	4	4	4	4
7080				
16	16	16	16	16
7201				
2	1	0	0	0
7202				
2	1	0	0	0
7203				
0	1	2	1	0
7204				
0	1	2	1	0
7205				
0	0	0	1	2
7206				
0	0	0	1	2

② (10000)

2.1	TEIL 1-TEIL 2-TEIL 3-TEIL 4	LÄNGE (TEIL 1/TEIL 2) - (TEIL 3/TEIL 4)
8100	7201-7202-7201-7202	1539 + 1539 mm
10000	7201-7202-7203-7204	1539 + 2283 mm
11900	7203-7204-7203-7204	2283 + 2283 mm
13800	7203-7204-7205-7206	2283 + 3027 mm
15700	7205-7206-7205-7206	3027 + 3027 mm

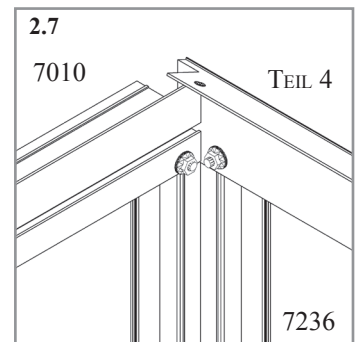
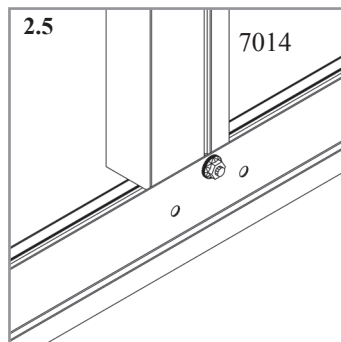
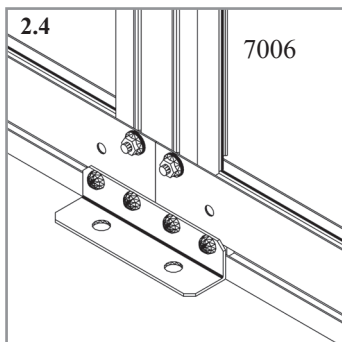
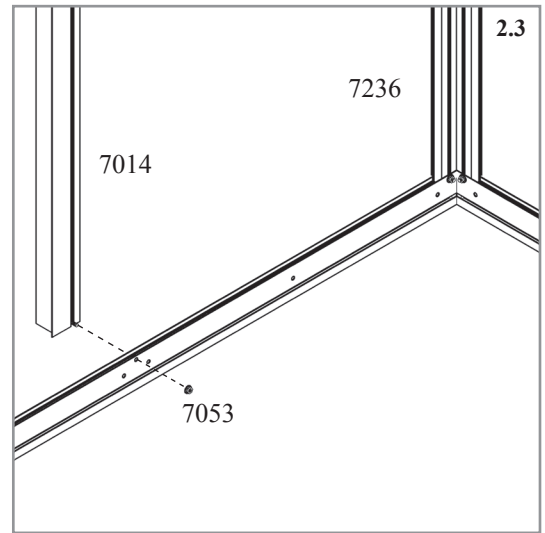
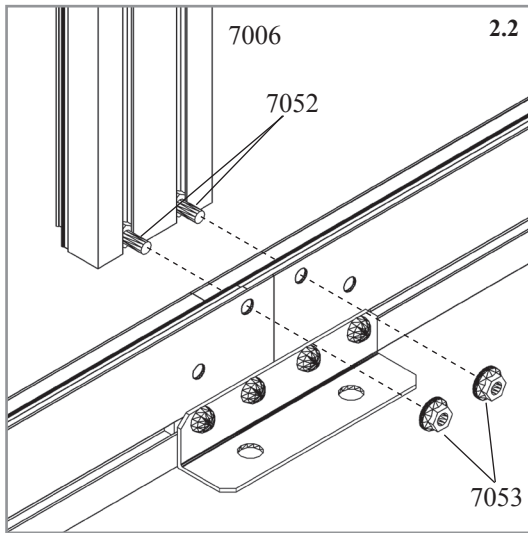
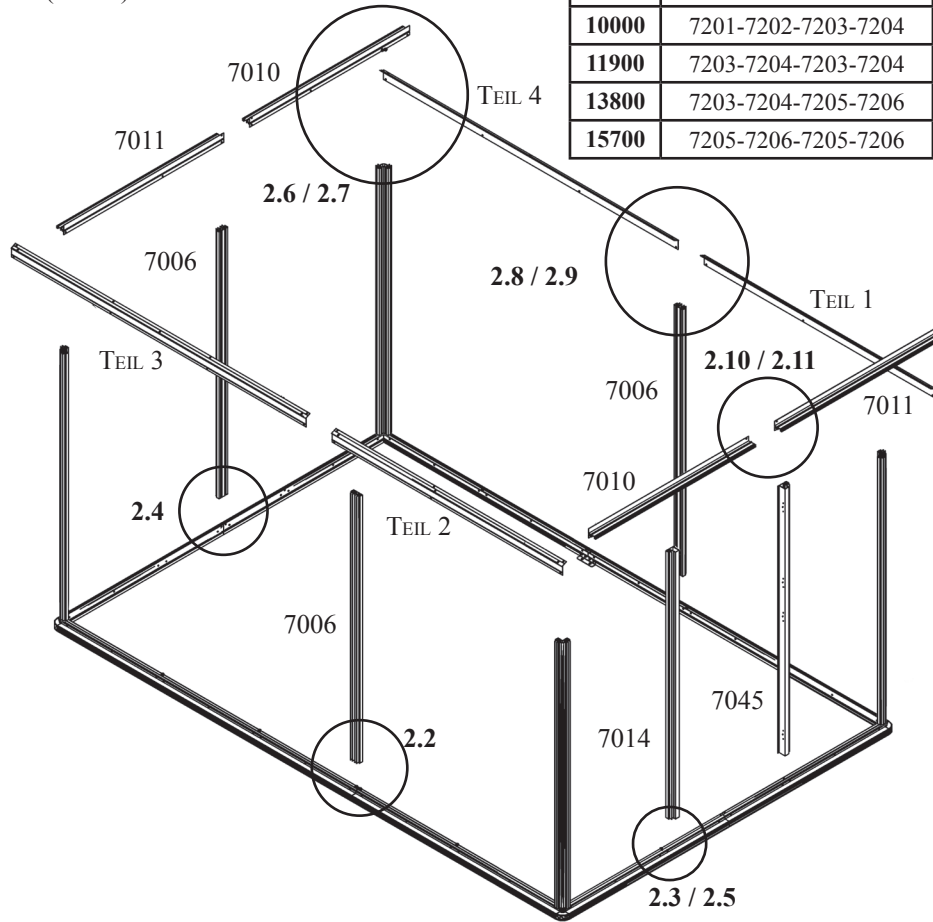

ZEUS 2

ZWISCHENPROFILE / TRAUFWINKEL

BITTE BEACHTEN SIE...

In diesem Aufbausritt sollten Sie mit 2 oder 3 Personen arbeiten. Alle Muttern nur leicht anziehen. Diese müssen wieder gelöst werden um weitere Profile zu montieren.

Die Detailzeichnungen sind von Innen gesehen.

"Leerschraube" = Schraube und Mutter für die spätere Befestigung von Teilen, vorerst ohne sichtbare Funktion.

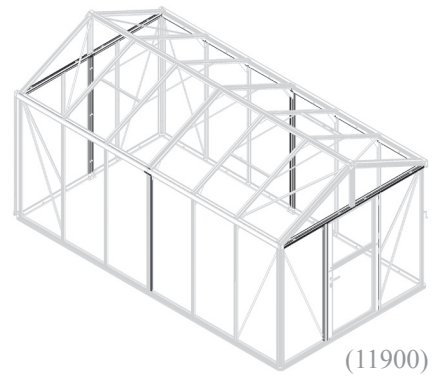



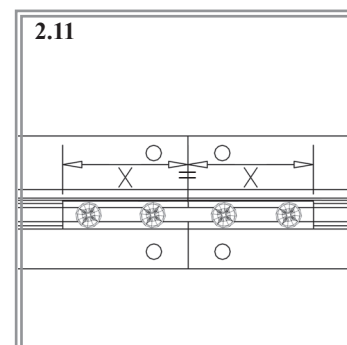
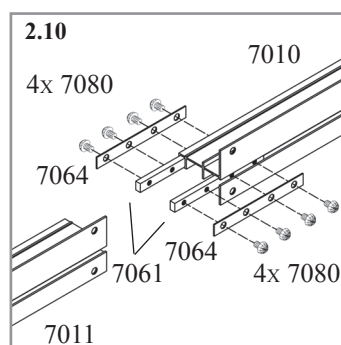
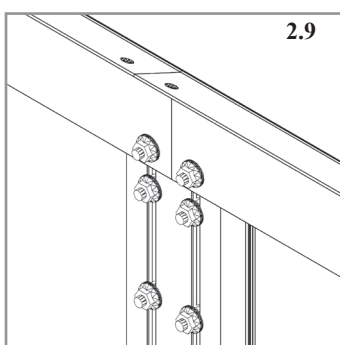
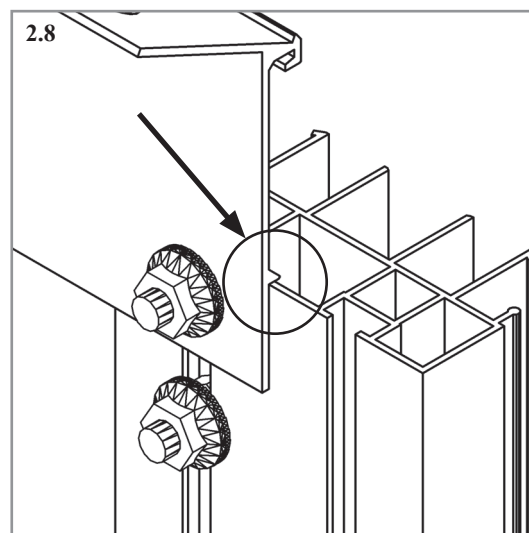
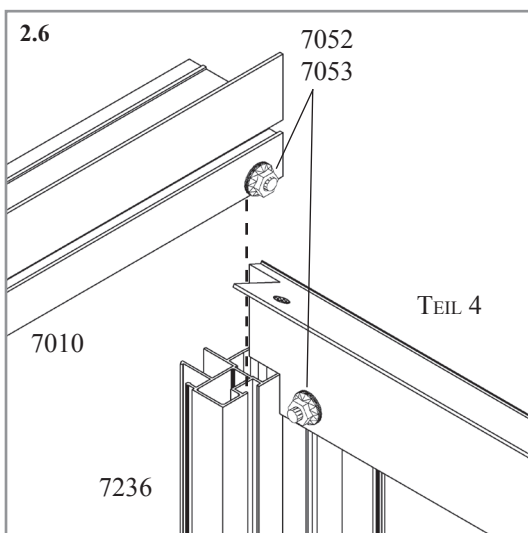



Nehmen Sie 2 Zwischenprofile 7006 und führen Sie in jeden Schraubenkanal 2 Leerschrauben 7052 ein und fixieren diese mit je einer Mutter 7053 (2.9.). Hiermit werden später die Knotenbleche 7063 der Seitenwände befestigt. Nehmen Sie die Profile 7006 und montieren Sie diese mit den Schrauben 7052 und Muttern 7053 am Bodenrahmen (2.2). Verbinden Sie die Zwischenprofile 7006 und die Eckpfosten 7236 mit den Traufwinkeln (Tabelle 2.1) (Abb. 2.6-2.9). Beachten Sie, dass die Traufwinkel in den Eckpfosten gedrückt 7236 (2.6) gedrückt werden und dass die Montagekante richtig sitzt (2.8). Jetzt können die Horizontalprofile 7010 und 7011 gem. Abb. 2.10 vormontiert werden. Bereiten Sie die Profile so vor, dass diese mit je 2 Profilverbindern 7061 sowie 7064 mit den Schrauben 7080 außen und innen verbunden werden. Kontrollieren Sie am Ende, ob die Verbinder mittig angeordnet sind. (2.11). und ziehen Sie alle Schrauben 7080 an. Anschließend montieren Sie die so vorbereiteten Profile 7010 / 7011 an der Front und Rückwand mit den Schrauben 7052 und Muttern 7053 an den Eckpfosten 7236 (2.6)(2.7). Montieren Sie die Zwischenprofile 7006 an der Rückwand und 7014 und 7045 an der Vorderseite, wobei Sie in die Schraubenkanäle Schrauben 7052 einführen und dann mit den Horizontalprofilen 7010/7011 mit den Schrauben 7053 montieren (2.2 – 2.5).



Zwischenprofile / Traufwinkel

ZEUS 2

Modell				
8100	10000	11900	13800	15700
7005				
6	8	10	12	14
7052				
28	36	44	52	60
7053				
28	36	44	52	60
7063				
8	10	12	14	16
7069				
4	4	4	4	4
7219				
2	2	2	2	2
7269				
4	4	4	4	4

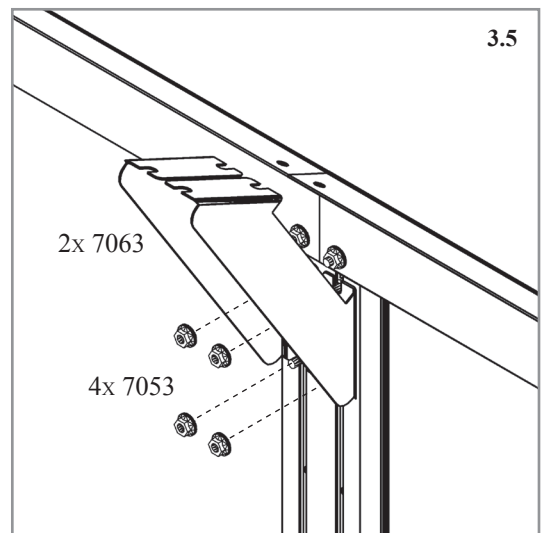
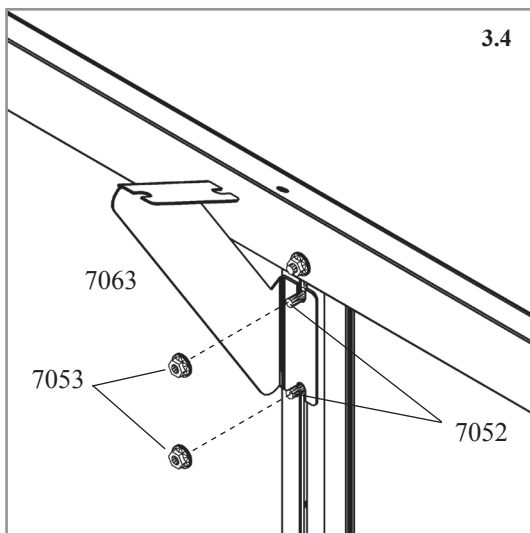
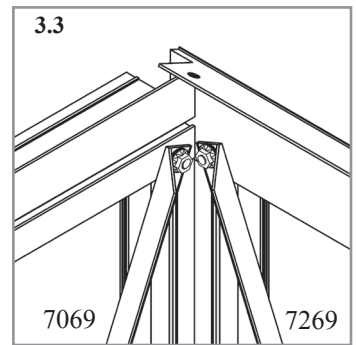
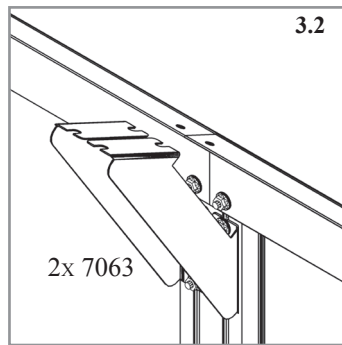
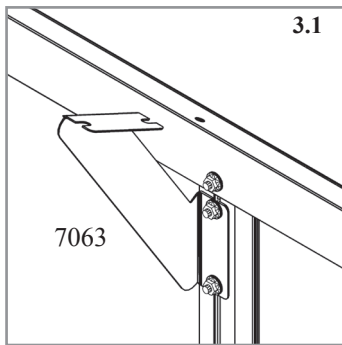
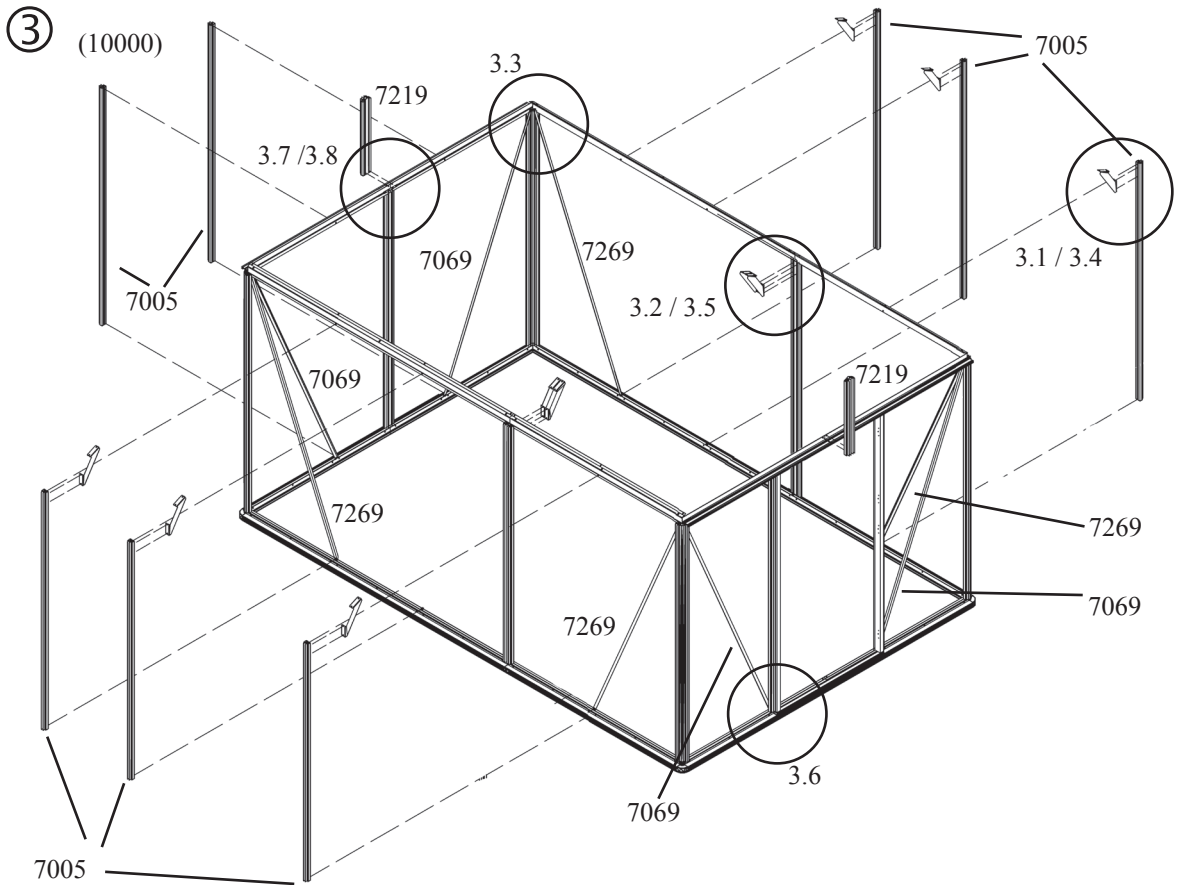

ZWISCHENPROFILE

BITTE BEACHTEN SIE...

In diesem Aufbauschnitt werden die Diagonalstreben 7069 und 7269 montiert. Zuvor erstellte Verbindungen müssen wieder gelöst werden. Hierbei kann es vorkommen, dass Streben zu kurz oder zu lang erscheinen. Durch leichtes Verschieben über die Diagonale des Hauses wird das Haus ausgerichtet bis die Diagonalstreben passen.

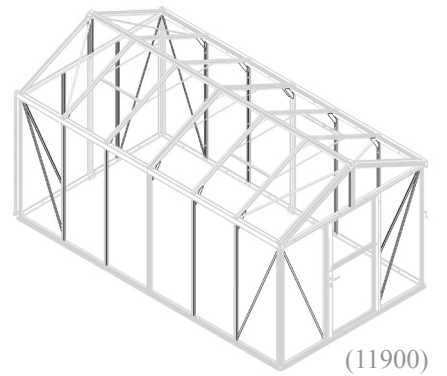

Nehmen Sie die folgende Anzahl an Zwischenprofilen 7005: Modell 8100 – 4, Modell 10000 – 6, Modell 11900 – 8, Modell 13800 - 10, Modell 15700 - 12 und führen Sie in den Schraubenkanal 2 Leerschrauben 7052 ein und fixieren diese lose mit je einer Mutter 7053. Hiermit werden später die Knotenbleche 7063 der Seitenwände befestigt. Montieren Sie die so vorbereiteten Profile 7005 an den Seitenwänden gem. Abb. 3. Führen Sie Leerschrauben in die Schraubenkanäle der Zwischenprofile 7005 und 7006 ein und befestigen Sie lose die Knotenbleche 7063 (3.1, 3.2, 3.4, 3.5). Die genaue Position (Höhe) der Knotenbleche wird erst später festgelegt, wenn das Dach montiert ist.

An der Rückwand montieren Sie die restlichen Zwischenprofile 7005 gemäß Abb. 3. Montieren Sie die Diagonalstreben 7069 und 7269 (3.3) (3.6). Hierbei kann es vorkommen, dass Streben zu kurz oder zu lang erscheinen. Durch leichtes Verschieben über die Diagonale des Hauses wird das Haus ausgerichtet bis die Diagonalstreben passen. Montieren Sie nun die Firststützen 7219 (3.7) (3.8) und führen je eine Leerschraube 7052 mit Mutter 7053 in jeden Schraubenkanal 7219 (3.7)(4a.3).

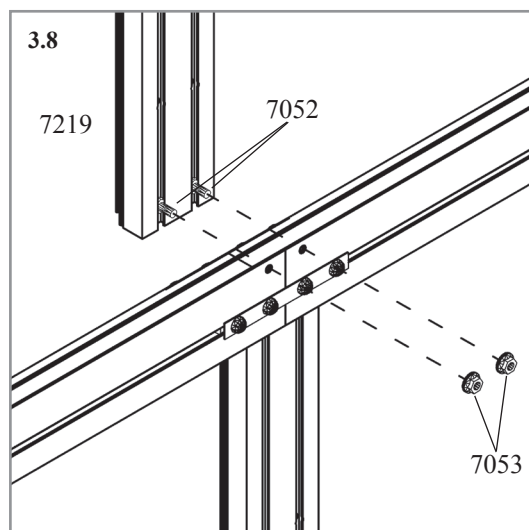
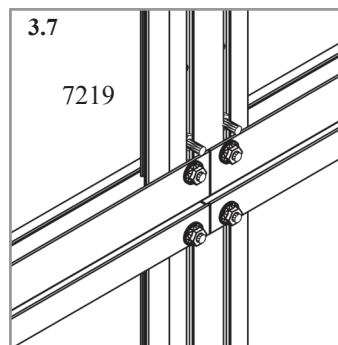
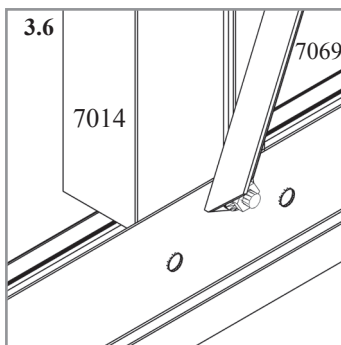

Zwischenprofile

4a

④ a (10000)

4a.1	TEIL 1-TEIL 2	LÄNGE
8100	7250-7250	1520 + 1520 mm
10000	7250-7251	1520 + 2264 mm
11900	7251-7251	2264 + 2264 mm
13800	7251-7252	2264 + 3008 mm
15700	7252-7252	3008 + 3008 mm

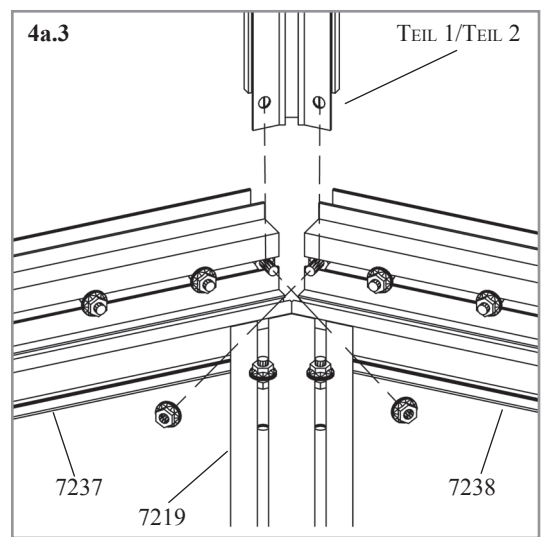
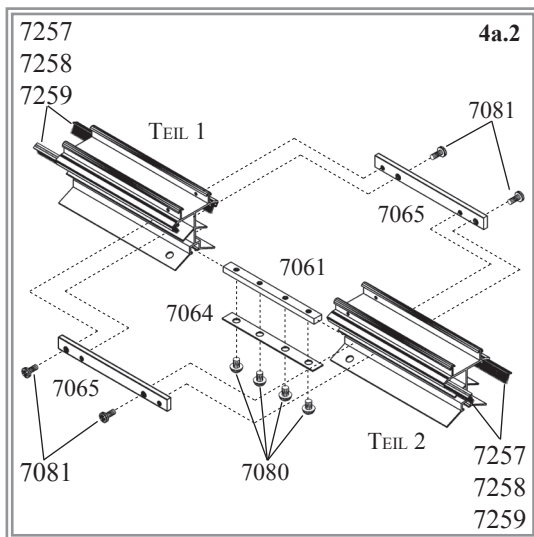
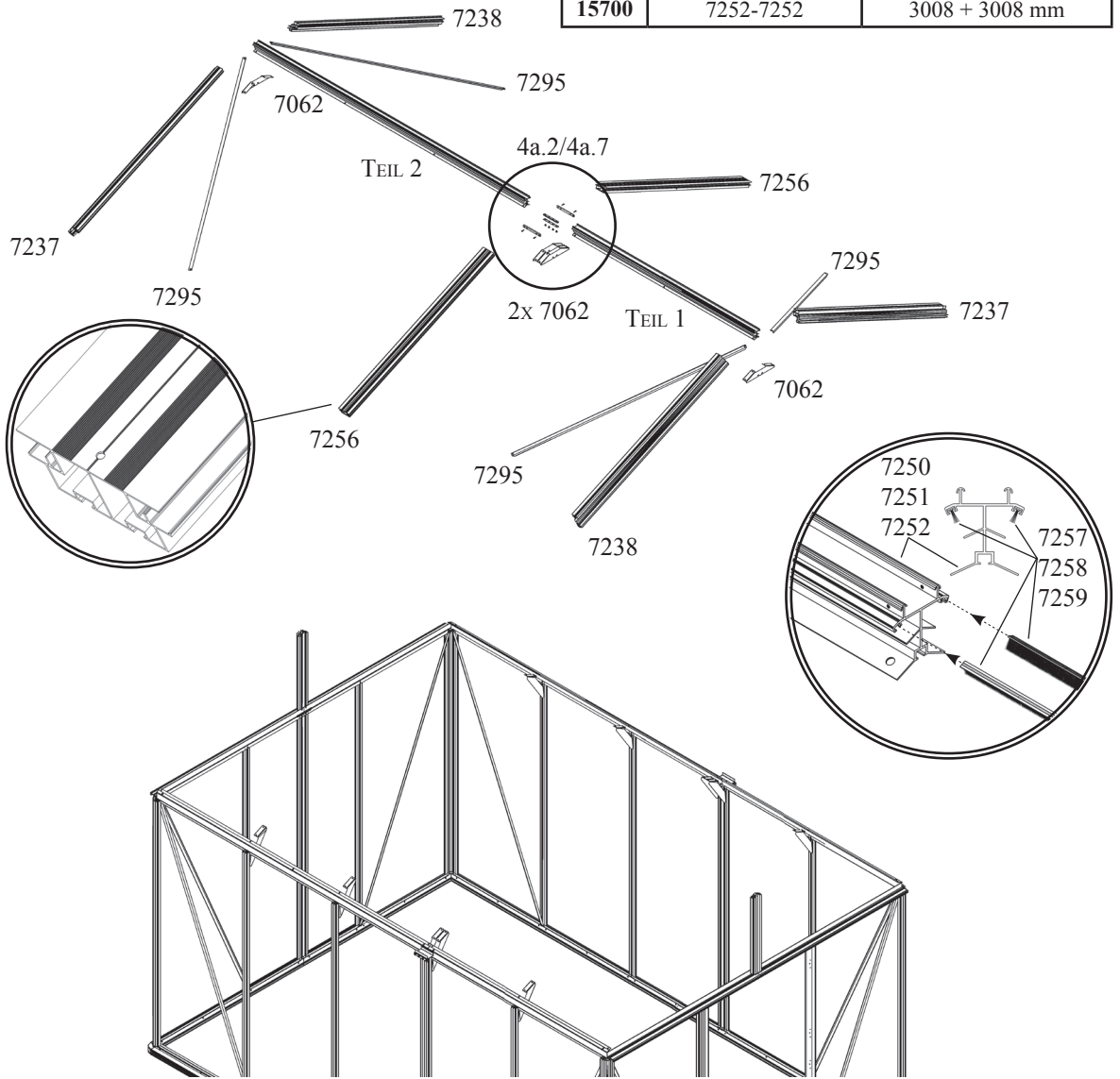

Modell				
8100	10000	11900	13800	15700
7052				
40	40	40	40	40
7053				
40	40	40	40	40
7061				
1	1	1	1	1
7062				
4	4	4	4	4
7064				
1	1	1	1	1
7065				
2	2	2	2	2
7080				
4	4	4	4	4
7081				
4	4	4	4	4
7237				
2	2	2	2	2
7238				
2	2	2	2	2
7250				
2	1	0	0	0
7251				
0	1	2	1	0
7252				
0	0	0	1	2
7256				
2	2	2	2	2
7257				
4	2	0	0	0
7258				
0	2	4	2	0
7259				
0	0	0	2	4
7295				
4	4	4	4	4

ZEUS 2

GIEBEL / FIRST

BITTE BEACHTEN SIE...

In diesem Aufbauschnitt sollten Sie mit 2 oder 3 Personen arbeiten. Sie benötigen eine, besser zwei Leitern.

Einige Muttern 7053 müssen wieder gelöst werden um weitere Profile zu montieren.

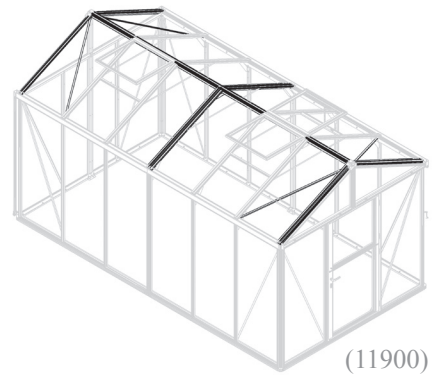

Bereiten Sie den First mit den Firstprofilen (Tabelle 4a.1) für die Endmontage vor. Schieben Sie die Kunststoffbürstendichtungen 7257, 7258 oder 7259, wie in der Abbildung gezeigt, in die Kanäle auf beiden Seiten des Firsts. Verbinden Sie die Firstprofile mit den Firstverbindern 7061/7064/7080 und 7065/7081 (4a.2). Legen Sie den montierten First zur Seite. Führen Sie in die Profile 7237 und 7238 je 2 Leerschrauben 7052 in den Schraubenkanal, der in Richtung Dachfläche zeigt und fixieren diese je mit einer Mutter 7053 (4a.3). Diese werden später zur Montage der Knotenbleche 7062 benötigt. Legen Sie die Profile 7237 und 7238 auf die Firststütze 7219 (4a.3)(4a.4) und verschrauben Sie das Profil zuerst an der Traufe mit den Schrauben 7052 und Muttern 7053.

Jetzt verbinden Sie das vorbereitete Firstprofil mit den Giebelprofilen 7237 und 7238 (4a.5). Montieren Sie jetzt die Knotenbleche 7062 mit den vorbereiteten Leerschrauben in 7219, 7237 und 7238 (4a.6). Anschließend montieren Sie die Diagonalstreben 7295 zwischen First (4a.6) und Traufenwinkel (4a.8). Bereiten Sie jetzt die Dachzwischenprofile 7256 vor, indem Sie je 4 Leerschrauben 7053 mit je einer Mutter 7052 in jedem Schraubenkanal fixieren und montieren diese zwischen First und Traufe (4). Bauen Sie die Dachzwischenprofile 7256 so ein, dass sich das kleine Loch auf der Oberseite am Traufenprofil befindet. Anschließend montieren Sie die Knotenbleche 7062 am First (4a.7) und 7063 an der Traufe (4a.8).

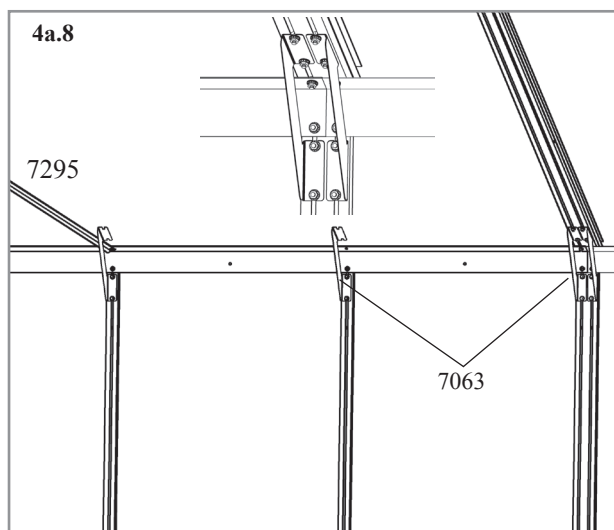
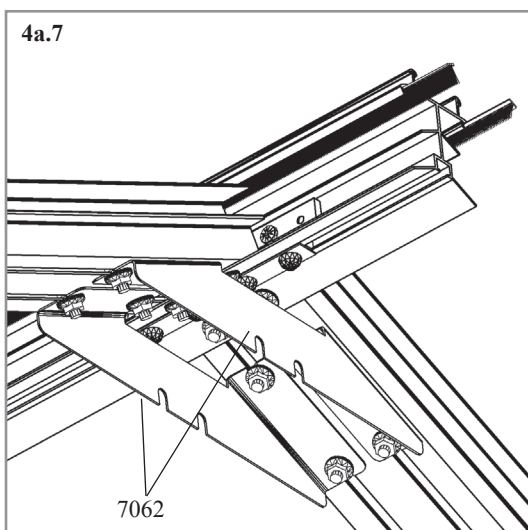
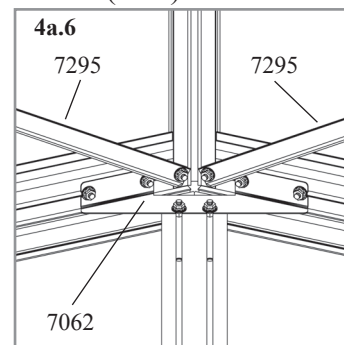
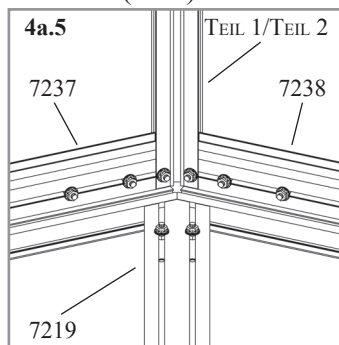
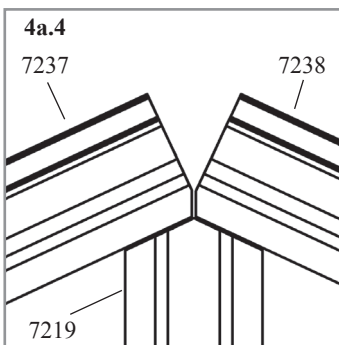

4b

④b (10000)

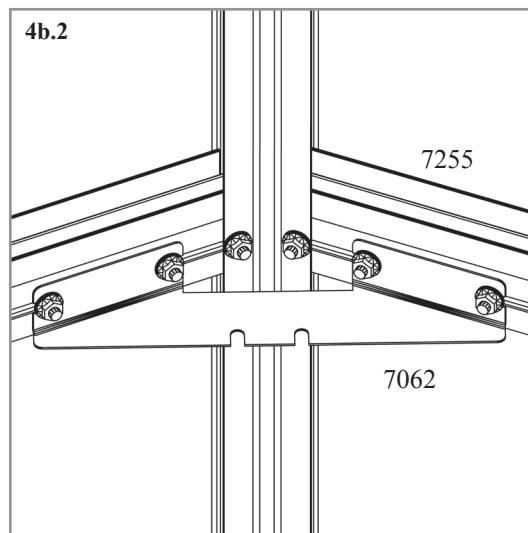
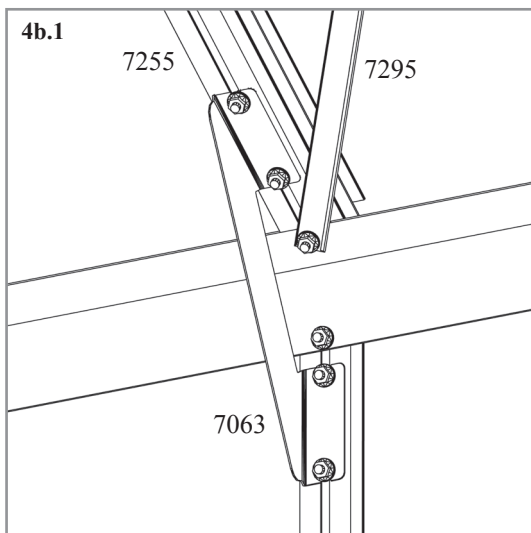
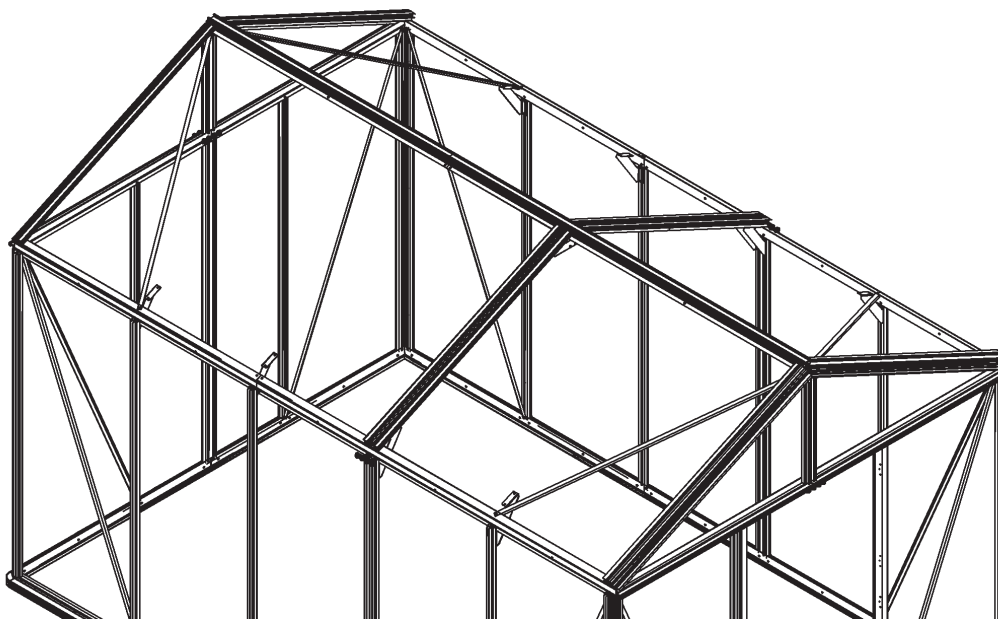
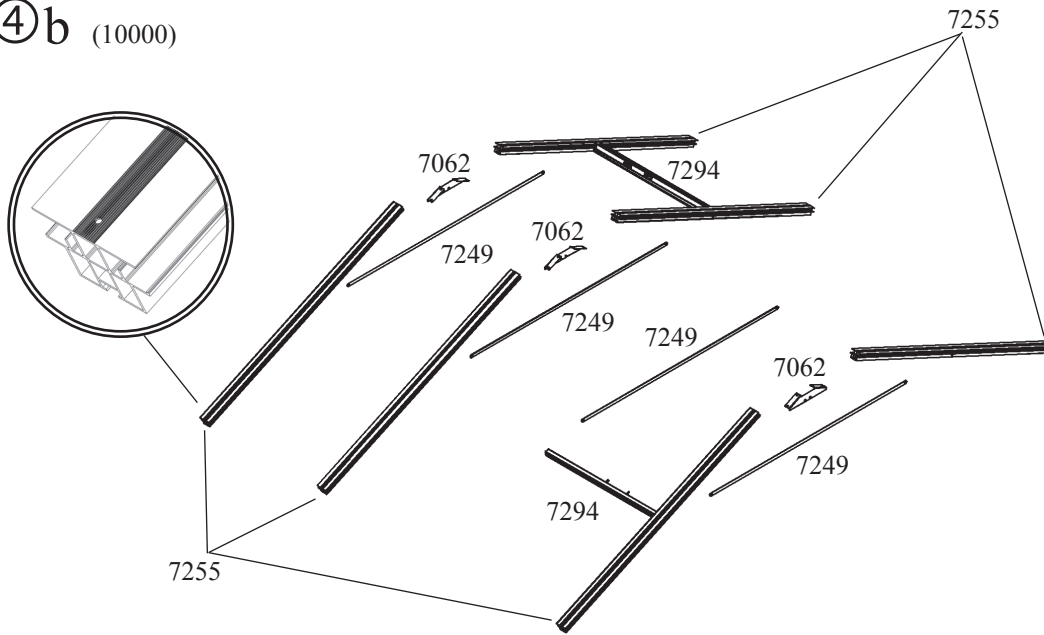

Modell				
8100	10000	11900	13800	15700
1006				
8	8	12	12	12
6056				
4	4	6	6	6
7047				
2	4	4	6	8
7048				
0	1	2	2	2
7052				
24	36	48	60	72
7053				
24	36	48	60	72
7054				
4	4	6	6	6
7055				
4	4	6	6	6
7062				
2	3	4	5	6
7249				
3	4	5	6	7
7255				
4	6	8	10	12
7294				
2	2	3	3	3

DACHZWISCHENPROFILE

BITTE BEACHTEN SIE...

In diesem Aufbauschritt sollten Sie mit 2 oder 3 Personen arbeiten. Sie benötigen eine, besser 2 Leitern.

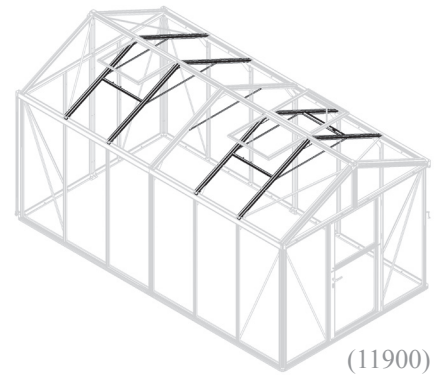

Bereiten Sie die Dachzwischenprofile 7255 vor, indem Sie je 4 Leerschrauben mit je einer Mutter 7053 in jedem Schraubenkanal lose fixieren und montieren diese zwischen First (4b.1) und Traufe (4b.2)(4b). Bauen Sie die Dachzwischenprofile 7255 so ein, dass sich das kleine Loch auf der Oberseite am Traufenprofil befindet. Montieren Sie jetzt die Firstknotenbleche 7062 (4b.2) und die bereits angesetzten Traufenknotenbleche 7063 (4b.1) Mit der Montage der Dachfensterschwelle 7294 und der horizontalen Versteifung 7249 bestimmen Sie die Position der Dachfenster (4b.5) (4b.6). Fenster können beliebig, jedoch nicht im ersten Feld oder direkt nebeneinander kombiniert werden, es muss mindestens ein komplettes Feld dazwischen liegen.

Montieren Sie die restlichen Dachversteifungen 7249 (4b.3)(4b.4).

Nach erfolgter Montage der Profile 7294 können je 2 Einrastzapfen 6056 mit den Schrauben 1006 montiert werden(4b.5)(4b.6).

Dachzwischenprofile

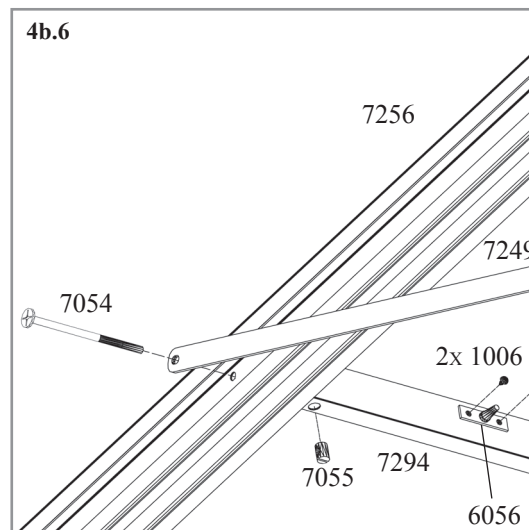
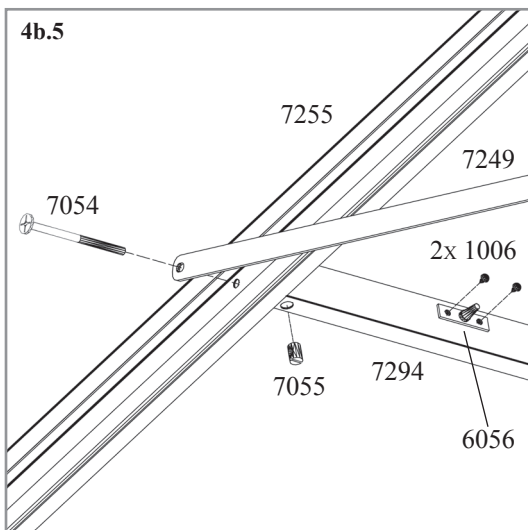
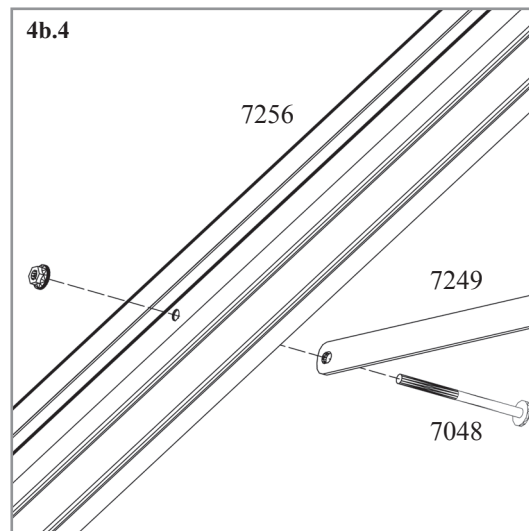
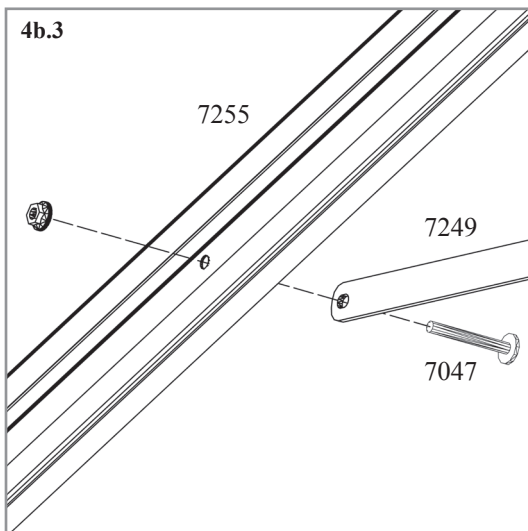

⑤

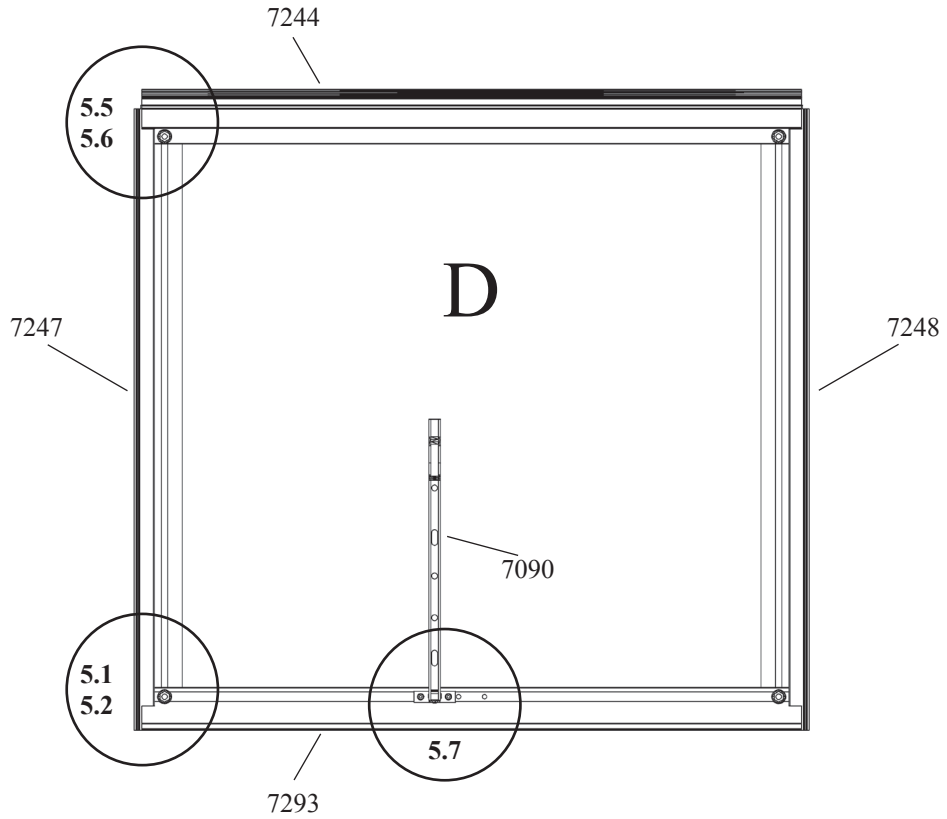

5.1	HOHLKAMMERPLATTEN				Modell				
	10 MM		16 MM		8100	10000	11900	13800	15700
	ART. NR.	MM	ART. NR.	MM					
D	3695744	670 x 660	3695745	645 x 637	2x1	2x1	3x1	3x1	3x1

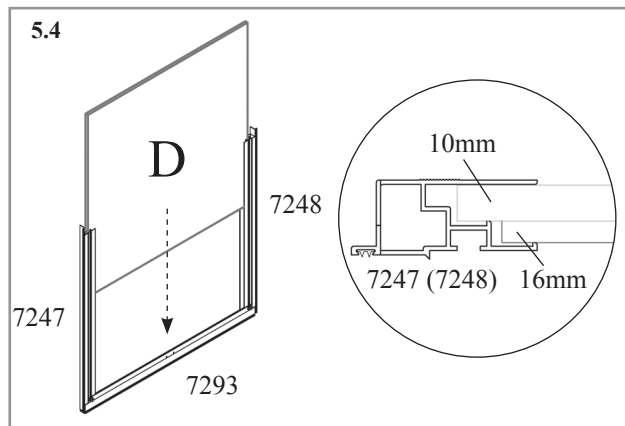
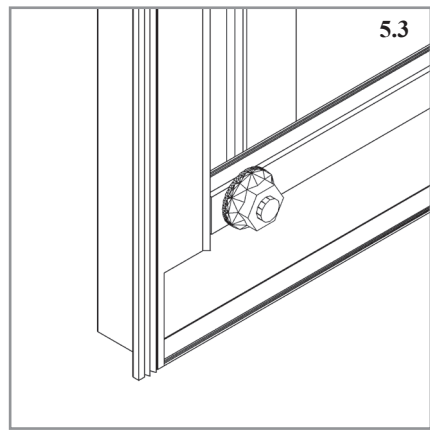
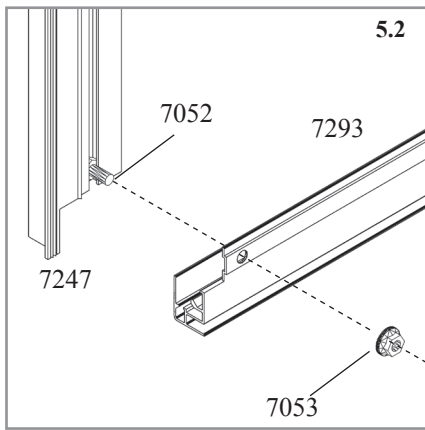

FENSTER

BITTE BEACHTEN SIE...

Bei der Montage des Fensters muss vor der Montage des Scharnierprofils 7244 die Verglasung eingesetzt werden.

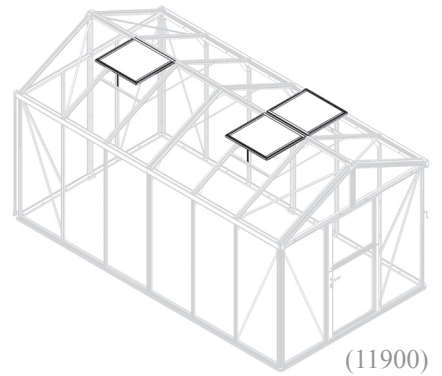

Verbinden Sie zunächst die Profile 7293 und 7247 mit der Schraube 7052 und der Mutter 7053 wie in Abb.5 (5.2)(5.3). Führen Sie dann die Verglasung gemäß Tabelle 5.1 in die Profile ein (5.4).

Bereiten Sie das Profil 7244 vor, indem Sie je 2 Schrauben 7052 und Muttern 7053 lose an beiden Enden befestigen (5.5). Führen Sie die losen Mutterknöpfe 7052 in die Profile 7247 und 7248 ein, um den Rahmen 7244 zu verschließen (5.5-5.6). Achten Sie auf die rechtwinklige Montage des Fensters bevor Sie alle Schrauben festziehen. **Bitte die Schrauben nicht zu fest ziehen.** Abschließend montieren Sie den Fensteraufsteller 7090 mit den Schrauben 1006 an dem unteren Fensterprofil 7293 (5.7).

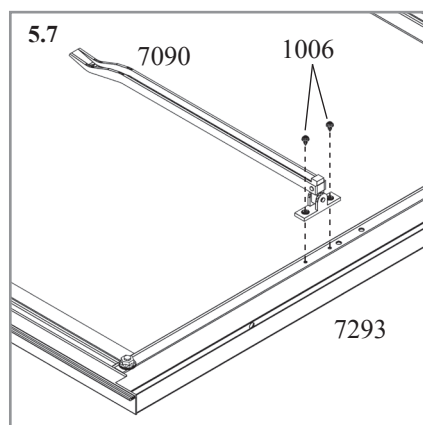
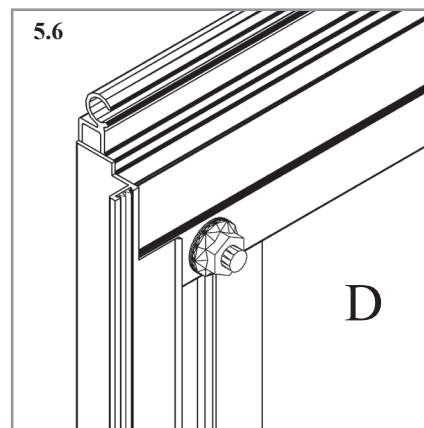
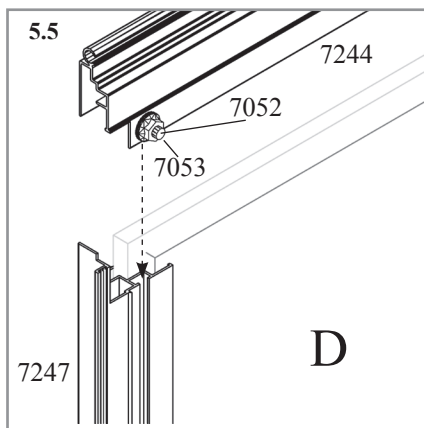

OBERE TÜR

BITTE BEACHTEN SIE...

Die Verglasung der Türelemente erfolgt zu einem späteren Zeitpunkt in Schritt 7 c.

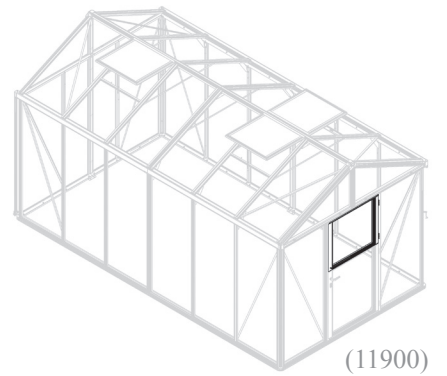

Führen Sie in die Profile 7017 und 7018 je eine Leerschraube 7052 und Mutter 7053 ein wie in Abb. 6 gezeigt. Um die vertikalen und horizontalen Profile miteinander zu verbinden, fügen Sie Quermutterbolzen 7055 in die Profile 7022 und schieben Sie die Schrauben 7054 durch die Seitenprofile (6a.1) (6a.2). Beachten Sie die Löcher zur Befestigung des Türriegels 7085. Befestigen Sie die Abdeckprofile 7024 unten (6a.2) und 7025 oben mit 6 Schrauben 1006 (6a.3). Schieben Sie eine zusätzliche Schraube 7052 in den Schraubenkanal beider Seitenprofile 7017 und 7018. Montieren Sie das obere Abdeckprofil 7025 mit den Schrauben, Türstützen 7114 und 4 Schrauben 1006 (6a.4). Ziehen Sie die Türdichtung 7083 in das obere Abdeckprofil 7025 (6a.5). Schrauben Sie den Türriegel 7085 mit den Schrauben 7087 an das vertikale Türprofil 7018 (6a.6) und die Scharniere 7066 mit den Schrauben 7088 an das vertikale Türprofil 7017 (6a.7).

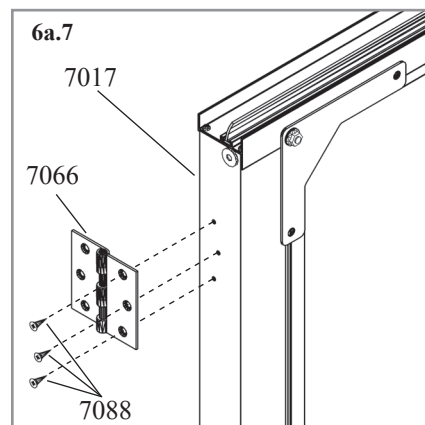
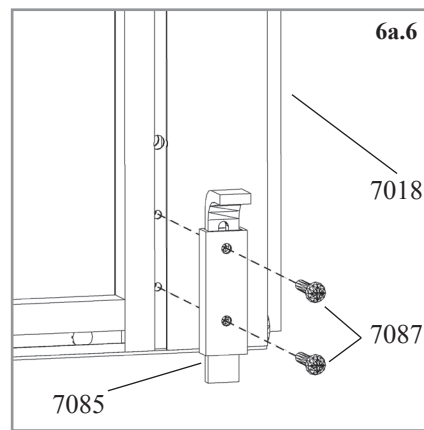
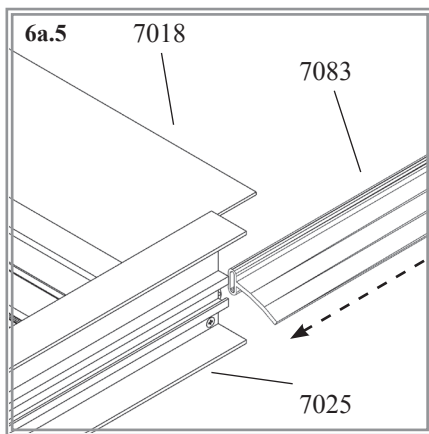

Obere Tür

6b

⑥b

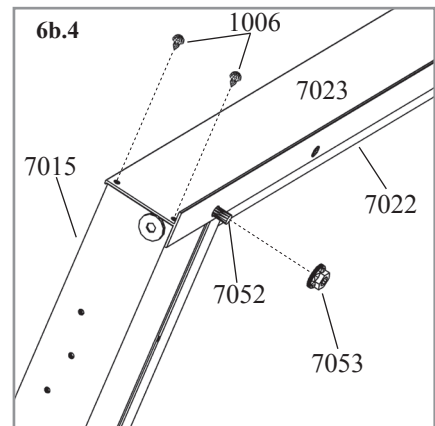
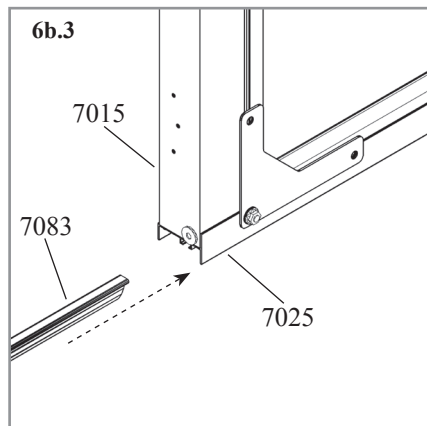
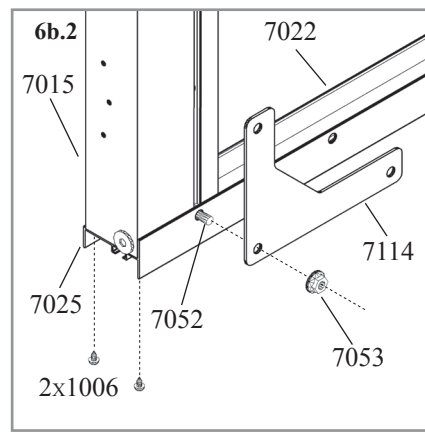
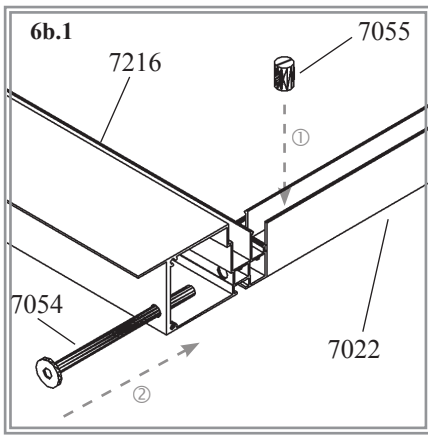
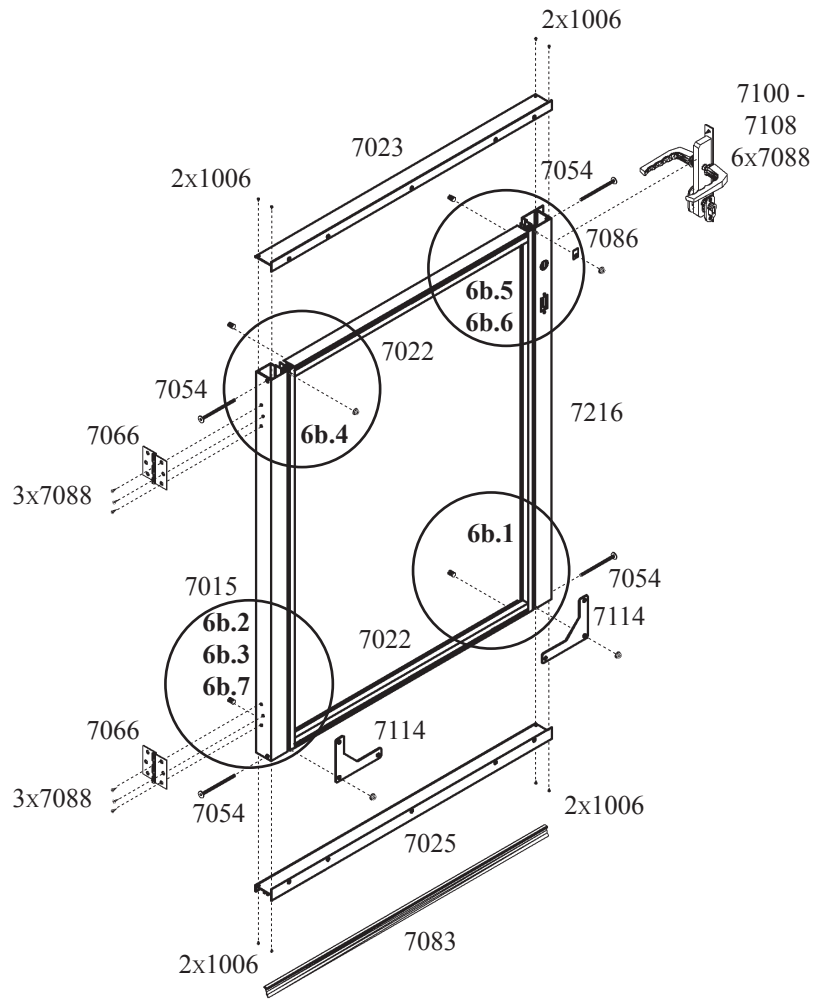

Alle Modelle	
1006 x8	
7015 x1	
7022 x2	
7023 x1	
7025 x1	
7052 x4	
7053 x4	
7054 x4	
7055 x4	
7066 x2	
7083 x1	
7086 x1	
7088 x12	
7100 x1	
7101 x1	
7102 x1	
7103 x2	
7104 x2	
7106 x2	
7107 x1	
7108 x2	
7114 x2	
7216 x1	

ZEUS 2

UNTERE TÜR





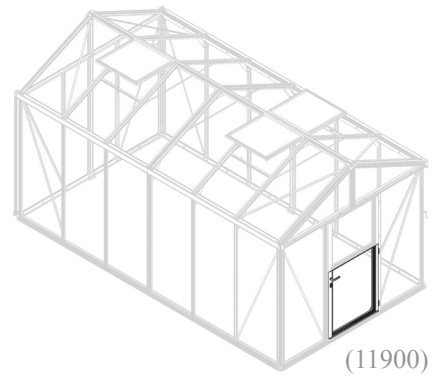

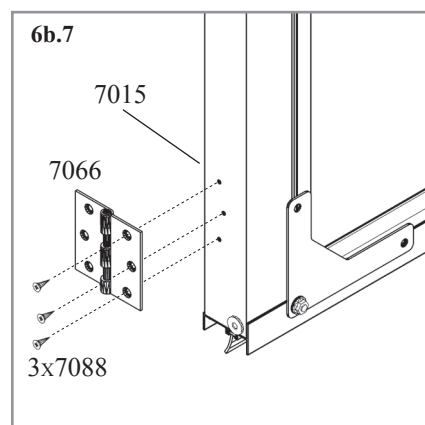
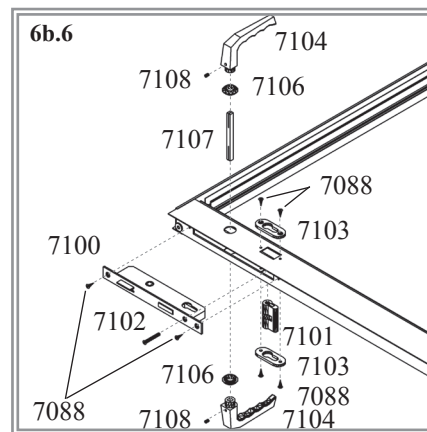
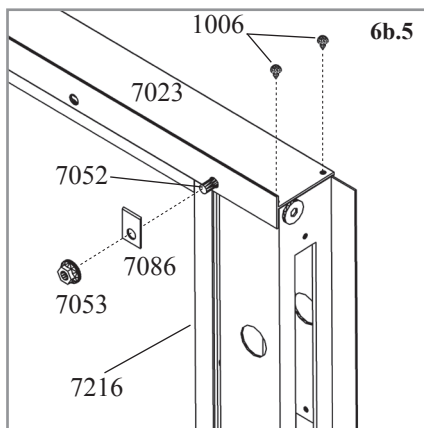

BITTE BEACHTEN SIE...









Die Verglasung der Türelemente erfolgt zu einem späteren Zeitpunkt (Schritt 7c).



Führen Sie in die Profile 7015 und 7216 je 2 Leerschrauben 7052 und Muttern 7053 ein, wie in 6b gezeigt. Um die vertikalen und horizontalen Profile miteinander zu verbinden, fügen Sie die Quermutterbolzen 7055 in die Profile 7022 ein und schieben Sie die Schrauben 7054 durch die Seitenprofile (6b.1)(6b.2). Führen Sie 2 zusätzliche Schrauben 7052 in den Schraubenkanal beider Seitenprofile 7015 und 7216 ein (5b.2)(6b.4)(6b.5). Montieren Sie das untere Abdeckprofil 7025 mit den Schrauben, Türstützen 7114 und 4 Schrauben 1006 (6b.2). Ziehen Sie die Türdichtung 7083 in das untere Abdeckprofil 7025 ein (6b.3). Montieren Sie das obere Abdeckprofil 7023 mit den Schrauben 7052 und 4 Schrauben 1006. Zusätzlich verbinden Sie die Türriegelplatte 7086 mit dem Seitenprofil 7216 und dem Abdeckprofil 7023 und fixieren es mit den Schrauben 7053 (6b.5). Montieren Sie das Schloss 7100 bis 7108 mit den Schrauben 7088 (6b.6) Schrauben Sie die Scharniere 7066 mit den Schrauben 7088 an das Seitenprofil 7015 (6b.7).



7.1	HOHLKAMMERPLATTE						STÜCKZAHL/MODELL				
	6 MM (DACH 10MM)		10 MM		16 MM		8100	10000	11900	13800	15700
	ART. No.	MM	ART. No.	MM	ART. No.	MM					
A 	3695711	725 x 1790	3695712	725 x 1790	3695713	725 x 1790	12	14	16	18	20
B 	3695726	725 x 1368	3695726	725 x 1368	3695727	710 x 1368	6	8	9	11	13
C 	3695736	725 x 699	3695736	725 x 699	3695737	710 x 691	2	2	3	3	3
D 	3695744	670 x 660	3695744	670 x 660	3695745	645 x 637	2	2	3	3	3
E 	3695751	725 x 966	3695752	725 x 966	3695753	725 x 966	1	1	1	1	1
F 	3695761	725 x 683	3695762	725 x 683	3695763	725 x 683	1	1	1	1	1
G 	3695771	1190x567/15	3695772	1190x567/15	3695773	1190x567/15	2	2	2	2	2
H 	3695781	1190x567/15	3695782	1190x567/15	3695783	1190x567/15	2	2	2	2	2
J 	3695791	435 x 1790	3695792	435 x 1790	3695793	435 x 1790	2	2	2	2	2
TOTAL							30	34	39	43	47

7.2	GLAS / HOHLKAMMERPLATTE		STÜCKZAHL/MODELL				
	4 MM / 10MM		8100	10000	11900	13800	15700
	ART. No.	MM					
A 	367801	725 x 1790	12	14	16	18	20
B 	3695726	725 x 1368 x 10	6	8	9	11	13
C 	3695736	725 x 699 x 10	2	2	3	3	3
D 	3695744	670 x 660 x 10	2	2	3	3	3
E 	367805	725 x 966	1	1	1	1	1
F 	367806	725 x 683	1	1	1	1	1
G 	367807	1190x567/15	2	2	2	2	2
H 	367808	1190x567/15	2	2	2	2	2
J 	367809	435 x 1790	2	2	2	2	2
TOTAL			30	34	39	43	47

VERGLASUNG ÜBERSICHTSPLAN

BITTE BEACHTEN SIE...

In diesem Aufbauschnitt sollten Sie mit 2-3 Personen arbeiten. Beim Einsetzen der Verglasung bitte Schutzhandschuhe, Schutzbrille, Sicherheitsschuhe und Kopfschutz tragen! Beachten Sie die vorgegebene Reihenfolge der Verglasung (7a-7b-7c). Bei den Hohlkammerplatten ist die Außenseite mit einer Folie und/oder einer seitlichen Kennzeichnung versehen.

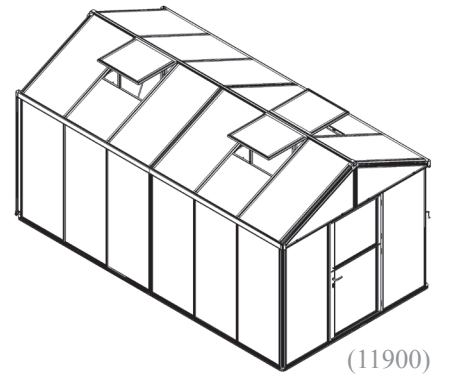

Sortieren Sie die Verglasung gemäß dem Übersichtsplan je nach Modell und der Tabelle 7.1 oder 7.2 bevor Sie beginnen.



Die UV-beständige Seite der Hohlkammerplatten ist durch eine Folie oder einen gedruckten Hinweis an den Kanten gekennzeichnet. **Diese Seite muss nach außen zeigen!** Lösen Sie die Folie ca. 2 cm an jeder Seite, bevor Sie die Scheibe einsetzen und entfernen Sie die Folie nach erfolgter Montage vollständig.

Verglasung Übersichtsplan

Modell				
8100	10000	11900	13800	15700
A				<input type="checkbox"/>
12	14	16	18	20
B				<input type="checkbox"/>
6	8	9	11	13
C				<input type="checkbox"/>
2	2	3	3	3
E				<input type="checkbox"/>
1	1	1	1	1
F				<input type="checkbox"/>
1	1	1	1	1
G				<input type="checkbox"/>
2	2	2	2	2
H				<input type="checkbox"/>
2	2	2	2	2
J				<input type="checkbox"/>
2	2	2	2	2

(8100)

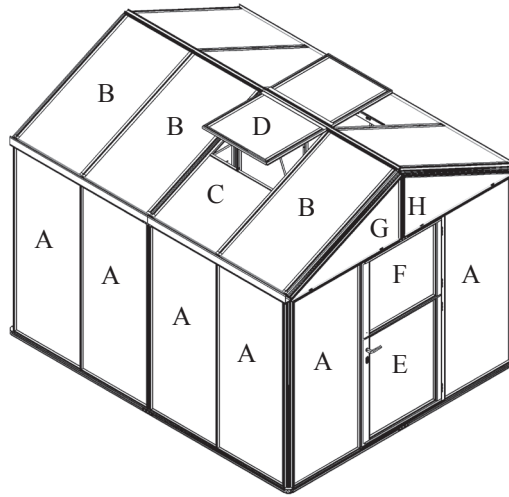

(10000)

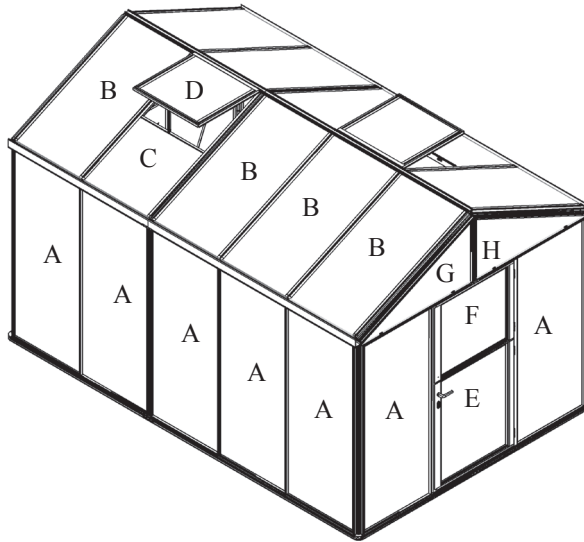

(11900)

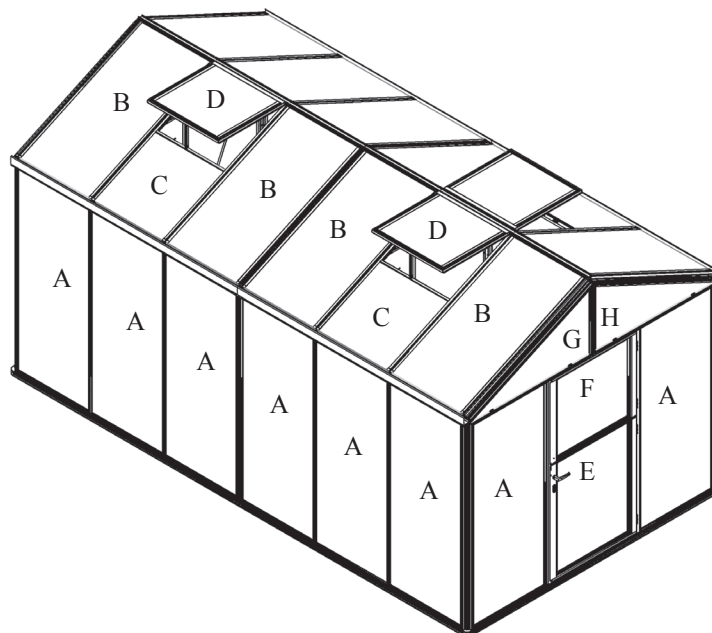

(13800)

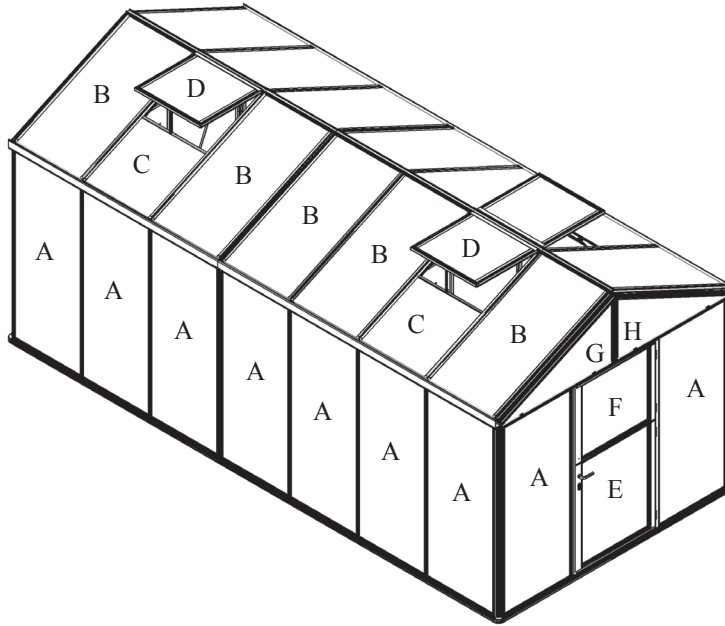

(15700)

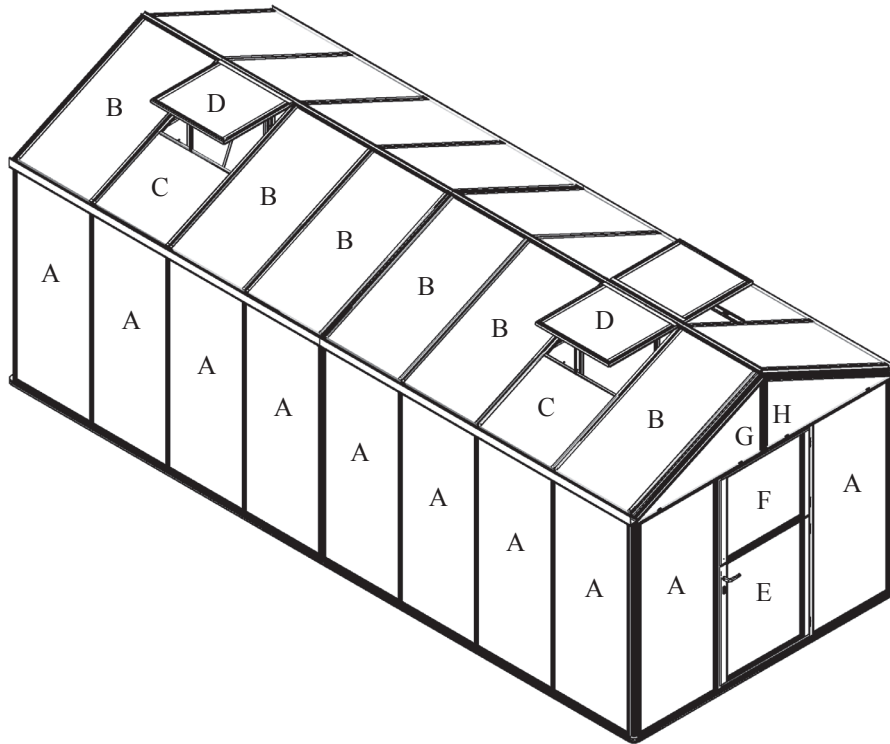

Rückwand - Alle Modelle

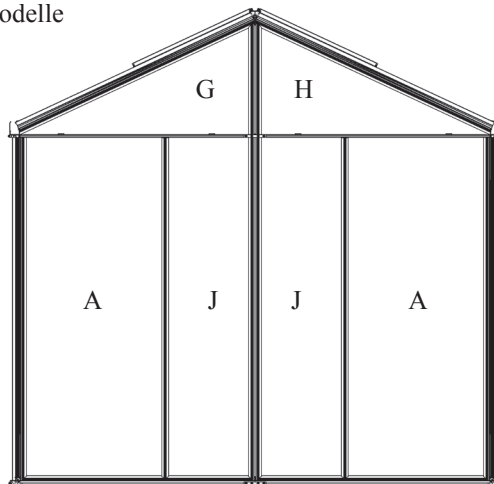

Verglasung Übersichtsplan

7a

(10000)

7a.1	TEIL 1-TEIL 2	LÄNGE
8100	7213-7213	1539 + 1539 mm
10000	7213-7214	1539 + 2283 mm
11900	7214-7214	2283 + 2283 mm
13800	7214-7215	2283 + 3027 mm
15700	7215-7215	3027 + 3027 mm

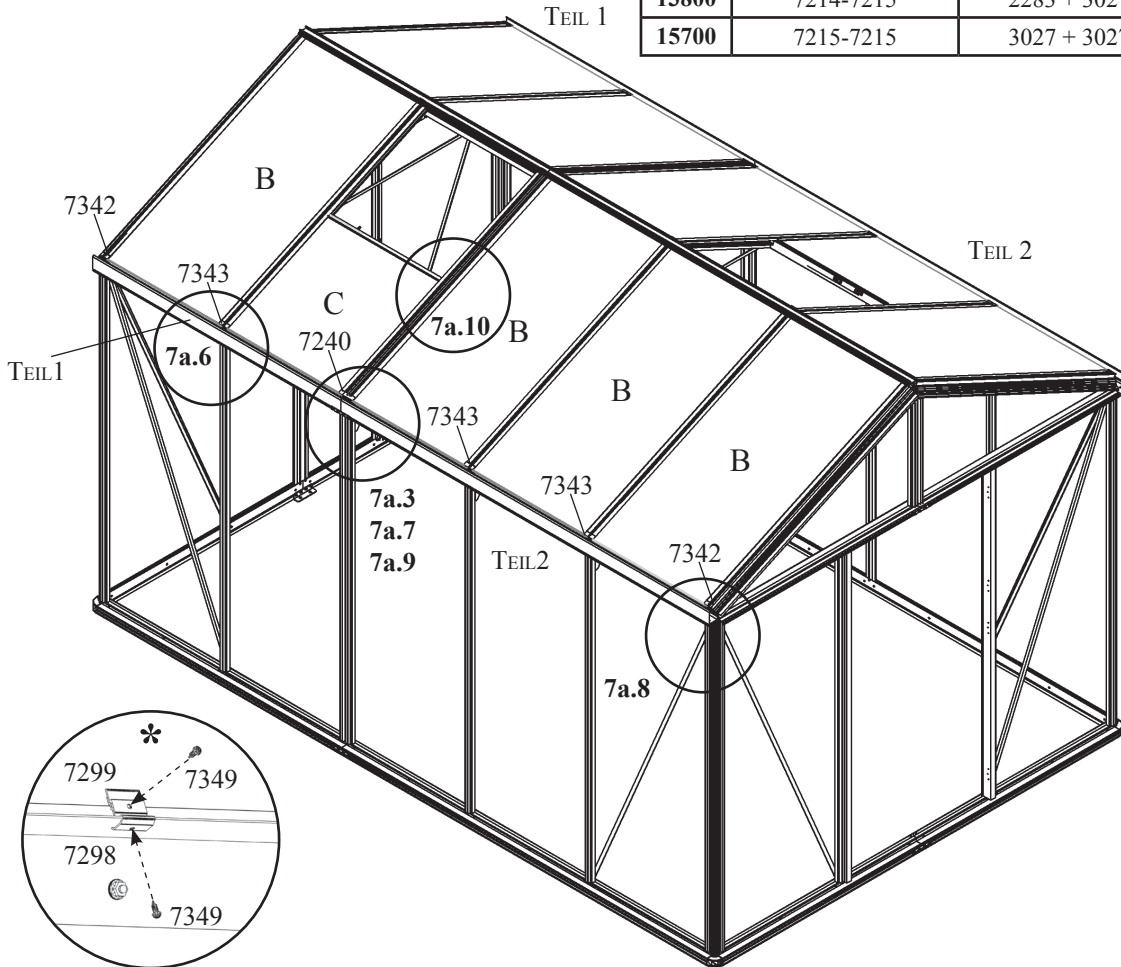

Modell				
8100	10000	11900	13800	15700
7052				
8	10	12	14	16
7053				
8	10	12	14	16
7061				
2	2	2	2	2
7064				
2	2	2	2	2
7080				
8	8	8	8	8
7213				
4	2	0	0	0
7214				
0	2	4	2	0
7215				
0	0	0	2	4
7240				
2	2	2	2	2
7292				
2	2	2	2	2
7296				
8	10	12	14	16
7297				
8	10	12	14	16
7342				
4	4	4	4	4
7343				
4	6	8	10	12
7349				
34	42	50	58	66
7298*				
8	10	12	14	16
7299*				
8	10	12	14	16

7a.2	HOHLKAMMERPLATTE				STÜCKZAHL/MODELL				
	10 MM		16 MM		8100	10000	11900	13800	15700
	ART. NO.	MM	ART. NO.	MM					
B	3695726	725 x 1368	3695727	710 x 1368	6	8	9	11	13
C	3695736	725 x 699	3695737	710 x 691	2	2	3	3	3

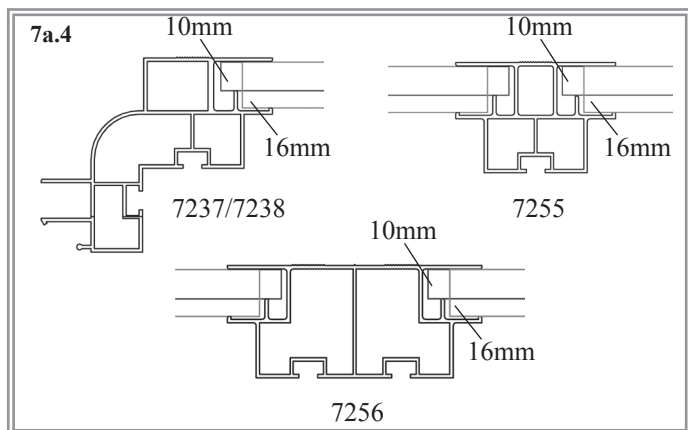
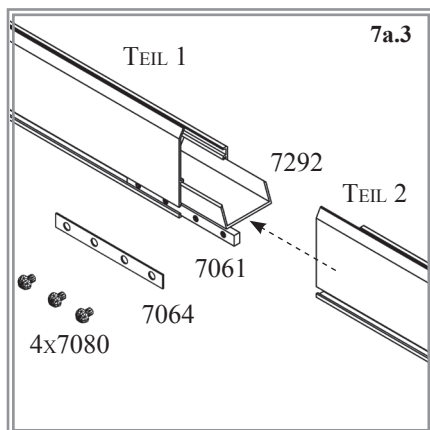

DACHVERGLASUNG / TRAUFE

BITTE BEACHTEN SIE...

In diesem Aufbauschritt sollten Sie mit 2, besser mit 3 Personen arbeiten.

Beim Einsetzen der Verglasung bitte Schutzhandschuhe Schutzbrille, Sicherheitsschuhe und Kopfschutz tragen!

Beachten Sie die vorgegebene Reihenfolge der Verglasung.

Bei den Hohlkammerplatten ist die Außenseite mit einer Folie und / oder einer seitlichen Kennzeichnung versehen.

Montieren Sie die Traufen gemäß Tabelle 7a.1. Verbinden Sie diese durch Einschieben der Verbindungsleiste 7061 in die Kanäle der Traufenprofile und befestigen Sie diese mit den Traufenverbindern 7064 und Schrauben 7080. Vergewissern Sie sich, dass der Kunststoffverbinder 7292 mittig an der Verbindung sitzt (7.3). Führen Sie die Dachverglasung in die Führungsschienen der Dachprofile ein (7a.4). Wenn 2 Scheiben nebeneinanderliegend platziert sind, Verglasungsstopps 7240, 7342 oder 7343 in die Dachprofile schrauben mit Hilfe der vorgebohrten Löcher und selbstschneidenden Schrauben 7349 (7a.6). Die Scheiben sollten bis zu den Stopps herunterrutschen. Schieben Sie Glasabstandshalter 7296 über die Innenkante des Traufenwinkels (7a.7). Bei 10 mm Verglasung platzieren Sie den Abstandshalter 7297 in der Fuge in 7296, auf der die Scheibe aufliegt. Fixieren Sie diese mit Hilfe der vorgebohrten Löcher und Schrauben 7349 (7a.9b).

In den Dachfensterfeldern schieben Sie die Scheibe C in die Profilverführungen 7294 (7a.10). Richten Sie das Traufenprofil bei der Montage in Richtung Traufenwinkel aus (7a.8) und drücken Sie es nach unten gegen den Traufenwinkel. Befestigen Sie es am Traufenwinkel mit den Schrauben 7052 von außen und Muttern 7053 von innen (7a.9).

** Die Bildung von Kondenswasser ist in einem Gewächshaus mit Hohlkammerplatten unvermeidlich. Sie kann aber verringert werden durch Austausch der Teile (7296 / 7297) mit (7298 / 7299). Dies hätte eine erhöhte Ventilation im Innenbereich zur Folge und dadurch würde die Bildung von Kondenswasser reduziert werden.*

Bitte (7298 / 7299) mit den Schrauben (7349) in der Mitte eines jeden Feldes montieren.

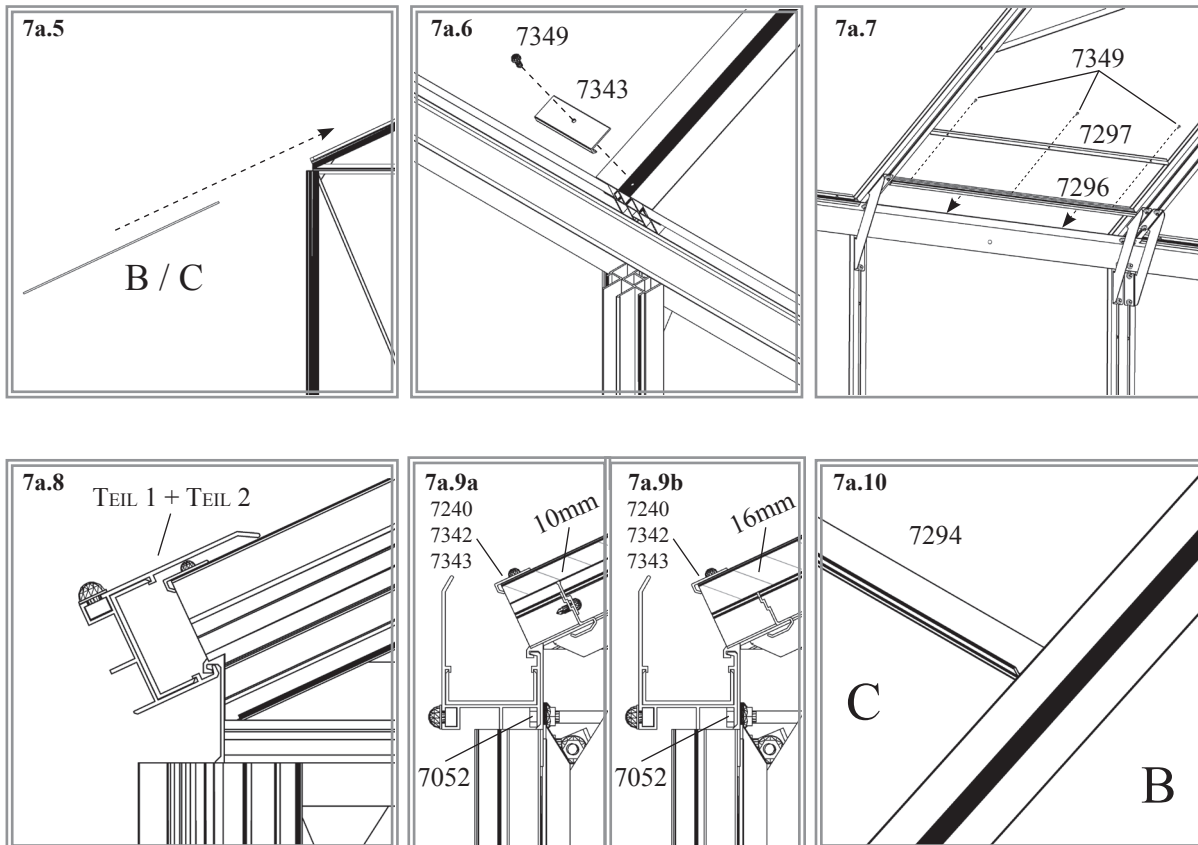
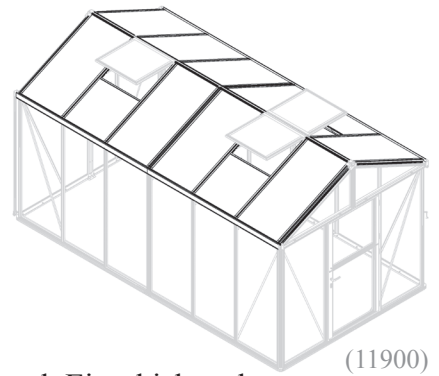

7b

(10000)

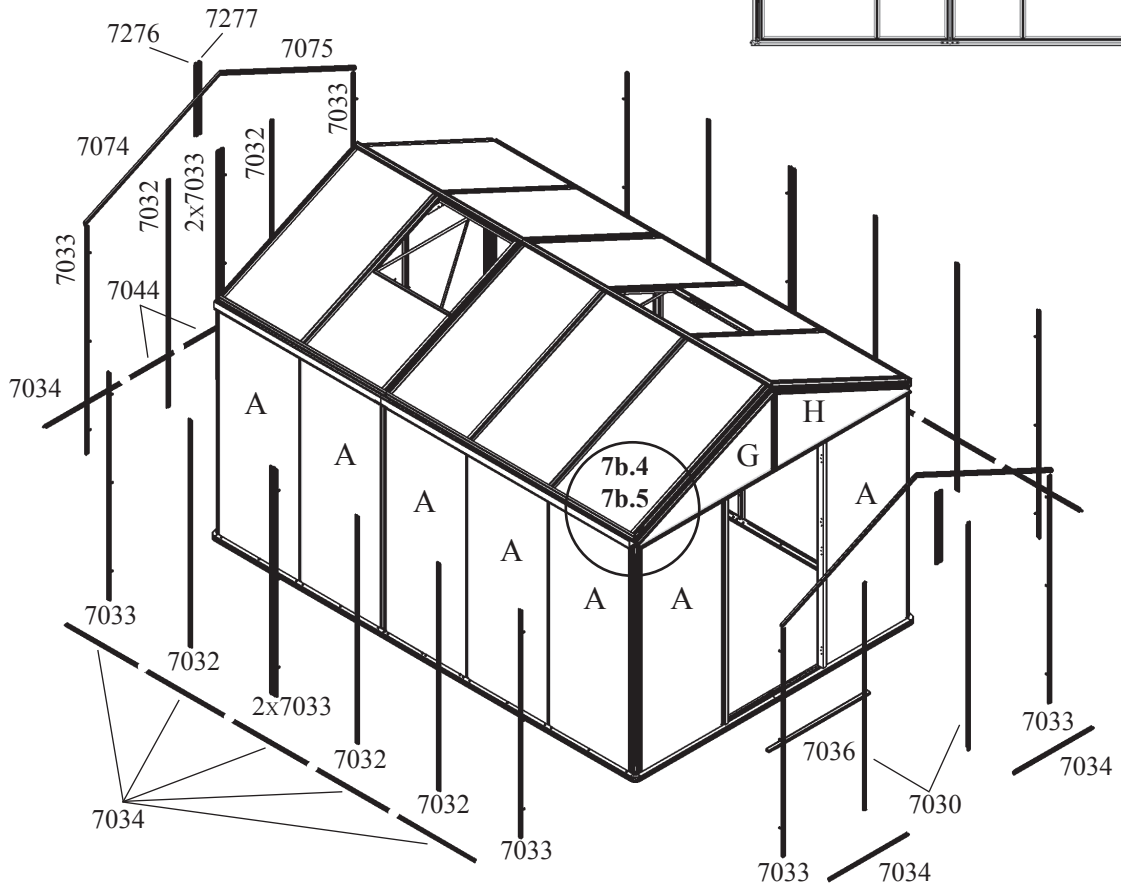
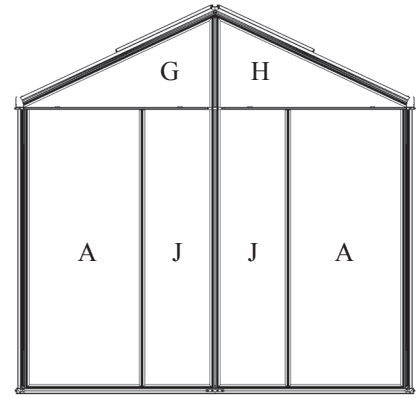
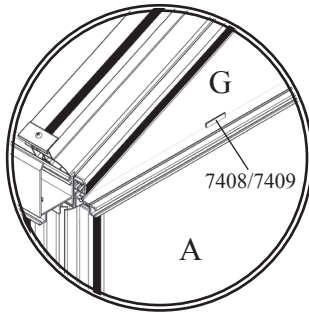

Modell				
8100	10000	11900	13800	15700
6090				
1	1	1	1	1
7030				
2	2	2	2	2
7032				
6	8	10	12	14
7033				
14	14	14	14	14
7034				
12	14	16	18	20
7036				
1	1	1	1	1
7044				
2	2	2	2	2
7050				
126	138	150	162	174
7053				
130	142	154	166	178
7074				
2	2	2	2	2
7075				
2	2	2	2	2
7276				
2	2	2	2	2
7277				
2	2	2	2	2
7390				
4	4	4	4	4
7406				
14	16	18	20	22
7407				
14	16	18	20	22
7408				
8	8	8	8	8
7409				
8	8	8	8	8

7b.1	GLAS	HOHLKAMMERPLATTE				STÜCKZAHL/MODELL					
		4 MM	6 MM	10 MM	16 MM	MM	8100	10000	11900	13800	15700
		ART. NO.	ART. NO.	ART. NO.	ART. NO.		8100	10000	11900	13800	15700
A		367801	3695711	3695712	3695713	725 x 1790	12	14	16	18	20
G		367807	3695771	3695772	3695773	1190x567/15	2	2	2	2	2
H		367808	3695781	3695782	3695783	1190x567/15	2	2	2	2	2
J		367809	3695791	3695792	3695793	435 x 1790	2	2	2	2	2

VERGLASUNG / SEITE

BITTE BEACHTEN SIE...

In diesem Aufbauschnitt sollten Sie mit 2-3 Personen arbeiten. Beim Einsetzen der Verglasung bitte Schutzhandschuhe, Schutzbrille, Sicherheitsschuhe und Kopfschutz tragen! Beachten Sie die vorgegebene Reihenfolge der Verglasung (7a-7b-7c). Bei den Hohlkammerplatten ist die Außenseite mit einer Folie und/oder einer seitlichen Kennzeichnung versehen.

Für 4 mm Glas wird die Glasdichtung 6090 benötigt. Bei Hohlkammerplattenverglasung wird diese nicht benötigt. Abstandhalter 7406 – 7409 werden für Glas oder 16 mm Hohlkammerplatten nicht benötigt.

Beginnen Sie, indem Sie 4 Schrauben 7390 in das Türschwellenprofil 7036 einführen. Verbinden Sie das Profil 7036 von außen, in der Türöffnung, mit den Schwellenprofilen 7003 und 7004. Bei Verglasung mit 4 mm starkem Glas drücken Sie die Glasdichtung 6090 auf die Aluminiumprofile (7b.2) und schneiden Sie sie auf Länge. Durch Einführen der Schrauben 7050 in verschiedene Führungsschienen der Abdeckkappen ist es möglich, das Gewächshaus mit 4 mm, 6 mm, 10 mm oder 16 mm starken Scheiben einzuglasen (7b.2). Führen Sie 3 Schrauben 7050 in jede Abdeckkappe ein wie in (7b.3) gezeigt. Für die Abdeckkappen 7044 benötigen Sie nur 2 Schrauben 7050. Bringen Sie einen Abstandhalter (6 mm 7406/ 10 mm 7407) in der Mitte / an der Oberkante der Scheibe A oder J (7b.4a)(7b.4b). Führen Sie jede Glasscheibe A oder J in den Rahmen ein und verschrauben Sie die vertikalen Abdeckkappen lose mit den Schrauben 7053. Heben Sie die Scheibe 15 mm an und befestigen Sie die Abdeckkappen 7034 oder 7044 lose unter der Scheibe. Bringen Sie 2 Abstandhalter (6 mm 7408, 10 mm 7409) jeweils auf 7010 und 7011 an (7b.5a)(7b.5b). Stellen Sie die Scheiben G und H auf die Abstandshalter und befestigen Sie die Abdeckkappen 7074, 7075, 7276 und 7277 lose. Kontrollieren Sie, ob das Gewächshaus absolut rechtwinklig ist, bevor Sie alle Schrauben fest anziehen! **Bitte nicht zu fest anziehen!**



Die vertikalen Abdeckkappen können am besten montiert werden, wenn zuerst die untere Schraube, danach die mittlere und zum Schluss die oberste Schraube eingeführt werden. Vergewissern Sie sich, dass die Abdeckkappe Kontakt mit dem Schwellenprofil behält.

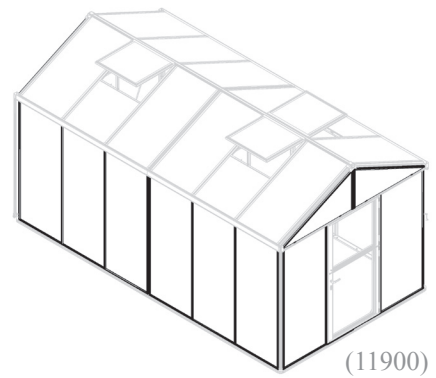

(11900)

Verglasung Seite

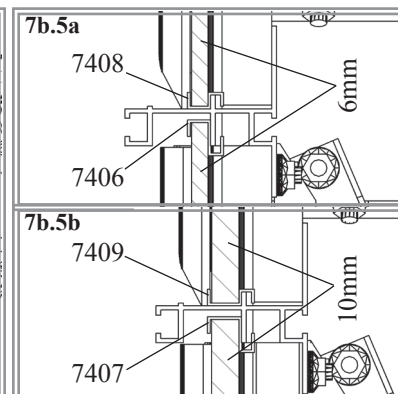
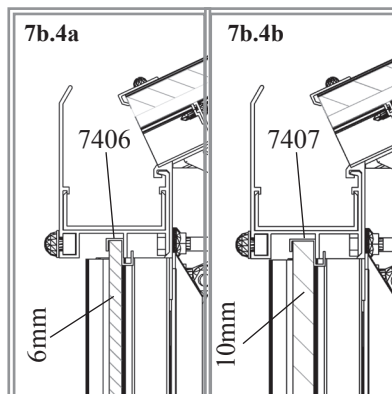
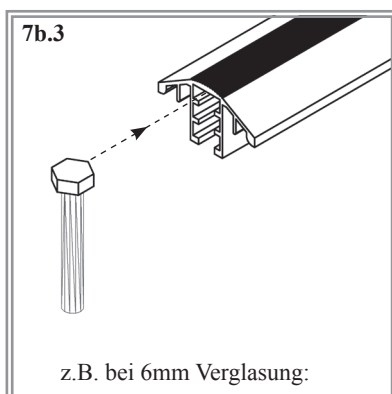
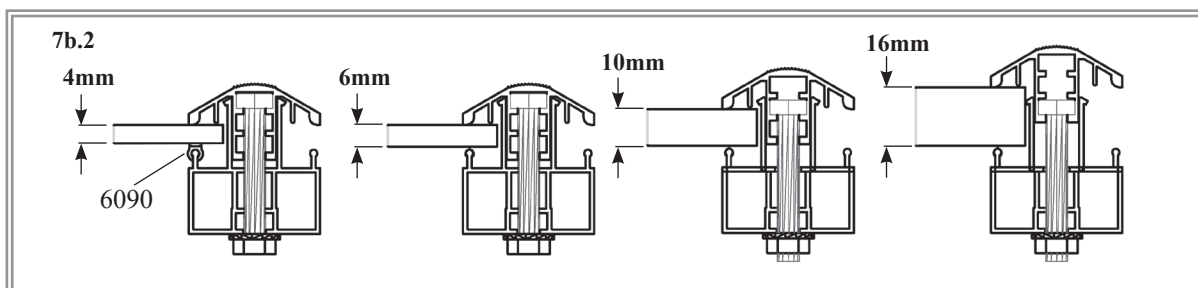

7c

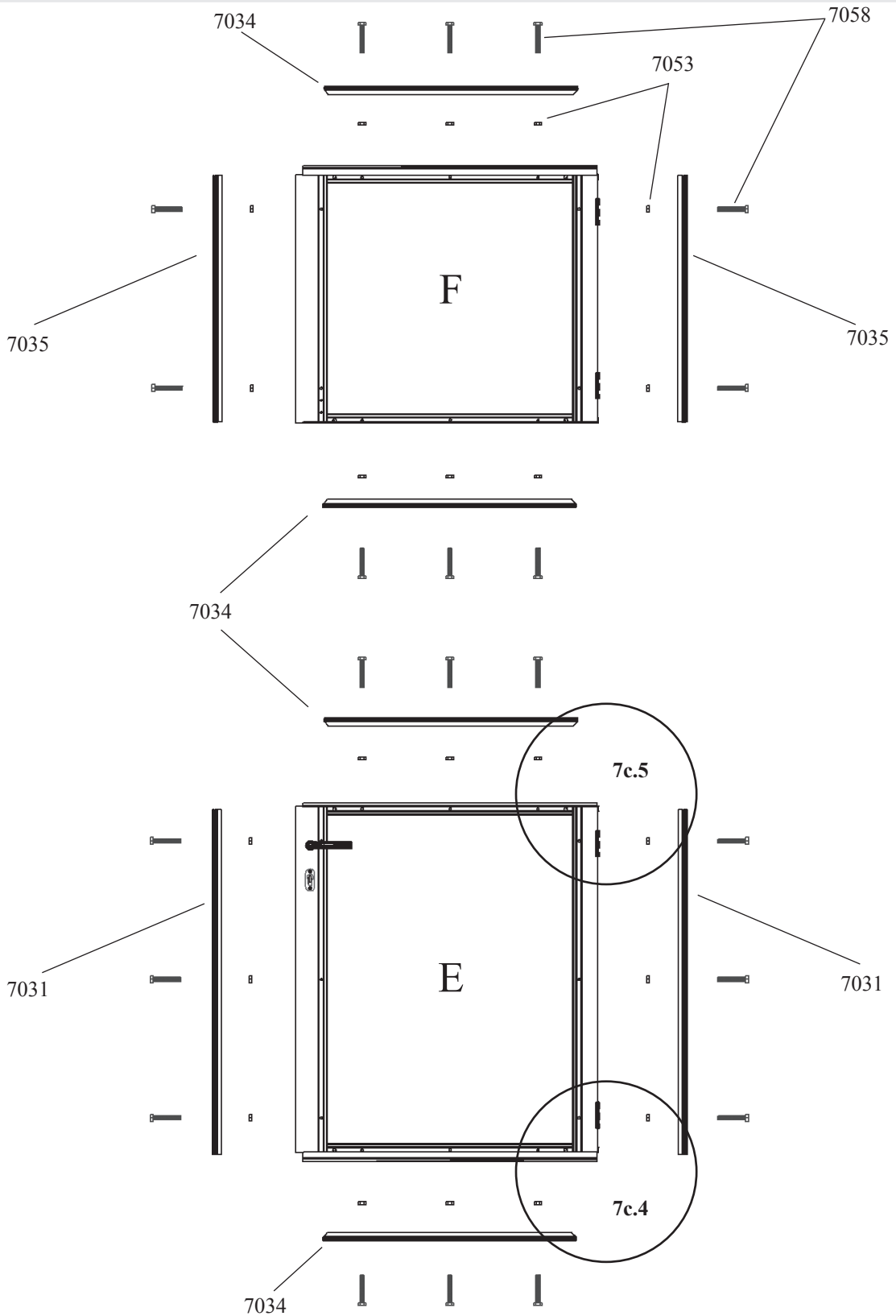

Alle Modelle	
6090 x1	
7031 x2	
7034 x4	
7035 x2	
7053 x22	
7058 x22	
E x1	
F x1	

7c.1	GLAS	HOHLKAMMERPLATTE				STÜCKZAHL/MODELL				
	4 MM	6 MM	10 MM	16 MM	MM	8100	10000	11900	13800	15700
	ART. No.	ART. No.	ART. No.	ART. No.						
E <input type="checkbox"/>	367805	3695751	3695752	3695753	725 x 966	1	1	1	1	1
F <input type="checkbox"/>	367806	3695761	3695762	3695763	725 x 683	1	1	1	1	1

ZEUS 2

VERGLASUNG TÜR

BITTE BEACHTEN SIE...

In diesem Aufbausritt sollten Sie mit 2-3 Personen arbeiten. Beim Einsetzen der Verglasung bitte Schutzhandschuhe, Schutzbrille, Sicherheitsschuhe und Kopfschutz tragen! Beachten Sie die vorgegebene Reihenfolge der Verglasung (7a-7b-7c). Bei den Hohlkammerplatten ist die Außenseite mit einer Folie und/oder einer seitlichen Kennzeichnung versehen.

Für 4 mm Glas wird die Glasdichtung 6090 benötigt. Bei Hohlkammerplattenverglasung wird diese nicht benötigt. Abstandshalter 7406 – 7409 werden für Glas oder 16 mm Hohlkammerplatten nicht benötigt.

Wenn Sie sich für die Variante mit 4 mm ESG-Glas entschieden haben, drücken Sie die Glasdichtung 6090 auf die Aluminiumprofile (7c.2) und schneiden Sie sie auf Länge. Durch Einführen der Schrauben 7058 in verschiedene Führungsschienen der Abdeckkappen ist es möglich, die Türen mit 4 mm, 6 mm, 10 mm oder 16 mm starken Scheiben zu verglasen (7c.2). Führen Sie die Schrauben 7058 in die Abdeckkappen, wie in (7c.3) gezeigt. Legen Sie die Scheiben auf den Aluminium-Rahmen. Stecken Sie die Abdeckkappen auf und verschrauben Sie sie lose mit den Schrauben 7053. Prüfen Sie, ob die Tür rechtwinklig ist, bevor sie alle Schrauben anziehen. Bitte nicht zu fest anziehen.

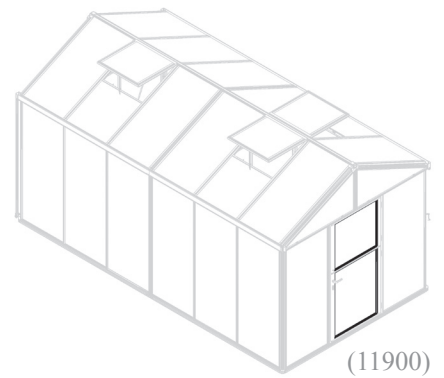

(11900)

Verglasung Tür

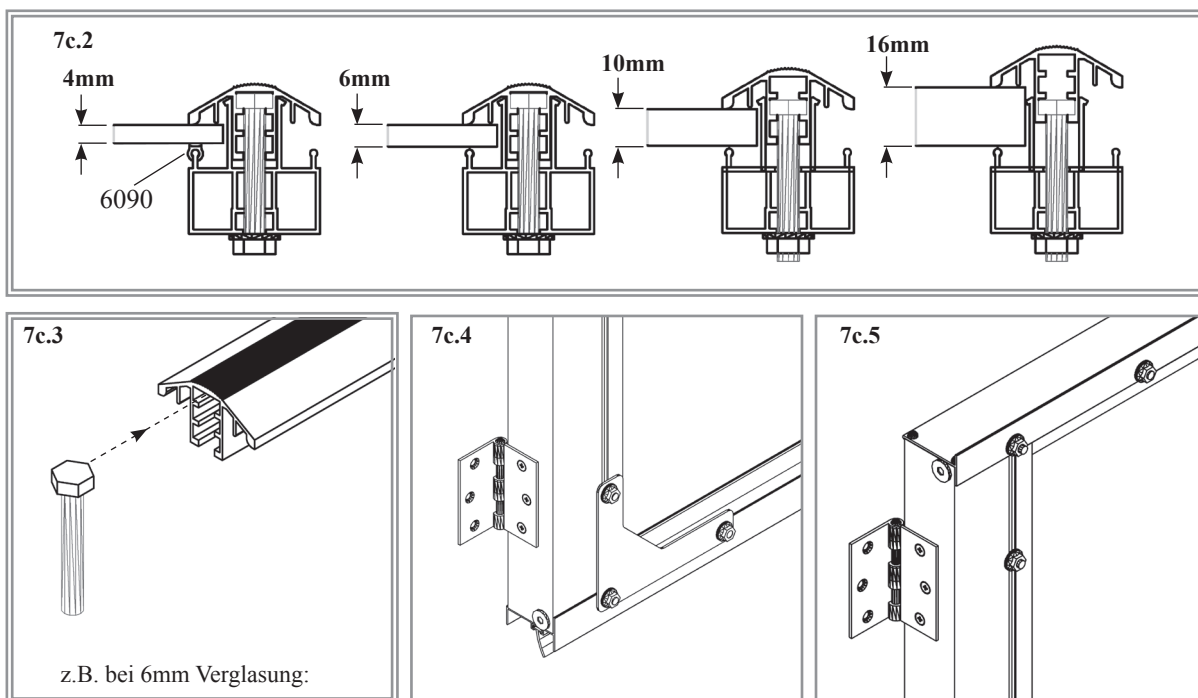

ZEUS 2

(10000)

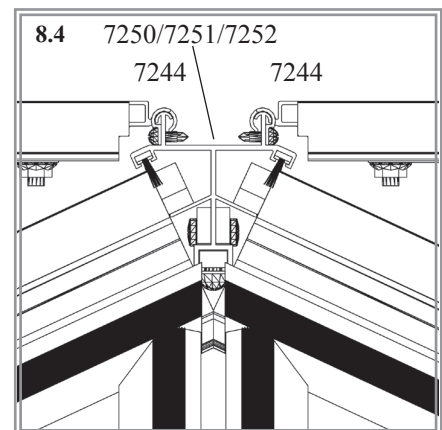
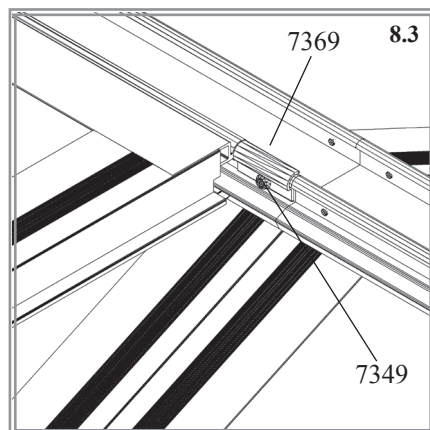
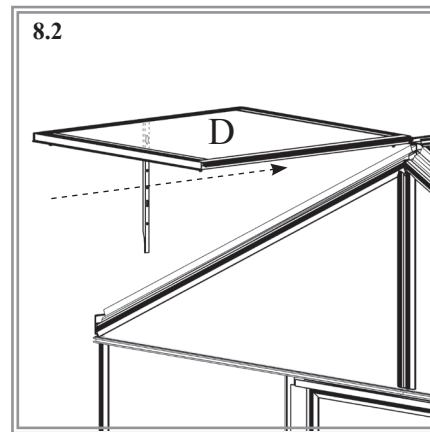
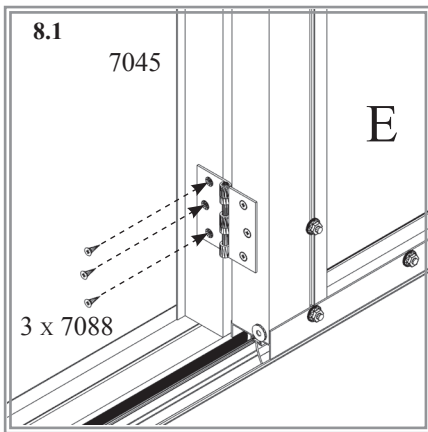
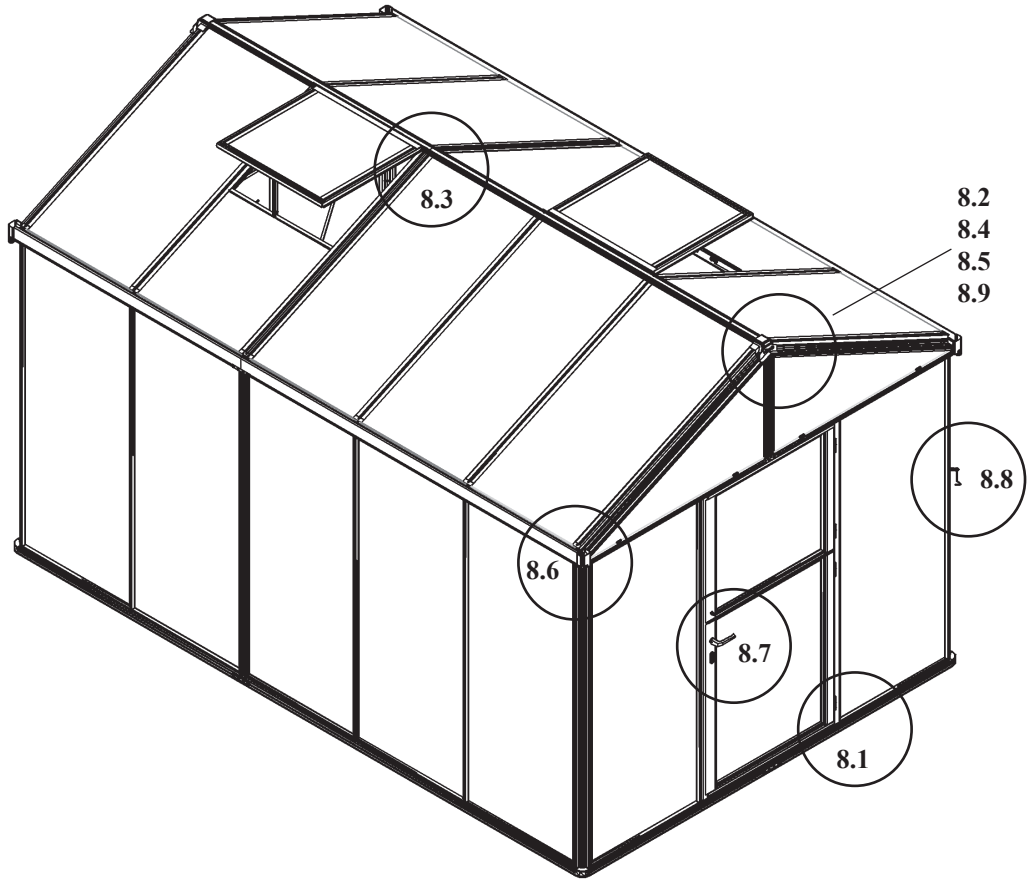

Modell				
8100	10000	11900	13800	15700
7053				
1	1	1	1	1
7056				
4	4	4	4	4
7088				
12	12	12	12	12
7111				
1	1	1	1	1
7112				
1	1	1	1	1
7113				
1	1	1	1	1
7266				
2	2	2	2	2
7349				
4	4	6	6	6
7369				
4	4	6	6	6
7370				
2	2	2	2	2
7371				
2	2	2	2	2
7399				
1	1	1	1	1

ABSCHLUSSARBEITEN

BITTE BEACHTEN SIE...

Überprüfen Sie, ob das Gewächshaus absolut rechtwinklig ist und alle Schrauben und Muttern fest sitzen. Bitte die Schrauben nicht zu fest anziehen. Kontrollieren Sie nach 14 Tagen den festen Sitz der Muttern.

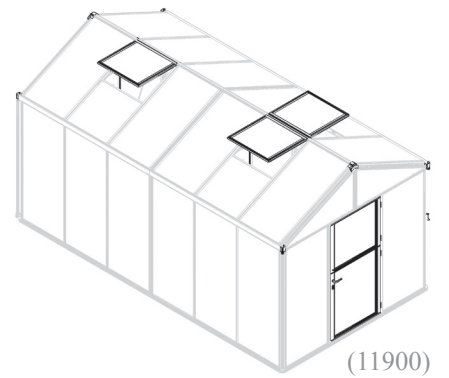

Befestigen Sie die in Schritt 6 montierten Türen am Türrahmen 7045 mit den Schrauben 7088 (8.1). Schieben Sie die Fenster von der Front-/Rückseite in das Firstprofil (8.2). Montieren Sie den Dachfensterfeststeller 7369 mit den selbstschneidenden Schrauben 7349 auf beiden Seiten des Dachfensters (8.3)(8.4).

Schieben Sie die Firstabdeckkappe 7266 auf beide Firstenden und befestigen Sie diese mit 2 selbstschneidenden Schrauben 7056 (8.5). Schieben Sie die Kunststoffecken 7370 und 7371 auf die Traufenprofile 7213, 7214 oder 7215 (8.6). *☞ Es kann helfen, das Traufenprofil 7213, 7214 oder 7215 an der Oberkante zu ziehen, vorsichtig weg vom Haus, so dass die Öffnung für den Kunststoff grösser wird.* Montieren Sie den Türfeststeller 7111 mit dem Abstandshalter 7112 auf dem oberen horizontalen Türprofil 7018 (8.7). Führen Sie die Schraube 7399 in den Schraubenkanal des Eckprofils 7236. Justieren Sie die Höhe entsprechend zum Türfeststeller 7111 und fixieren Sie mit Mutter 7053. Montieren Sie den Riegel 7113 mit Schraube 7399 (8.8).



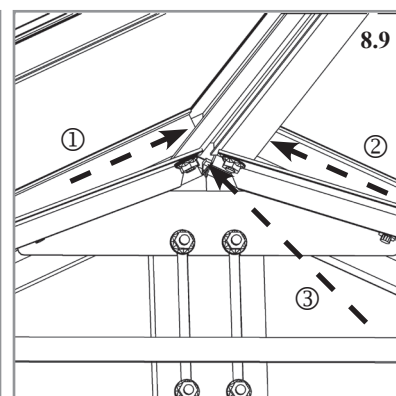
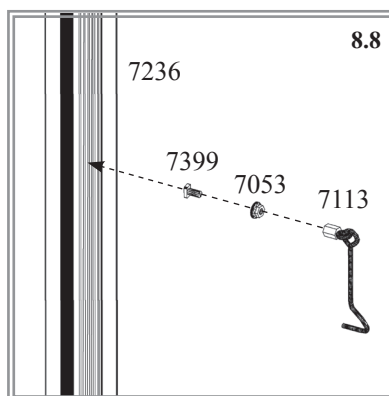
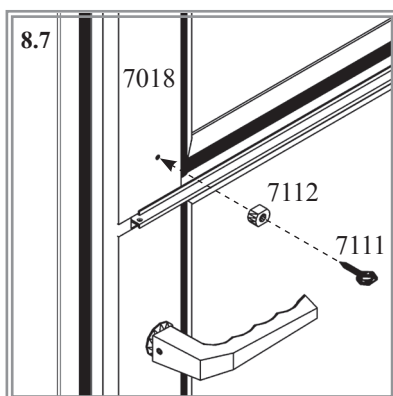
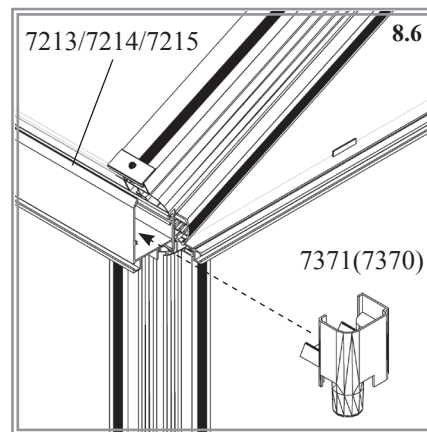
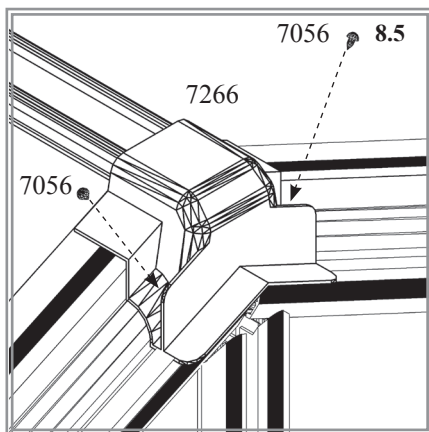





Es wird empfohlen, **neutral-vernetzendes** Silikon zu benutzen: von außen entlang der Firstverbindung und von innen zum Füllen der Firstecken an 3 Punkten (8.9). Neutral-vernetzendes Silikon gehört nicht zum Lieferumfang. Montieren Sie die Schwellenwinkel 7095 mit Schrauben und Bolzen (nicht mitgeliefert) am Untergrund. Kennzeichnen Sie das Haus von innen mit dem beiliegenden Typenaufkleber. Falls Sie später einmal ein Ersatzteil benötigen, teilen Sie bitte diese Typenbezeichnung Ihrem Kundendienst mit.



Abschlussarbeiten

ZEUS 2

Alle Modelle

1002 x2	
1006 x2	
1402 x2	
1403 x2	
1405 x2	
1409 x2	
1412 x2	
1415 x2	

(11900)

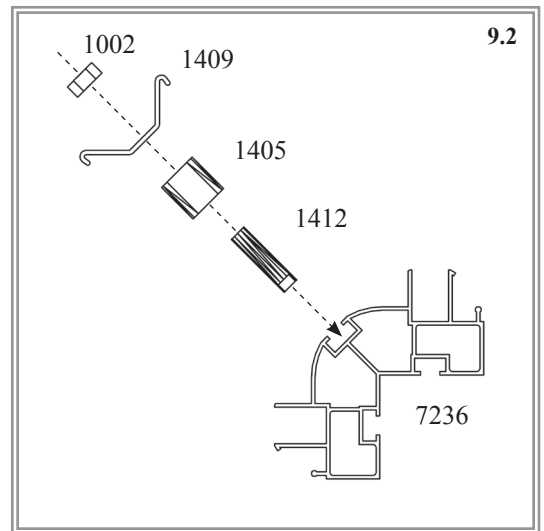
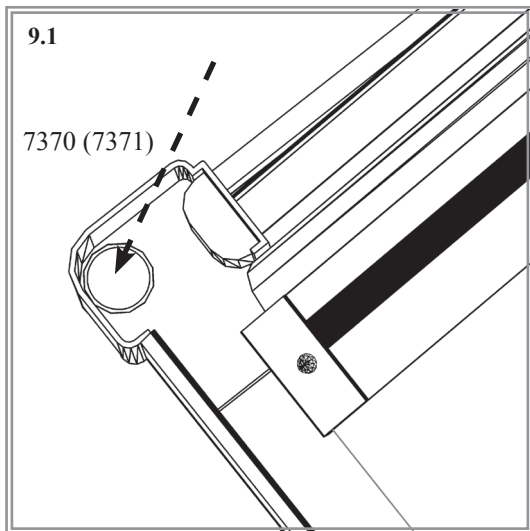
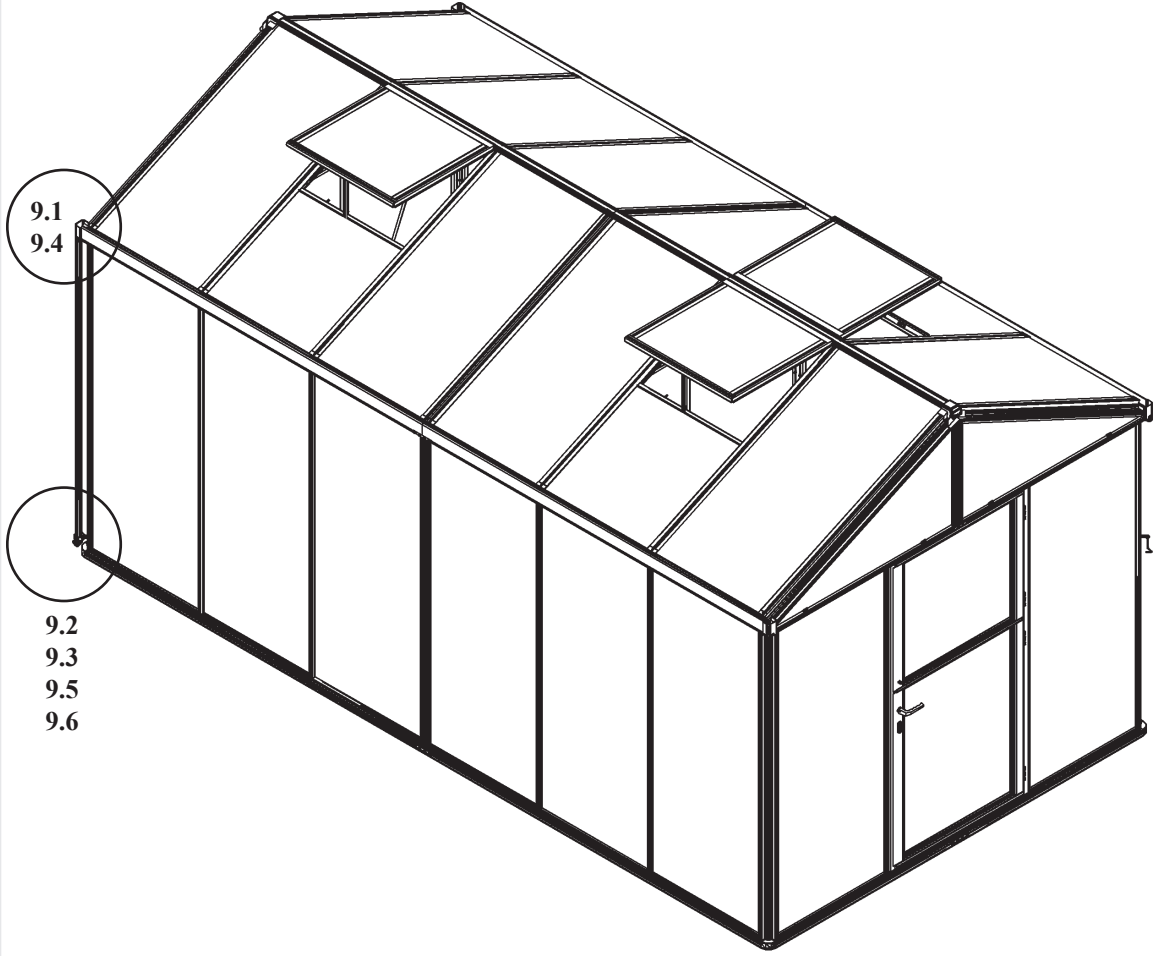

REGENFALLROHRE

BITTE BEACHTEN SIE...

Bitte Schutzhandschuhe und Schutzbrille tragen!

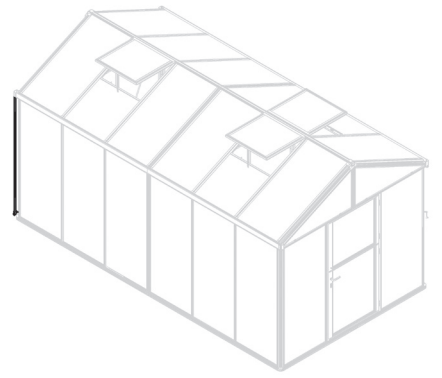

Nehmen Sie bitte einen Bohrer mit nicht mehr als 25 mm Durchmesser und bohren Sie ein Loch in dem markierten Bereich an der Innenseite der Teile 7370 oder 7371 (9.1). Führen Sie eine Schraube 1412 in den Schraubenkanal am unteren Eckpfosten 7236 und montieren Sie die Teile 1405 und 1409 mit den Muttern 1002 an beiden Seiten (9.2). Bringen Sie den Ellbogen 1402 am unteren Regenfallrohr 1415 (9.3) an und montieren Sie es dann an der Plastiktraufe 7370 oder 7371 (9.4). Bringen Sie die Fallrohrklemme 1403 um das Fallrohr herum an und verbinden Sie sie mit 1409 (9.5). Führen Sie die Schraube 1006 ein um das Fallrohr zu fixieren (9.6).

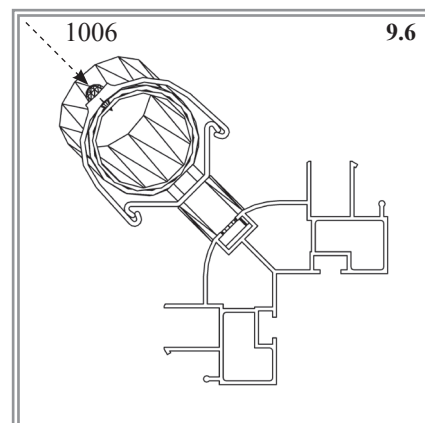
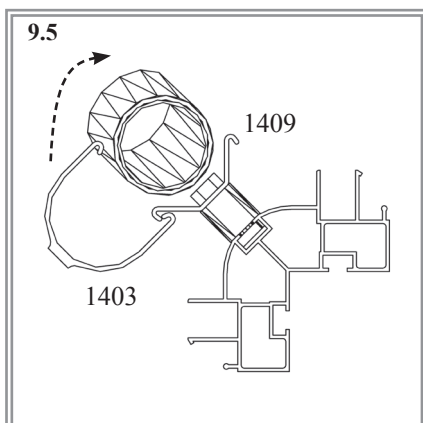
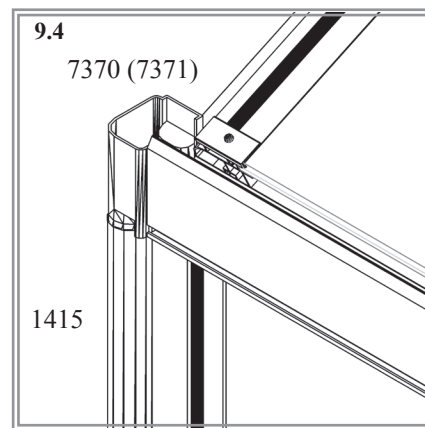
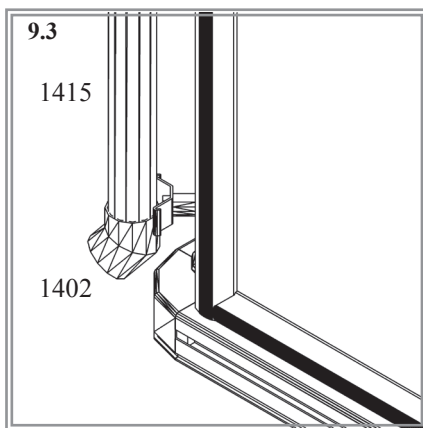

Regenfallrohre

ZEUS 2



E.P.H. Schmidt u. Co. GmbH
Hoefkerstrasse 30
44149 Dortmund
Postfach 170163
44060 Dortmund
Deutschland
Tel.: +49 231 941655 0
Fax: +49 231 941655 99
www.eph-schmidt.de
verkauf@eph-schmidt.de

OPJ A/S
Volderslevvej 36 A
Postboks 480
5260 Odense S
Danmark
Tel.: +45 66 15 10 30
Fax: +45 66 15 00 84
www.opj.dk
opj@opj.dk